

Physics

Student's Book

**For Associate Nursing
Program**



© 2022 Rwanda Basic Education Board
All rights reserved

This book is property of the Government of Rwanda. Credit must be given to
REB when the content is quoted

FOREWORD

Dear Student,

Rwanda Basic Education Board is honored to present to you this Physics Book for Senior five which serves as a guide to competence-based teaching and learning to ensure consistency and coherence in the learning of physics subject. The Rwandan educational philosophy is to ensure that you achieve full potential at every level of education which will prepare you to be well integrated in society and exploit employment opportunities.

The government of Rwanda emphasizes the importance of aligning teaching and learning materials with the syllabus to facilitate your learning process. Many factors influence what you learn, how well you learn and the competences you acquire. Those factors include the instructional materials available among others. Special attention was paid to the activities that facilitate the learning process in which you can develop your ideas and make new discoveries during concrete activities carried out individually or with peers.

In competence-based curriculum, learning is considered as a process of active building and developing knowledge and meanings by the learner where concepts are mainly introduced by an activity, a situation or a scenario that helps the learner to construct knowledge, develop skills and acquire positive attitudes and values.

- For effective use of this textbook, your role is to:
- Work on given activities which lead to the development of skills
- Share relevant information with other learners through presentations, discussions, group work and other active learning techniques such as role play, case studies, investigation and research in the library, from the internet or from your community;
- Participate and take responsibility for your own learning;
- Draw conclusions based on the findings from the learning activities.

I wish to sincerely extend my appreciation to REB staff who organized the editing process of this book. Special gratitude goes to the lecturers, teachers, illustrators and designers who diligently worked to successful completion of this book. Any comment or contribution would be welcome for the improvement of this textbook for the next edition.

Dr. Nelson MBARUSHIMANA

Director General, REB

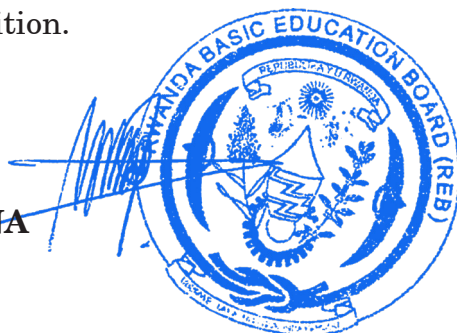

ACKNOWLEDGEMENT

I wish to express my appreciation to all the people who played a major role in editing process of Physics book for senior five. It would not have been successful without their active participation.

Special thanks are given to those who gave their time to read and refine this textbook to meet the needs of competence-based curriculum. I owe gratitude to different Universities and schools in Rwanda that allowed their staff to work with REB to edit this book. I therefore, wish to extend my sincere gratitude to lecturers, teachers, illustrators, designers and all other individuals whose efforts in one way or the other contributed to the success of this edition.

Finally, my word of gratitude goes to the Rwanda Education Board staff particularly those from Curriculum, Teaching and Learning Resources Department who were involved in the whole process of editorial work.



Joan MURUNGI,

Head of Department of Curriculum, Teaching and Learning Resources

TABLE OF CONTENTS

FOREWORD	3
-----------------------	----------

ACKNOWLEDGEMENT.....	4
-----------------------------	----------

UNIT1: WAVE AND PARTICLE NATURE OF LIGHT .. 1

1.0. Introduction.....	2
------------------------	---

1.1. Nature and properties of light.....	3
--	---

1.2. Photon theory of light and photoelectric effect	9
--	---

1.3. Properties of a light wave	11
---------------------------------------	----

1.4. Blackbody radiation.....	13
-------------------------------	----

1.5. Energy, mass and momentum of a photon	17
--	----

1.6. Compton effect and Photon interactions.....	19
--	----

1.7. The wave nature of matter	21
--------------------------------------	----

UNIT2: SIMPLE HARMONIC MOTION29

2.0. Introduction.....	30
------------------------	----

2.1. Kinematics of Simple Harmonic Motion	31
---	----

2.2. Simple Harmonic oscillators.....	40
---------------------------------------	----

2.3. Kinetic and Potential energy of an oscillating system.....	49
---	----

2.4 Energy changes and Energy conservation in an oscillating system.....	50
--	----

2.5. superposition of harmonics of same frequency and same direction	53
--	----

UNIT3: FORCED OSCILLATIONS AND RESONANCE OF A SYSTEM59

3.0. Introduction	60
-------------------------	----

3.1. Damped oscillations.	61
--------------------------------	----

3.2. Equation of Damped oscillations.....	62
---	----

3.3. The solution of equation of damping.....	63
---	----

3.4. TypeS of damped oscillation.....	65
---------------------------------------	----

3.5. Natural frequency of a vibration and forced oscillation.	71
3.6. Equation of forced oscillation and its solution.....	72
3.7. Variation of forced frequency on graph At amplitude close to natural frequency of vibration.	75
3.8. Resonance	75
3.9. Applications and examples of resonance in everyday life.....	77
3.10. effect of resonance on a system	80

UNIT4: PROPAGATION OF MECHANICAL WAVES83

4.0. Introduction.....	84
4.1. The concept of waves.....	84
4.2. Terms used and characteristics of waves.....	85
4.3. Types of waves	89
4.4. Progressive waves	94
4.5. Principle of superposition	97
4.6. Properties of waves	99
4.7. Wave on a vibrating string	104

UNIT 5:INTERFERENCE OF LIGHT WAVES115

5.0. Introduction.....	116
5.1. Nature of electromagnetic waves	116
5.2. Conditions for interference with two sources of light.....	122
5.3. Principle of superposition	122
5.4. Interference pattern of two coherent point sources of light.....	125
5.5. Young's Double-slit experiment.....	125

5.6. Intensity distribution of fringe pattern.....129

UNIT 6: COMPLEX ELECTRICAL CIRCUIT.....135

6.0. Introduction.....136

6.1. Kirchhoff's Laws.....138

6.2. Design of complex and simple electric circuits142

6.3. Resistors and electromotive forces in series and parallel complex circuits145

6.4. Simple potentiometer circuits148

6.5. Measurement of current by Potentiometer.....155

6.6. Advantages and disadvantages of potentiometer.....159

UNIT 7: ELECTRIC FIELD AND GRAVITATIONAL POTENTIAL.....164

7.0 Introduction165

7.1 Electric potential.....165

7.2 Electrodynamics179

7.3 Gravitational energy.....185

UNIT 8: MOTION IN ORBITS199

8.1. Introduction.....200

8.2. Newton's law of gravitation.....201

8.3. Kepler's laws of planetary motion.....202

8.4..Verification of Kepler's third law of planetary motion204

8.5..Acceleration due to gravity at the surface of the earth210

8.6..Variation of acceleration due to gravity with height212

8.7. Variation of gravity with depth.....214

8.8. Variation in g Due to Rotation of Earth216

8.9. Variation of 'g' Due to Shape of Earth	219
8.10. Rocket	219
8.11. Satellites.....	221
8.12 Types and applications of Satellite Systems	230
8.13. Cosmic velocity first, second and third.....	233

UNIT 9: ATOMIC MODELS AND PHOTOELECTRIC EFFECT.....243

9.0. Introduction.....	244
9.1. Structure of the Atom and Thomson's Model.....	245
9.2. Rutherford's atomic model	248
9.3. Bohr's atomic model.....	250
9.4. Energy levels and spectral lines of Hydrogen	252
9.5. Thermionic emission (thermo electronic emission)	253
9.6. Applications of cathode rays.....	254
9.7. Fluorescence and phosphorescence	257
9.8. Photoelectric emission laws	258
9.9. Photoelectric effect	259
9.10. Factors affecting photoelectric emission.....	260
9.11. Photon, work function and Planck's constant	261
9.12. Einstein's equation	262
9.13. Application of photoelectric effect	267
... (photo emissive and photovoltaic cells).....	267
9.14 Compton effect.....	268

UNIT 10: ANALOG AND DIGITAL SIGNALS274

10.1. Introduction.....	275
10.2. Information transmission in a communication system	276
10.3. Communication Terms and Concepts	277
10.4. Elements of communication.....	278
10.5. Types of information and requirements.....	280
10.6. Simplex transmission.....	281
10.7. Half-duplex communications	281
10.8. Full-duplex communications	282
10.9. Bandwidth and signal Frequency	283
10.10. Analog signal system	283
10.11. Analog signals	285
10.12. Advantages and disadvantages of analog signals	285
10.13. Digital signals	285
10.14. Advantages of digital technology	286
10.15. Comparing digital and analog signals	287
10.16. Logic gates	290

UNIT 11: MOBILE PHONE AND RADIO COMMUNICATION.....297

11.0. Introduction	298
11.1. Concepts of transmission system	299
11.2. Principle of cellular radio	301
11.3. Structure of cellular network	301

11.4. Principle of cellular network	302
11.5. Mobile communication systems.....	306
11.6. radio transmission (Am, fm, pm).....	308
11.7. Post, telegraph and telephone (PTT).....	311

**UNIT 12: RELATIVITY CONCEPTS AND POSTULATES
OF SPECIAL RELATIVITY315**

12.0. Introduction.....	316
12.1. Definition of relativity	316
12.2. Concept of space, time and mass.....	316
12.3. Concept of Frame of reference	322
12.4. Galilean equation of transformation	323
12.5. Postulates of special theory of relativity.....	326
12.6. Concept of simultaneity	326
BIBLIOGRAPHY	329

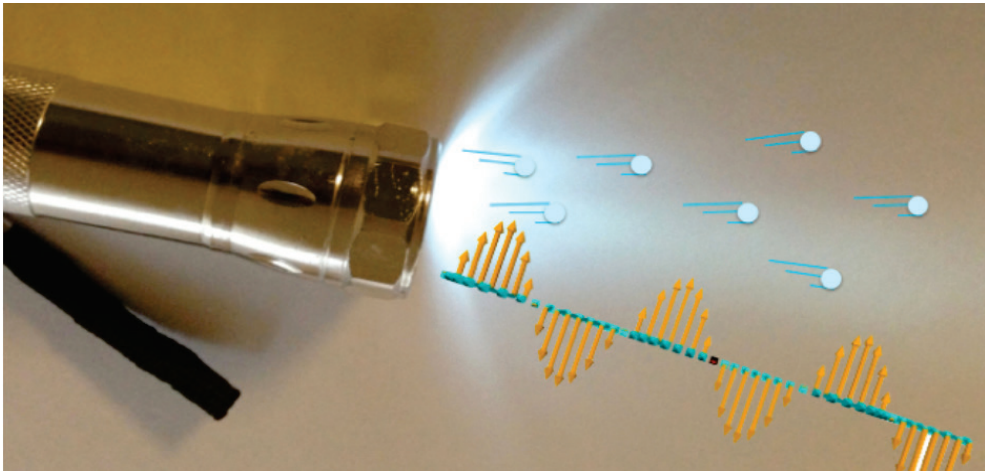
UNIT
1WAVE AND PARTICLE
NATURE OF LIGHT

Key unit competence: Analyze the nature of light.

Unit Objectives:

By the end of this unit I will be able to;

- ◇ Explain the Planck's quantum theory and apply it to other theories.
- ◇ Explain photoelectric effect and use it to derive and apply Einstein's photoelectric equation
- ◇ explain photoelectric effect and use it to derive and apply Einstein's photoelectric equation.
- ◇ Explain the wave theory of light and state its limitations.
- ◇ Evaluate properties of light as a wave.
- ◇ Differentiate electron microscope and Compton Effect as applied in medicine.

1.0 INTRODUCTION

Until the late 19th century physicists used to explain the phenomena in the physical world around them using theories such as mechanics, electromagnetism, thermodynamics and statistical physics that are known as classical theories.

At the turn of the 19th century, more and more experiments showed effects that could not be explained by these classical theories. This indicated a need for a new theory that we now know as *quantum mechanics*. Quantum mechanics is the system of laws which governs the behaviour of matter on the atomic scale. It is the most successful theory in the history of science, having withstood thousands of experimental tests without a single verifiable exception. So, the quantum mechanics is required to analyze the behaviour of photons, electrons and other particles that make up the universe.

This theory is the most useful in various studies especially for Radiography and Physiotherapy in Medicine, electrons and photons in Chemistry and Astronomy in Geography.

Introductory Activity

Clearly observe the image shown on Fig.1-1, with kids playing on a slide with the help of their father Mr. John and answer the questions that follow.



Fig. 1-1; Kids playing on the slide

- Sarah is climbing the ladder. How do you think her potential energy is changing?
- Comment on the potential energies of Jovia and Peter.
- How is the change in the potential energy of Jovia as she slides down?

What do you think is Mr. John doing on the young kid? Give your comments.

Fig.1.2 below shows how light interacts with an electron. F and B are the terminals of the circuit (the wires of an external circuit).

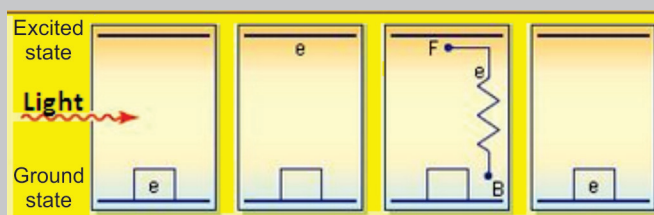

Fig.1.2: Interaction of light and electron

The working mechanism of Fig.1.2 is used in solar cells and solar panels. Clearly analyse Fig.1.2 and compare it with the situation on Fig.1.1, take children as electrons at different points or positions, and make your comments.

1.1 NATURE AND PROPERTIES OF LIGHT

1.1.1 Particle theory of light

The nature and properties of light has been a subject of great interest and speculation since ancient times. Until the time of **Isaac Newton** (1642–1727), the **Greeks** believed that *light consisted of tiny particles (corpuscles) that either were emitted by a light source or emanated from the eyes of the viewer.*

Newton the chief architect of the particle theory of light held that light consisted of *tiny particles that were emitted from a light source and that these particles stimulated the sense of sight upon entering the eye.* Using this idea (particle theory), he was able to explain reflection and refraction (bending) of light.

However, his derivation of the law of refraction depend on the assumption that light travels faster in water and in glass than in air, an assumption later shown to be false.

Most scientists accepted Newton's particle theory.

1.1.2 Wave theory and Planck's quantum theory of light.

Does light exhibit diffraction? In the mid-seventeenth century, the Jesuit priest **Francesco Grimaldi** (1618–1663) had observed that when sunlight entered a darkened room through a tiny hole in a screen, the spot on the opposite wall was larger than would be expected from geometric rays. He also observed that the border of the image was not clear but was surrounded by colored fringes. Grimaldi attributed this to the diffraction of light.

In 1678, one of Newton's contemporaries, the Dutch physicist and astronomer Christian **Huygens (1629–1695)**, was able to explain many other properties of light by proposing that light is a **wave**.

According to the Huygens' wave theory:

- Light travels in the form of longitudinal waves which travel with uniform velocity in homogeneous medium.
- Different colours are due to the different wavelengths of light waves.
- We get the sensation of light when these waves enter our eyes.
- In order to explain the propagation of waves of light through vacuum, Huygens suggested the existence of a hypothetical medium called luminiferous ether, which is present in vacuum as well as in all material objects. Since ether couldn't be detected, it was attributed properties like:
 - It is continuous and is made up of elastic particles.
 - It has zero density.
 - It is perfectly transparent.
 - It is present everywhere

Using his wave theory of light, Huygens was able to explain reflection and refraction of light by assuming that light travels more slowly in water and in glass than in air.

Huygens' Principle is particularly useful for analyzing what happens when waves run into an obstacle. The bending of waves behind obstacles into the "shadow region" is known as **diffraction**. Since diffraction occurs for waves, but not for particles, it can serve as one means for distinguishing the nature of light.

The Huygens' Principle of the wave theory of light states that: “*Every point on a wavefront may be considered a source of secondary spherical wavelets which spread out in the forward direction at the speed of light. The new wavefront is the tangential surface to all of these secondary wavelets.*”

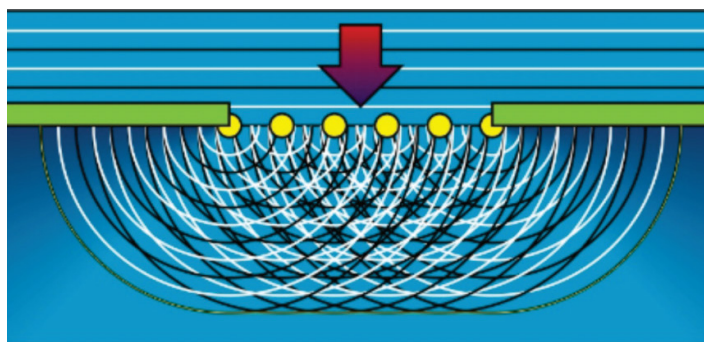

Fig.1. 3 Diffraction of a plane wave of a slit whose width is several times the wavelength

In 1801, the Englishman Thomas **Young** (1773–1829) provided the first clear demonstration of the wave nature of light and showed that light beams can **interfere** with one another, giving strong support to the wave theory. Young showed that, under appropriate conditions, light rays interfere with each other. Such behavior could not be explained at that time by a particle theory because there was no conceivable way in which two or more particles could come together and cancel one another.

The general acceptance of wave theory was due to the French physicist **Augustin Fresnell** (1788-1827), who performed extensive experiments on interference and diffraction and put the wave theory on a mathematical basis. In 1850, **Jean Foucault** measured the speed of light in water and showed that it is less than in air, thus ruling out Newton's particle theory.

However, in 1900, German Physicist **Max Planck** (1858–1947) returned to the particle theory of light to explain the thermal radiation emitted by hot objects. To explain these radiations, Max Planck put forward a theory known as **Planck's quantum theory** suggests that:

1. The matter is composed of a large number of oscillating particles. These oscillators have different frequencies.
2. The radiant energy which is emitted or absorbed by the blackbody is not continuous but discontinuous in the form of small discrete packets of energy and each such packet of energy is called a 'quantum'. In case of light, the quantum of energy is called a 'photon'.

3. The energy of each quantum is directly proportional to the frequency (f) of the radiation, i.e.

(Let ' E ' be the energy and ' f ' be the frequency)

Then, $E \propto f$ or $E = hf$ Equation 1.1

$$E = \frac{hc}{\lambda}; \left(f = \frac{c}{\lambda} \right) \quad \text{..... Equation 1.2}$$

whereas c is the speed of light, λ is the wavelength and h is the Planck's constant ($h = 6.63 \times 10^{-34}$ J.s.).

4. The oscillator emits energy, when it moves from one quantized state to the other quantized state. The oscillator does not emit energy as long as it remains in one energy state. The total amount of energy emitted or absorbed by a body will be some whole number quanta. Hence,

$$E = nhf = \frac{nhc}{\lambda} \quad \text{..... Equation 1.3}$$

where n is an integer.

According to the Planck's theory, the exchange of energy between quantized states is not continuous but discrete. This quantized energy is in small packets of bundles. The bundle of energy or the packet of energy is called quantum (plural quanta).

1.1.3 Wave particle duality of light

Today, scientists view light as having a dual nature—that is, light exhibits characteristics of a wave in some situations and characteristics of a particle in other situations.

Although the wave model and the classical theory of electromagnetism were able to explain most known properties of light, they could not explain some subsequent experiments. The most striking of these is the photoelectric effect, also discovered by **Hertz**: When light strikes a metal surface, electrons are sometimes ejected from the surface. As one example of the difficulties that arose, experiments showed that the kinetic energy of an ejected electron is independent of the light intensity. This finding contradicted the wave theory, which held that a more intense beam of light should add more energy to the electron.

In view of these developments, light must be regarded as having a dual nature: Wave-particle duality postulates that all particles exhibit both **wave properties** and particle properties.

- Phenomena of light like interference, diffraction and polarization can

be explained by wave theory and not by particle nature of light.

- Energy distribution in perfect blackbody radiation, photo electric effect and Compton Effect can be explained by particle nature of light and not by wave theory. The concept of quantum mechanics is applied even to the motion of electrons in an atom in Bohr's atomic model.

If light waves can behave like particles, can the particles of matter behave like waves? As we will discover, the answer is a resounding yes. Electrons can be made to interfere and diffract just like other kinds of waves. Light is light, to be sure. However, the question "Is light a wave or a particle?" is inappropriate. Sometimes light acts like a wave, and at other times it acts like a particle.

1.1.4 The principle of complementarities

The principle of complementarities refers to the effects such as wave particle duality in which different measurements made on the system reveal it to have either particle-like or wave-like properties. Both properties are necessary to gain the complete knowledge of the phenomena; they are complementary to each other; but at the same time, they also exclude each other.

Within the scope of classical physics, all characteristic properties of a given object can be ascertained by a single experimental arrangement, although in practice various arrangements are often convenient for the study of different aspects of the phenomena. In fact, data obtained in such a way simply supplement each other and can be combined into a consistent picture of the behaviour of the object under investigation. In quantum physics, however, evidence about atomic objects obtained by different experimental arrangements exhibits a novel kind of complementary relationship.

EXAMPLE 1.1

The laser in a compact disc player. It uses light with a wavelength of 7.8×10^2 nm. Calculate the energy of a single photon of this light.

Solution:

From Equation 1.2,

$$\begin{aligned} E &= \frac{hc}{\lambda} && \text{(Speed of light = } 3 \times 10^8 \text{ m/s)} \\ &= \frac{6.63 \times 10^{-34} \times 3 \times 10^8}{7.8 \times 10^2 \times 10^{-9}} && \text{(1 nm = } 10^{-9} \text{ m)} \\ E &= 2.55 \times 10^{-19} \text{ J} \end{aligned}$$

EXAMPLE 1.2

What is the ratio between the energies of two radiations, one with a wavelength of 200 nm and the other with 600 nm?

Solution:

Let us use $\lambda_1 = 200 \text{ nm}$ and $\lambda_2 = 600 \text{ nm}$

$$E_1 = \frac{hc}{\lambda_1} = \frac{(6.63 \times 10^{-34} \text{ J} \cdot \text{s})(3 \times 10^8 \text{ m/s})}{200 \times 10^{-9} \text{ m}} = 9.95 \times 10^{-19} \text{ J}$$

$$E_2 = \frac{hc}{\lambda_2} = \frac{(6.63 \times 10^{-34} \text{ J} \cdot \text{s})(3 \times 10^8 \text{ m/s})}{600 \times 10^{-9} \text{ m}} = 3.32 \times 10^{-19} \text{ J}$$

$$\therefore \text{The ratio of } E_1 \text{ to } E_2 \text{ is } \frac{E_1}{E_2} = \frac{9.95 \times 10^{-19} \text{ J}}{3.32 \times 10^{-19} \text{ J}} = 3$$

Hence, $E_1 : E_2 = 3 : 1$

Or the ratio of two is

$$\frac{E_1}{E_2} = \frac{\frac{hc}{\lambda_1}}{\frac{hc}{\lambda_2}} = \frac{\lambda_2}{\lambda_1} = \frac{600}{200} = 3$$

The energy is inversely proportional to the wavelength.

Application Activity 1.1

- Which of the following can be thought of as either a wave or a particle?
 - A. Light.
 - B. An electron.
 - C. A proton.
 - D. All of the above.
- Electrons and photons of light are similar in that
 - Both have momentum given by
 - Both exhibit wave-particle duality.
 - Both are used in diffraction experiments to explore structure.
 - All of the above
 - None of the above
- What is quantum mechanics?
- What is Planck's quantum theory?
- Explain Planck's hypothesis or what are the postulates of Planck's quantum theory?

6. A laser emits light energy in short pulses with frequency 4.69×10^{14} Hz and deposits 1.3×10^{-2} J for each pulse. How many quanta of energy does each pulse deposit?
7. A laser pointer with a power output of 5.00 mW emits red light
 - a. What is the magnitude of the momentum of each photon?
 - b. How many photons does the laser pointer emit each second?
8. a. Light of a certain orange colour has a wavelength of 589 nm. What is the energy of one photon of this light? Speed of light $c = 3.00 \times 10^8$ m/s .
 - b. Show that the photons in a 1240 nm infrared light beam have energies of 1.00 eV.

1.2 PHOTON THEORY OF LIGHT AND PHOTOELECTRIC EFFECT

Before Einstein, photoelectric effect had been observed by scientists, but they were confused by the behavior because they didn't fully understand the nature of light. In the late 1800s, **physicists James Clerk Maxwell** in Scotland and **Hendrik Lorentz** in the Netherlands determined that light appear to behave as a wave. This was proven by seeing how light waves demonstrate interference, diffraction and scattering, which are common to all sorts of waves (including waves in water.)

So Einstein's argument in 1905 that light can also behave as a set of particles was revolutionary because it did not fit with the classical theory of electromagnetic radiation. Other scientists had postulated the theory before him, but Einstein was the first to fully elaborate on why the phenomenon occurred – and the implications'. Einstein was awarded the Nobel Prize in 1921 for his discovery of the law of the photoelectric effect.

For example, a German physicist **Heinrich Rudolf Hertz** was the first person to see the photoelectric effect, in 1887. He discovered that if he shone ultraviolet light onto metal electrodes, he lowered the voltage needed to make a spark move behind the electrodes, according to English astronomer David Darling. In 1888 **Hallwachs** discovered that an insulated zinc plate, negatively charged, lost its charge if exposed to ultraviolet light. So light gives energy to the electrons in the surface atoms of the metal, and enables them to break through the surface. This called the photoelectric effect.

Photoelectric effect is the emission of electrons from the surface of metal when illuminated with electromagnetic radiation of sufficient frequency.

This effect is mainly observed when charged surfaces are illuminated with ultraviolet radiation. However, visible light can also cause photoelectric effect on surfaces like cesium oxide. A material that exhibits photoelectric effect is said to be **Photosensitive**.

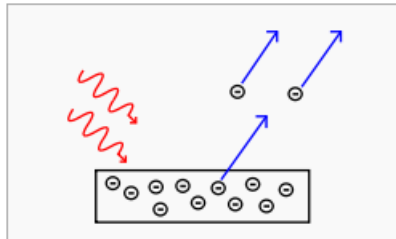

Fig.1. 4 Incoming photons on the left strike a metal plate (bottom), and eject electrons, each with energy $E = hf$ depicted as flying off to the right.

An evacuated tube known as **photocell** contains a metal plate P connected to a negative terminal of variable power supply and a smaller electrode C connected at positive of variable power supply. The two electrodes are connected to an ammeter and a source of emf, as shown in Fig.1.5.

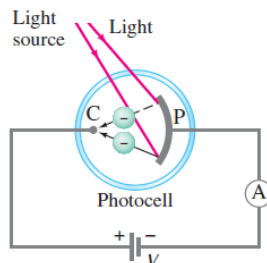

Fig.1.5: Wavelength of a Sinusoidal wave

When the photocell is in the dark, the ammeter reads zero. But when light of sufficiently high frequency illuminates the plate, the ammeter indicates a current flowing in the circuit across the gap between P and C. This effect is called the **photoelectric effect** and it occurs in many materials, but is most easily observed with metals.

We explain completion of the circuit by imagining that electrons, ejected from the plate by the impinging light, flow across the tube from the plate P to a positive electrode called the “collector” C and cause a current to register on the ammeter A as indicated in Fig. 1.5.

Photocurrent is the current that flows through a photosensitive device, such as a photodiode, as the result of exposure to radiant power. The photo current may occur as a result of the photoelectric, photo emissive or photo-voltaic effect.

1.3 PROPERTIES OF A LIGHT WAVE

The properties of waves include the following:

The **wavelength** of a wave is defined as the distance over which the wave's shape repeats.

It is the distance between the corresponding points on successive cycles, eg. the distance between two wave crests is known as wavelength of a sinusoidal wave. It is measured in units of length (metres, nanometres). The wavelength is usually represented by the symbol λ (lambda).

A measurement of the wavelength is made by observing the wave in space at a single instant of time.

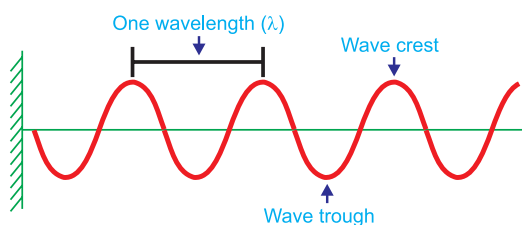

Fig.1.6: Wavelength of a Sinusoidal wave

Amplitude: The maximum displacement of wave quantity relative to the undisturbed, equilibrium position of a particle is called amplitude. for example, height of water wave, pressure of sound wave, maximum electric field, etc.

Periodic time: This is the time between two successive wave crests or successive wave troughs. It is measured in units of time (second). The period is often represented by the letter T. It is measured by observing the wave displacement at a single point in space.

Frequency: The number of cycles per second of the wave quantity, measured in hertz (Hz) is called frequency. The frequency is usually represented by the letter f . The observation of the frequency is made at a single point in space.

Mathematically;

$$f = \frac{1}{T} \quad \text{..... Equation 1.4}$$

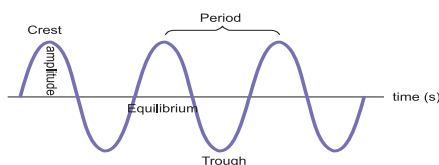

Fig.1.7: Period and amplitude of the wave

Phase angle: The number of units of angular measure between a point on the wave and a reference point in a periodic wave is called phase angle.

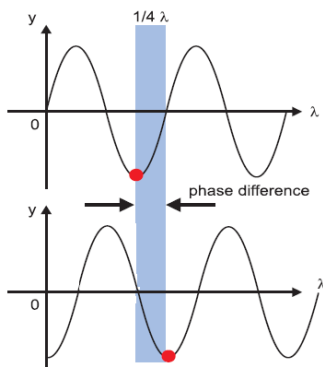

Fig.1.8: Phase angle of the wave

The phase angle at any point is calculated using simple proportions as shown below. Where λ is the wavelength, x is any horizontal distance and ϕ is the phase angle corresponding to the horizontal displacement.

$$\lambda \rightarrow 2\pi$$

$$1 \rightarrow \frac{2\pi}{\lambda}$$

$$x \times 1 \rightarrow \frac{2\pi}{\lambda} \times x$$

$$\therefore \phi = \frac{2\pi x}{\lambda}$$

..... Equation 1.5

ACTIVITY 1-1: Properties of waves

The curve of Fig.1.9 shows the variation of height reached by a vibrating object against the horizontal distance it can cover. Study the curve and answer the questions that follow.

From the graph find;

- The amplitude of the wave.
- The wavelength of the wave.
- What do we call point A?

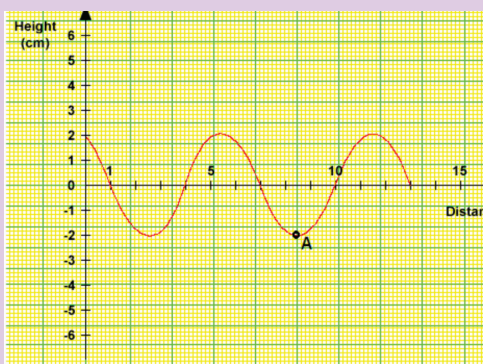

Fig.1.9: Variation of height and distance attained by a vibration.

1.4 BLACKBODY RADIATION

1.4.1 Stefan–Boltzmann law for a black body

By 1900 blackbody radiation had been studied extensively, and three characteristics had been established in **Stefan–Boltzmann law for a black body**:

All objects, no matter how hot or cold, emit electromagnetic radiation (thermal radiation) whose total intensity I (the average rate of radiation of energy per unit surface area per unit time or average power per area) emitted from the surface of an ideal radiator is proportional to the fourth power of the Kelvin (absolute) temperature.

$$I = \frac{E}{tA} = \frac{P}{A} = \varepsilon\sigma T^4 \quad \text{..... Equation 1.6}$$

Where

- $\sigma = 5.670 \times 10^{-8} \text{ W / m}^2 \cdot \text{K}^4$ is called the *Stefan–Boltzmann constant*.
- ε emissivity, $\varepsilon = 1$ for perfect radiator (*blackbody*)
- A is radiating area, P radiated power and T temperature of radiator

Example 1.3: Stefan–Boltzmann law for a black body

1. A metal sphere with a black surface and radius 30 mm, is cooled to -73°C and placed inside an enclosure at temperature of 27°C . Calculate the initial rate of temperature rise of the sphere, assuming the sphere is a black body. (assume density of metal $\rho = 8\,000 \text{ kg / m}^3$, specific heat capacity of metal $c = 400 \text{ J / kg}\cdot\text{K}$ and Stefan Boltzmann $\sigma = 5.670 \times 10^{-8} \text{ W / m}^2 \cdot \text{K}^4$)

Answer

Area: $A = 4\pi r^2$, $T = -73 + 273 = 200 \text{ K}$, $T = 27 + 273 = 300 \text{ K}$

Since the temperature of the surroundings is given by the sphere, the energy emitted per second,

$$P_e = \sigma A(T^4 - T_0^4) = 4\pi\sigma r^2(T^4 - T_0^4)$$

The mass of the sphere $m = \rho V = \frac{4\pi r^3 \rho}{3}$

The energy received per second: $P_r = \frac{cm\Delta T}{t} = \frac{4\pi r^3 \rho c \Delta T}{3t}$

Assuming radiative equilibrium, The power emitted by sphere is equal to the power received by surrounding i.e. $P_e = P_r$

Therefore $\frac{4\pi r^3 \rho c \Delta T}{3t} = 4\pi \sigma r^2 (T^4 - T_0^4) \Leftrightarrow \frac{\Delta T}{t} = \frac{3\sigma(T^4 - T_0^4)}{r\rho c}$

$$\frac{\Delta T}{t} = \frac{3 \times 5.7 \times 10^{-8} (300^4 - 200^4)}{30 \times 10^{-3} \times 8000 \times 400} = 0.012 \text{ K / s}$$

1.4.2 Wien's displacement law

Fig, 1.10 shows the measured spectral emittances $I(\lambda)$ for blackbody radiation at three different temperatures. Each has a peak wavelength λ_m at which the emitted intensity per wavelength interval is largest.

Experiment shows that λ is inversely proportional to T , so their product is constant. This observation is called the **Wien displacement law**.

$$\lambda_m T = 2.90 \times 10^{-3} \text{ m} \cdot \text{K} \quad \text{..... Equation 1.7}$$

The experimental value of the constant is $2.90 \times 10^{-3} \text{ m} \cdot \text{K}$

The spectrum of the radiation depends on the temperature and the properties of the object.

At normal temperatures we are not aware of this electromagnetic radiation because of its low intensity. At higher temperatures, there is sufficient infrared radiation that we can feel heat if we are close to the object. At still higher temperatures (on the order of 1000 K), objects actually glow, such as a red-hot electric stove burner or the heating element in a toaster. At temperatures above 2000 K, objects glow with a yellow or whitish color, such as white-hot iron and the filament of a light bulb

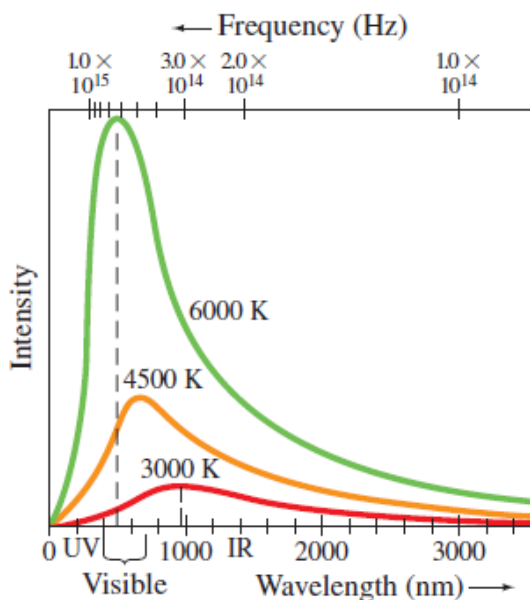

Fig.1. 10 Spectrum of light emitted by a hot dense object for an idealization blackbody

The spectrum of light emitted by a hot dense object is shown in Fig. 1.10 for an idealized **blackbody**. The radiation such an idealized blackbody would emit when hot and luminous, called **blackbody radiation** (though not necessarily black in color), and approximates that from many real objects. The 6000 K curve in Fig. 1.10, corresponding to the temperature of the surface of the Sun, peaks in the visible part of the spectrum. For lower temperatures, the total intensity drops considerably and the peak occurs at longer wavelengths (or lower frequencies). This is why objects glow with a red color at around 1000 K. Measured spectra of wavelengths and frequencies emitted by a blackbody at three different temperatures.

Example 1.4: The Sun's surface temperature and temperature

1. Estimate the temperature of the surface of our Sun, given that the Sun emits light whose peak intensity occurs in the visible spectrum at around 500 nm.

Answer

We assume the Sun acts as a blackbody, and use in Wien's law (Eq. 1.08).

$$T = \frac{2.90 \times 10^{-3} \text{ m} \cdot \text{K}}{\lambda_p} = \frac{2.90 \times 10^{-3} \text{ m} \cdot \text{K}}{500 \times 10^{-9} \text{ m}} = 6000 \text{ K}$$

Application Activity 1.2

- Electromagnetic radiations are emitted by which of the following?
 - Only by radio and television transmitting antennas
 - Only bodies at temperature higher than their surrounding
 - Only by red-hot bodies
 - By all bodies
- Which of the following statements is true regarding how blackbody radiation changes as the temperature of the radiating object increases?
 - Both the maximum intensity and the peak wavelength increase.
 - The maximum intensity increases, and the peak wavelength decreases.
 - Both the maximum intensity and the peak wavelength decrease.
 - The maximum intensity decreases, and the peak wavelength increases.
- Which of the following statements is true regarding how blackbody radiation changes as the temperature of the radiating object increases?
 - Both the maximum intensity and the peak wavelength increase.
 - The maximum intensity increases, and the peak wavelength decreases.
 - Both the maximum intensity and the peak wavelength decrease.
 - The maximum intensity decreases, and the peak wavelength increases.
- A black body is one that
 - Transmit all incident radiations
 - Absorbs all incident radiations
 - Reflects all incident radiations
 - Absorbs, reflects and transmits all incident radiations
- The black body spectrum of an object A has its peak intensity at 200 nm while that of another object of same shape and size has its peak at 600 nm. Compare radiant intensities of the two bodies.

6. The sun emits mostly in the visible region. Compare the total intensity of radiation emitted by a star of similar size as the sun whose surface temperature is 7 200 K.
7. Estimate the radiant energy emitted by a blackbody at 6 000 K
8. The sun's surface temperature is 5 700 K. How much power is radiated by one square meter of the sun's surface? Given that the distance to earth is about 200 sun radii, what is the maximum power possible from a one square kilometer solar energy installation?

ACTIVITY 1-2: Blackbody Radiation

Discuss blackbody radiation in group and ask questions.

1.5 ENERGY, MASS AND MOMENTUM OF A PHOTON

The famous Einstein equation of energy of the photon is $E = mc^2$. In short, the equation describes how energy and mass are related with speed of light. To derive this equation, consider an X-ray photon of mass m hitting the surface of a metal and consider if a part of its energy is gained by a surface electron and is then emitted.

The most important laws in dynamics are those that state the conservation of energy and the conservation of momentum. These two laws can be applied whenever we have a closed system; that is, a system that does not interact with its surroundings. They assert that for such systems and any process they may undergo. Assume that; E is the energy, s is the distance, F is the force, c is the speed, t is the time, and P is the momentum

$$\sum E_i = \sum E_f$$

$$\sum P_i = \sum P_f$$

The total energy of the photon is given by

$$E = F \times s \quad \text{..... Equation 1.8}$$

The distance moved by the photon in time t second is

$$s = ct$$

$$E = F \times ct. \quad \text{..... Equation 1.9}$$

where c is the speed of the photon.

$$\therefore E = Fct \quad \text{..... Equation 1.10}$$

From Newton's second law of motion, the momentum of the photon is given by;

$$P = Ft = mc \quad \text{..... Equation 1.11}$$

$$\therefore F = \frac{mc}{t} \quad \text{..... Equation 1.12}$$

Substituting Equation 1.12 into Equation 1.9 gives the total energy of the photon in the form;

$$E = \frac{mc}{t} (ct)$$

$$E = mc^2 \quad \text{..... Equation 1.13}$$

Equation 1.11 can be derived by integration using the theory of special relativity.

Application Activity 1.3

The mass of an electron or positron is 9.11×10^{-31} kg. The speed of light is 3.0×10^8 m/s.

1. Show that the rest energy of an electron is 8.2×10^{-14} J.
2. Use the answer to question 1, to show that the rest energy of an electron is 0.51 MeV.
3. Write down the rest energy of a positron (antielectron).
4. An electron and a positron meet and annihilate one another. By how much does the rest energy decrease in total? Express the answer in MeV.
5. The annihilation of an electron and a positron at rest produces a pair of identical gamma ray photons travelling in opposite directions. Write down (in MeV) the energy you expect each photon to have.
6. A single photon passing near a nucleus can create an electron-positron pair. Their rest energy comes from the energy of the photon. Write down the smallest photon energy that can produce one such pair.
7. Cosmic rays can send high-energy photons through the atmosphere. What approximately is the maximum number of electron-positron pairs that a 10 GeV photon can create?

1.6 COMPTON EFFECT AND PHOTON INTERACTIONS

1.6.1 Compton effect

The *Compton Effect* concerns the inelastic scattering of X-rays by electrons. Scattering means dispersing in different directions and inelastic means that energy is lost by the scattered object in the process. The intensity of the scattered X-ray is measured as a function of the wavelength shift.

Photons are electromagnetic radiation with zero mass, zero charge, and a velocity that is always equal to the speed of light. Because they are electrically neutral, they do not steadily lose energy via Coulombic interactions with atomic electrons, as charged particles do. Photons travel some considerable distance before undergoing a more “catastrophic” interaction leading to partial or total transfer of the photon energy to electron energy. These electrons will ultimately deposit their energy in the medium. Photons are far more penetrating than charged particles of similar energy. There are many types of photon interactions. We will only discuss those that are important in radiation therapy and/or diagnostic radiology.

1.6.2 Types of photon interactions

Coherent scattering

Coherent scattering is one of three forms of photon interaction which occurs when the energy of the X-ray or gamma photon is small in relation to the ionisation energy of the atom. It therefore occurs with low energy radiation.

Upon interacting with the attenuating medium, the photon does not have enough energy to liberate the electron from its bound state (i.e. the photon energy is well below the binding energy of the electron), so no energy transfer occurs. The only change is a change of direction (scatter) of the photon, hence it is called ‘unmodified’ scatter. Coherent scattering is not a major interaction process encountered in radiography at the energies normally used. There are two types of coherent scattering: Thomson scattering and Rayleigh scattering.

- In Thomson scattering, only one electron of the atom is involved in the interaction.
- With Rayleigh scattering, all the electrons of the atom, sometimes called the electron cloud, are involved in a cooperative effort in the interaction with the photon.

Photoelectric effect

The following points make this phenomena clear:

1. The photon must have an energy equal to or greater than the binding energy of electron in the atom.

2. The incident photon must be completely absorbed by the electron.
3. The electron is then ejected from the atom.
4. The excess energy over the binding energy is given to the electron in the form of kinetic energy (which is the speed of the electron).
5. The hole left in the atom is filled by an outer shell electron or a free electron with the emission of characteristic radiation.

Compton interaction

In Compton interaction, the photon interacts with a ‘free’ or an outer shell electron. A portion of incident energy of the photon will be transferred to an electron in the form of kinetic energy. The incident photon, now called a scattered photon will be deflected in a new direction with less energy. Energy given to recoil electron is considered as the absorbed energy and the energy retained by the photon is considered scattered.

Pair Production

The photon interacts with the nuclear field of the atom, in such a way, that the photon transforms itself into an electron-positron pair. As the photon interacts with the strong electric field around the nucleus, it undergoes a change of state and is transformed into two particles (essentially creating matter from energy).

Photodisintegration

(Photo transmutation) It is a nuclear reaction in which the absorption of high energy electromagnetic radiation (a gamma-ray photon) causes the absorbing nucleus to change to another species by ejecting a subatomic particle, such as a proton, neutron, or alpha particle.

ACTIVITY 1-2: Compton Effect.

Aim: In this activity you will be able to highlight the most important terms in Compton effect

Question: highlight at least 17 important terms you may need to explain photoelectric effect and photo interaction. Use these terms to construct at least 5 sentences to explain this theory

V	T	A	O	I	W	A	T	X	O	W	O	O	D	R	O	P	S	S	E	A	S	U	P	T	S
S	C	A	T	T	E	R	I	N	G	A	C	A	N	U	M	B	E	P	H	X	D	E	E	X	Z
A	M	X	Q	Q	I	Y	P	H	O	T	O	D	I	S	I	N	T	E	G	R	A	T	I	O	N
O	W	A	A	D	B	C	O	U	L	O	M	B	I	C	L	X	U	E	F	A	C	H	P	L	P
E	L	W	C	T	R	O	N	A	T	E	P	U	I	O	N	I	P	D	S	Y	J	O	O	S	O
S	X	I	N	C	O	H	E	R	E	N	T	O	S	D	Q	Z	T	M	D	U	H	M	L	V	O
U	O	P	O	T	S	M	L	E	P	R	O	D	U	C	T	I	O	N	U	S	O	S	F	X	S
A	I	N	T	E	R	A	C	T	I	O	N	L	T	I	T	T	L	K	O	T	S	O	X	D	Z
O	S	M	C	O	S	U	N	M	O	D	I	F	I	E	D	I	P	H	O	T	O	N	T	P	K

1.7 THE WAVE NATURE OF MATTER

Being fully aware of the pioneering work of Einstein on the photoelectric effect, de Broglie extended the notion of wave particle duality to matter.

All matter can exhibit wave-like behaviour. For example, a beam of electron can be diffracted just like a beam of light or a water wave.

The concept that matter behaves like a wave is also referred to de Broglie hypothesis.

The de Broglie wavelength is the wavelength, λ , associated with a massive particle and is related to its momentum p .

$$\lambda = \frac{h}{p} \quad \text{..... Equation 1.14}$$

With p being the particle's momentum. The particles are diffracted by passing through an aperture in a similar manner as light waves. The wave properties of particles mean that when you confine it in a small space its momentum and kinetic energy must increase.

For a nonrelativistic particle, we have: $E = \frac{p^2}{2m} = eV$ Equation 1.15

The momentum of a photon is given by $p = \frac{E}{c} = \frac{hf}{c} = \frac{h}{\lambda}$ Equation 1.16

And the wavelength λ of light is given by $\lambda = \frac{c}{f}$ Equation 1.17

According to classical mechanics, particle is a point like object having position and momentum, whereas wave is a disturbance in some space.

Example 1.5: Wave-particle nature of matter

1. Determine de Broglie wavelength for

- a) an electron moving at speed of $6.0 \times 10^6 \text{ m/s}$.
- b) a baseball (mass 0.15 kg) moving at speed of 13 m/s.

answer

a) For de Broglie wavelength equation:

$$E = \frac{h}{mv} = \frac{6.63 \times 10^{-34} \text{ m/s}}{(9.1 \times 10^{-31} \text{ kg})(6.0 \times 10^6 \text{ m/s})} = 1.2 \times 10^{-10} \text{ m}$$

This wavelength is about the size of the interatomic spacing in solid and therefore, leads to the observed diffraction effects.

b) de Broglie wavelength of the baseball:

$$\lambda = \frac{h}{mv} = \frac{6.63 \times 10^{-34} \text{ m/s}}{(9.1 \times 10^{-31} \text{ kg})(13 \text{ m/s})} = 3.3 \times 10^{-34} \text{ m}$$

The de Broglie wavelength is very small as compared to the size of body. This why wave nature of matter is not noticeable in our daily life.

1.8 ELECTRON MICROSCOPE

A microscope can be defined as an instrument that uses one or several lenses to form an enlarged (magnified) image. Microscopes can be classified according to the type of electromagnetic wave employed and whether this wave is transmitted or not through the specimen. The most common electron microscopes are Transmission Electron Microscope (TEM) and Scanning Electron Microscope (SEM).

1.8.1 Transmission electron microscope (TEM)

This is a microscopy technique whereby a beam of electrons is transmitted through an ultra thin specimen, interacting with the specimen as it passes through it. An image is formed from the electrons transmitted through the specimen, magnified and focused by an objective lens. It appears on an imaging screen, a fluorescent screen (in most TEMs), a monitor, or on a layer of photographic film. It can also be detected by a sensor such as a CCD camera. Theoretically, the maximum resolution that one can obtain with a light microscope has been limited by the wavelength of the photons that are being used to probe the sample and the numerical aperture of the system.

TEM consists of a cylindrical tube about 2 metres long. The tube contains vacuum where the specimen is located. This is because the molecules of gases, such as those in air, absorb electrons.

TEM works by emitting electrons from a cathode, then accelerating them through an anode, after which the electrons pass through an aperture into the vacuum tube.

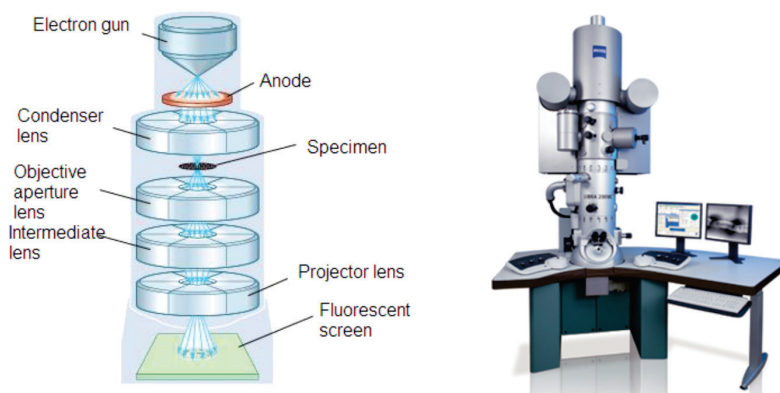

Fig.1.11: Transmission Electron Microscope (TEM)

As it passes down through the tube the electron beam is controlled by electromagnetic lenses formed by coils around the tube (whose effect is moderated by adjusting the electricity flowing through the coils). These electromagnetic lenses direct the electron beam through the centre of the tube to a very thin specimen located part-way down the tube.

Some parts of the specimen might allow electrons to pass through them unaffected. Other regions within the specimen absorb some or all of the electrons that reach them. If any electrons continue from that part of the specimen further down the tube to the image formation plane with less energy. This happens because some of their energy has been absorbed by, or “passed to”, the part of the specimen that the electron(s) passed through.

TEM Applications

- TEMs provide topographical, morphological, compositional and crystalline information.
- It is useful in the study of crystals and metals, but also has industrial applications.
- TEMs can be used in semiconductor analysis and the manufacturing of computer and silicon chips.
- Tech giants use TEMs to identify flaws, fractures and damages to micro-sized objects; this data can help and fix problems and/or help to make a more durable efficient product.
- Colleges and universities can utilize TEMs for research and studies.

1.8.2 Scanning Electron Microscope (SEM)

The SEM is designed for direct study of the surfaces of solid objects. By scanning with an electron beam that has been generated and focussed by the operation of the microscope, an image is formed in the same way as a TV.

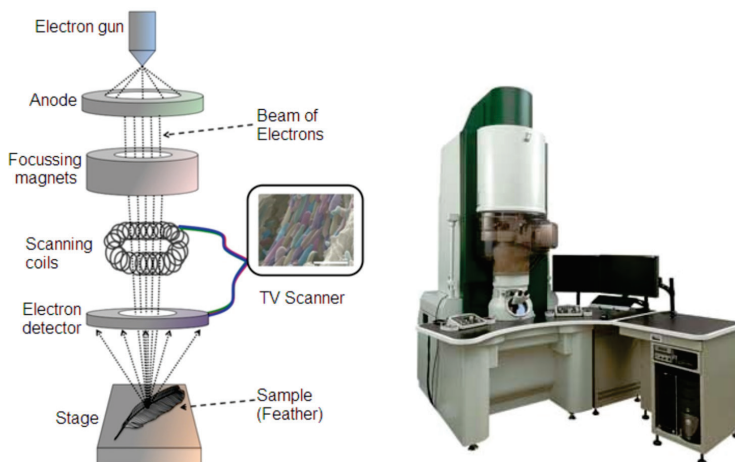

Fig.1.12: Scanning Electron microscope

The SEM allows a greater depth of focus than the optical microscope. For this reason, the SEM can produce an image that is a good representation of the three-dimensional sample.

The SEM uses electrons instead of light to form an image. A beam of electrons is produced at the top of the microscope by heating a metallic filament. The electron beam follows a vertical path through the column of the microscope. It makes its way through electromagnetic lenses which focus and direct the beam down towards the sample. Once it hits the sample, other electrons (backscattered or secondary) are ejected from the sample. Detectors collect the secondary or backscattered electrons, and convert them to a signal that is sent to a viewing screen similar to the one in an ordinary television, producing

an image. To produce an image on the screen, the electron beam scans over the area to be magnified and transfers this image to the TV screen.

Applications of SEM

- Image morphology of samples (eg. view bulk material, coatings, sectioned material, foils, even grids prepared for transmission electron microscopy).
- Image composition and finding some bonding differences (through contrast and using backscattered electrons).
- Image molecular probes: metals and fluorescent probes.
- Undertake micro and nano lithography: remove material from samples; cut pieces out or remove progressive slices from samples (eg. using a focussed ion beam).
- Heat or cool samples while viewing them (it is generally done only in ESEM or during Cryo-scanning electron microscopy).
- Wet and dry samples while viewing them (only in an ESEM)
- View frozen material (in an SEM with a cryostage)
- Generate X-rays from samples for microanalysis (EDS; WDS) to determine chemical composition.
- Study optoelectronic behaviour of semiconductors using cathodoluminescence
- View/map grain orientation/crystallographic orientation and study related information like heterogeneity and microstrain in flat samples (Electron backscattered diffraction).
- Electron diffraction using electron backscattered diffraction. The geometry may be different from a transmission electron microscope but the physics of Bragg Diffraction is the same.

END OF UNIT ASSESSMENT

1. Hydrogen has a red emission line at 656.3 nm, what is the energy and frequency of photon of this light?
2. An FM radio transmitter has a power output of 100 kW and operates at a frequency of 94 MHz. How many photons per second does the transmitter emit?
3. State Huygens' principle. State its application and explain the construction of spherical wavefront.
4. Determine the de Broglie wavelength for the following:
 - a. A moving golf ball ($m = 0.05 \text{ kg}$, $v = 40 \text{ m/s}$),
 - b. An orbiting electron in the ground state of hydrogen (13.6 eV),
 - c. An electron accelerated through 100 kV in an electron microscope.
5. Determine the de Broglie wavelength of the matter wave associated with

a cricket ball of mass 0.175 kg and velocity 23.6 m/s. Use the answer to this question to explain why we do not observe the matter waves associated with macroscopic objects.

6. Blue light of frequency 7.06×10^{14} Hz shines on sodium. Calculate the maximum energy of the photoelectrons released.
7. The range of frequency of ultraviolet rays is 7.9×10^{14} Hz to 5×10^{17} Hz. What is corresponding range of energies of the photons of ultraviolet light? (Plank's constant $h = 6.63 \times 10^{-34} \text{ J} \cdot \text{s}$).
8. Estimate how many visible light photons a 100 W light bulb emits per second. Assume the bulb has a typical efficiency of about 3% (that is, 97% of the energy goes to heat).
9. The following phenomena prove that light can behave like either a particle or a wave: Reflection of light, refraction of light, interference of light, photoelectric effect, Compton effect
 - a. What phenomena best prove that light is a particle instead of wave?
 - b. What phenomena best prove that light is a wave instead of particle?
10. One hundred years ago, Albert Einstein explained the photoelectric effect.
 - a. What is the photoelectric effect?
 - b. Write down an expression for Einstein's photoelectric law.
 - c. Summarise Einstein's explanation of the photoelectric effect
 - d. Give one application of the photoelectric effect.
11. Outline the advantages of Huygen's wave theory of light.
12. If you pick up and shake a piece of metal that has free electrons, no electrons fall out. Yet if you heat the metal, electrons can be boiled off. Explain both of these facts and relate to the amount and distribution of energy involved with shaking the object as compared with heating it.
13. Which formula may be used for the momentum of all particles, with or without mass?
14. Is there any measurable difference between the momentum of a photon and the momentum of matter?
15. Describe one type of evidence for the wave nature of matter.
16. Describe one type of evidence for the particle nature of EM radiation.

UNIT SUMMARY

Wave theory of monochromatic light: If light consists of undulations in an elastic medium, it should diverge in every direction from each new centre of disturbance, and so, like sound, bend round all obstacles and obliterate all shadow.

A wave is any disturbance that results into the transfer of energy from one point to another point.

Primary source: The geometrical centre or axis of the actual source of light which is either a point or a line is called the primary source.

Wavelets: All points lying on small curved surfaces that receive light at the same time from the same source (primary or secondary) are called wavelets.

Secondary source: Any point on a wavelet, acts as the source of light for further propagation of light. It is called a secondary source.

Wavefront: The envelope of all wavelets in the same phase-receives light from sources in the same phase at the same time is called a wavefront.

Wave normal: The normal at any point drawn outward on a wave front is called the wave normal. Further propagation of light occurs along the wave normal. In isotropic media the wave normal coincides with the 'ray of light'.

A **black body** is a theoretical object that absorbs 100% of the radiation that hits it and re-radiates energy which is characteristic of this radiating system or body only.

The *mass*, *energy* and *momentum* of a photon are related according to equations;

$$E = mc^2 \quad P = \frac{E}{c}$$

Compton effect says that when X-rays are projected on the target, they are scattered after hitting the target and change the direction in which they were moving.

Photon interactions: because photons are electrically neutral, they do not steadily lose energy via coulombic interactions with atomic electrons, as do charged particles. Photon interactions include; **Coherent Scattering**, **Photoelectric Effect**, **Compton Interaction**, **Pair Production** and **Photodisintegration**.

Wave-particle duality of light: According to different experiments and properties, light behaves as waves as well as particles.

Principle of complementarities: Both properties of light being a wave and a particle are necessary to gaining complete knowledge of the phenomena; they are complementary to each other but at the same time they also exclude each other.

The wave nature of matter: The attribution of a wavelength to a massive particle implies that it should behave as a wave under some conditions.

Electron microscope: is an instrument that uses one or several lenses to form an enlarged (magnified) image. The most common electron microscopes are Transmission Electron Microscopes (TEM) and Scanning Electron Microscope (SEM).

SIMPLE HARMONIC MOTION

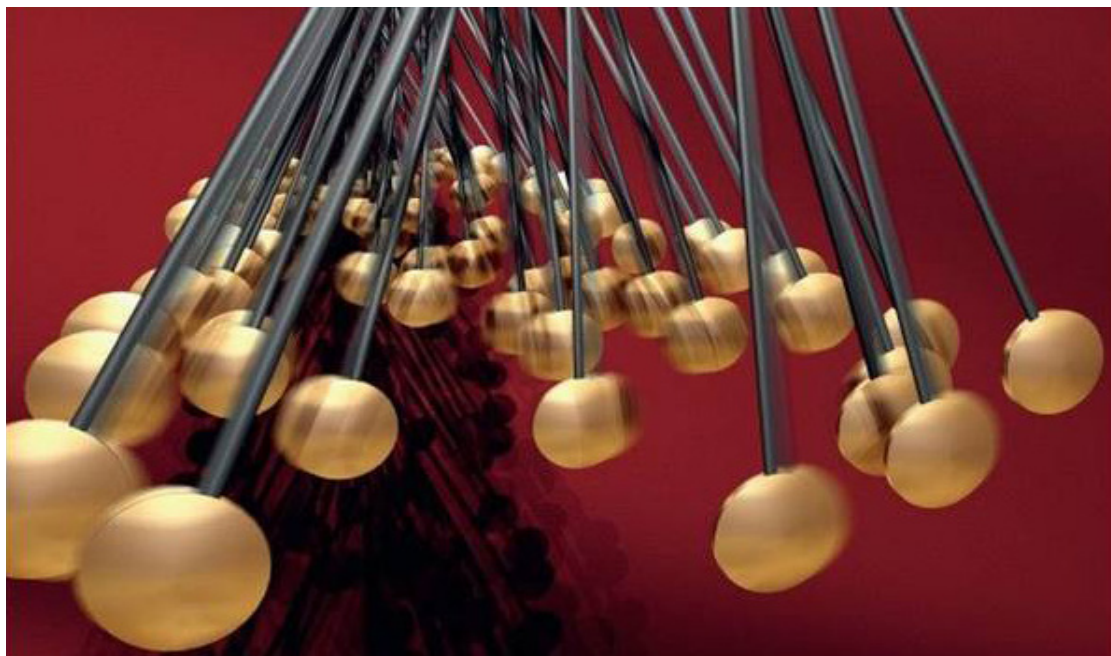

Key unit competence: By the end of the unit I should be able to analyze energy changes in simple harmonic motion.

Unit Objectives:

By the end of this unit I will be able to;

- ◇ Determine the periodic time of an oscillating mass by practically and by calculation accurately.
- ◇ Derive and apply the equation of simple harmonic motion correctly
- ◇ Determine the periodic time of the simple pendulum correctly.

Introductory Activity

- a. Clearly analyze the images of Fig. 2-1 given below and explain what you think would happen in each case when the mass is displaced.

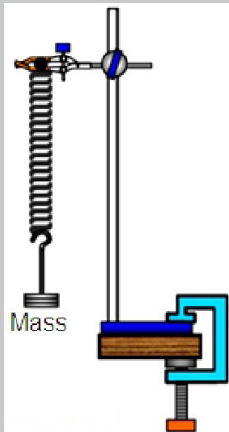

Fig. 2-1(a)

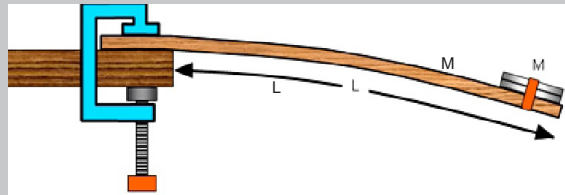

Fig. 2-1(b)

Fig. 2.1. (a) Mass on the spring

(b) Mass on the meter rule

- b. Basing on your daily experiences, what other systems do you think behave the same way as fig 2.1(shown above) when displaced?
- c. Discuss fields where those systems you mentioned in b) above are applied.

2.0 INTRODUCTION

You are familiar with many examples of repeated motion in your daily life. If an object returns to its original position a number of times, we call its motion repetitive. Typical examples of repetitive motion of the human body are heartbeat and breathing. Many objects move in a repetitive way, such as a swing, a rocking chair and a clock pendulum. Probably the first understanding of repetitive motion grew out of the observations of motion of the sun and phases of the moon.

Strings undergoing repetitive motion are the physical basis of all string musical instruments. What are the common properties of these diverse examples of repetitive motion?

In this unit we will discuss the physical characteristics of repetitive motion and develop techniques that can be used to analyze this motion quantitatively.

Opening question

Clearly analyse the images of Fig. 2-1 given below and explain what you think will happen in each case when the mass is displaced.

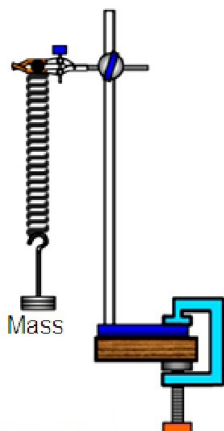

Fig. 2-1(a)

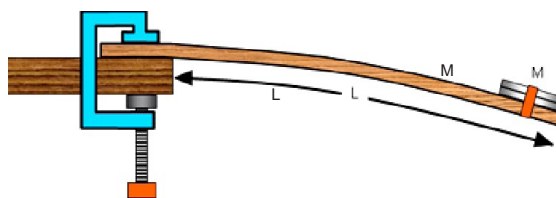

Fig. 2-1(b)

Fig. 2.1. (a) Mass on the spring

(b) Mass on the meter rule

2.1 KINEMATICS OF SIMPLE HARMONIC MOTION

One common characteristic of the motions of the heartbeat, clock pendulum, violin string and the rotating phonograph turntable is that each motion has a well defined time interval for each complete cycle of its motion. Any motion that repeats itself with equal time intervals is called **periodic motion**. Its period is the time required for one cycle of the motion.

In Mechanics we showed that **simple harmonic motion** occurs *when the force acting on an object or system is directly proportional to its displacement x from a fixed point and is always directed towards this point:*

$$F = -kx$$

..... Equation 2.1

The negative sign in Eq. 2.01 implies that the force is opposite to the displacement.

To stretch the spring a distance x , an (external) force must be exerted on the free end of the spring with a magnitude at least equal to

$$F_{ex} = kx$$

The greater the value of k , the greater the force needed to stretch a spring a given distance. That is, the stiffer the spring, the greater the spring constant k .

Consider a physical system that consists of a block of mass m attached to the end of a spring, with the block free to move on a horizontal, frictionless surface (Fig. 2.2). When the spring is neither stretched nor compressed, the block is at the position called the *equilibrium position* of the system. If disturbed from its equilibrium position such a system oscillates back and forth.

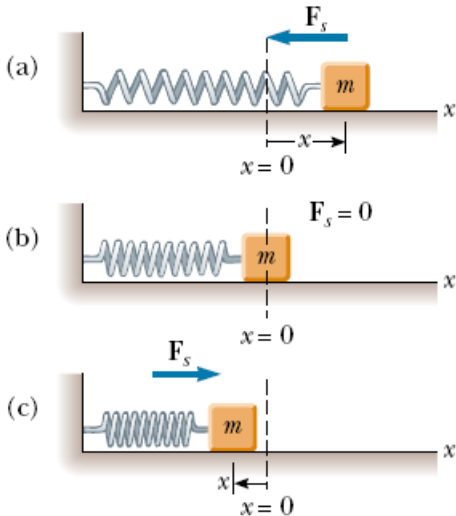

Fig.2. 2 A block attached to a spring moving on a frictionless surface. (a) When the block is displaced to the right of equilibrium ($x > 0$), the force exerted by the spring acts to the left. (b) When the block is at its equilibrium position ($x = 0$), the force exerted by the spring is zero. (c) When the block is displaced to the left of equilibrium ($x < 0$), the force exerted by the spring acts to the right.

Recall that when the block is displaced a small distance x from equilibrium, the spring exerts on the block a force that is proportional to the displacement and given by **Hooke's law (Eq. 2.01)**.

We call this a **restoring force** because it is always directed toward the equilibrium position and therefore *opposite* the displacement. That is, when the block is displaced to the right of in Figure above, then the displacement is positive and the restoring force is directed to the left. When the block is displaced to the left of then the displacement is negative and the restoring force is directed to the right.

Applying Newton's second law to the motion of the block, together with Equation 2.01, we obtain

$$a = \frac{F}{m} \Leftrightarrow \frac{d^2x}{dt^2} = -\frac{kx}{m} \Leftrightarrow \frac{d^2x}{dt^2} + \frac{k}{m}x = 0$$

If we denote the ratio $\omega^2 = \frac{k}{m}$ and $\omega = 2\pi f$ angular frequency this equation becomes

$$\frac{d^2x}{dt^2} + \omega^2 x = 0 \quad \text{..... Equation 2.2}$$

This is second-order differential equation of SHM. Most general solution for (2.02) is

$$x = A \sin(\omega t + \varphi) \quad \text{..... Equation 2.3}$$

Where:

- φ is known as the phase angle of the oscillation. It represents the phase difference between the oscillations.
- A is the greatest displacement from the mean or equilibrium position and is amplitude of the motion.
- The constant $\omega = 2\pi f$ where f is the frequency of oscillation or number of cycles per second is called angular frequency or angular velocity

If the object moves with SHM, the variation of the **displacement** x with time t is a sine relation.

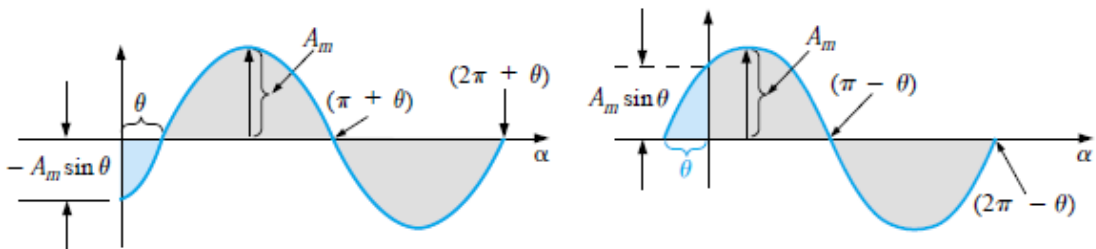

Fig.2. 3 Defining the phase angle for a sinusoidal function that crosses the horizontal axis with a \pm positive slope after 0°

We can obtain the **linear velocity** of a particle undergoing simple harmonic motion by differentiating Equation 2.03 with respect to time:

$$v = \frac{dx}{dt} = A\omega \cos(\omega t + \varphi) \quad \text{..... Equation 2.4}$$

We can express the **velocity** v in terms of A and r . From $x = A \sin(\omega t + \phi)$ and $v = A\omega \cos(\omega t + \phi)$

We have $\frac{x}{A} = \sin(\omega t + \phi)$ and $\frac{v}{A\omega} = \cos(\omega t + \phi)$

Now $\frac{x^2}{A^2} + \frac{v^2}{A^2\omega^2} = \sin^2(\omega t + \phi) + \cos^2(\omega t + \phi) \Leftrightarrow \frac{x^2}{A^2} + \frac{v^2}{A^2\omega^2} = 1$

Simplifying $v = \pm\omega\sqrt{A^2 - x^2}$ Equation 2.5

The graph of the variation of velocity v with displacement x is an ellipse.

We have maximum velocity when $x = 0$. From (2.05) the maximum velocity is given by $v = \omega A$ Equation 2.6

The acceleration of the particle is given:

$$a = -A\omega^2 \sin(\omega t + \phi) = -x\omega^2 \quad \text{..... Equation 2.7}$$

We have maximum acceleration when $x = A$.

From this equation we see that the acceleration is proportional to the displacement of the body, and its direction is opposite the direction of the displacement. Systems that behave in this way are said to exhibit **simple harmonic motion**.

The curves in Fig.2.4 show that at the time of zero velocity 2.4a, the acceleration and the displacement are maximum. At a time of maximum velocity Fig.2.4b, the acceleration and the displacement are zero. We say that they are out of phase of π (opposite phase) while velocity and displacement are

out of phase of $\frac{\pi}{2}$ since velocity is zero where displacement is maximum

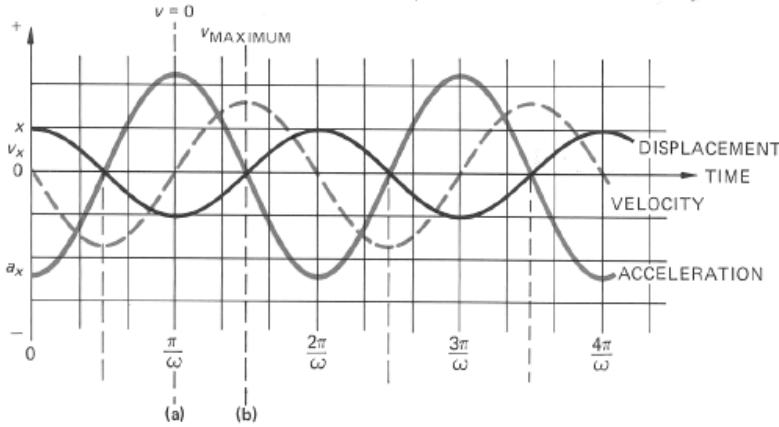

Fig.2. 4 Acceleration and displacement are out of phase of π (opposite phase) velocity and displacement are out phase of $\frac{\pi}{2}$,

EXAMPLE 2.1

A particle moving with SHM has velocities 4 cm/s and 3 cm/s at distances 3 cm and 4 cm respectively from equilibrium position. Find

- (a) the amplitude of oscillation
- (b) the period
- (c) velocity of the particle as it passes through the equilibrium position.

Solution:

Given $v_1 = 4 \text{ cm/s}$, $x_1 = 3 \text{ cm}$, $v_2 = 3 \text{ cm/s}$, $x_2 = 4 \text{ cm}$

From equation 2-9;

$$v_1 = \pm\omega\sqrt{A^2 - x_1^2}, v_2 = \pm\omega\sqrt{A^2 - x_2^2}$$

(a)
$$4 = \pm\omega\sqrt{A^2 - 3^2}$$

$$3 = \pm\omega\sqrt{A^2 - 4^2}$$

Dividing these two equations gives

$$\frac{4}{3} = \frac{\sqrt{A^2 - 9}}{\sqrt{A^2 - 16}}$$

Squaring both sides will give;

$$\Rightarrow \frac{16}{9} = \frac{A^2 - 9}{A^2 - 16}$$

$$\Rightarrow A = 5 \text{ cm}$$

- (b) Let us find the period at a velocity of 4 cm/s and displacement 3 cm. Both cases give the same value of angular velocity ω .

$$T = \frac{2\pi}{\omega} = \frac{2\pi\sqrt{5^2 - 9}}{4} = 2\pi \quad \text{or} \quad T = 6.28 \text{ s}$$

$$\text{Hence, } \omega = \frac{2\pi}{T} = \frac{2\pi}{2\pi} = 1 \text{ rad.s}^{-1}$$

- (c) As the particle passes the equilibrium position, it has the maximum velocity;

$$v_{\max} = \pm 1 \times 5 = \pm 5 \text{ cm/s (from eq. 1)}$$

EXAMPLE 2.2

A simple pendulum has a period of 2.0 s and amplitude of swing 5.0 cm. Calculate the maximum magnitude of

- (a) velocity of the bob
(b) acceleration of the bob.

Solution:

$$(a) \quad v_{\max} = \frac{2\pi A}{T} = \frac{2\pi \times 5}{2} = 15.71 \text{ m/s}$$

$$(b) \quad a_{\max} = -\frac{4\pi^2 A}{T^2} = \frac{4\pi^2 \times 5}{4} = 49.39 \text{ m/s}^2 \text{ (Negative sign will be neglected for minimum acceleration.)}$$

The **period** T of the motion is the time to make a complete to-and-fro movement or cycle.

$$T = \frac{2\pi}{\omega} = 2\pi \sqrt{\frac{m}{k}} \quad \text{..... Equation 2.8}$$

The **frequency** f of a simple harmonic motion is the number of complete (to-and-fro) oscillations per second. Since one oscillation is made in a time T , then

$$f = \frac{1}{T} = \frac{1}{2\pi} \sqrt{\frac{k}{m}} \quad \text{..... Equation 2.9}$$

The unit of frequency is the *hertz* (Hz), where 1 Hz = 1 cycle/s.

The frequency and period depend only on the mass of the block and on the force constant of the spring. Furthermore, the angular frequency, the frequency and period are independent of the amplitude of the motion

EXAMPLE 2.3: PERIOD, FREQUENCY, AND ANGULAR FREQUENCY

1. A car with a mass of 1 300 kg is constructed so that its frame is supported by four springs. Each spring has a force constant of 20 000 N/m.

(a) If two people riding in the car have a combined mass of 160 kg, find the frequency of vibration of the car after it is driven over a pothole in the road and what is the angular frequency.

(b) How long does it take the car to execute two complete vibrations?

Answer

We assume that the mass is evenly distributed. Thus, each spring supports one fourth of the load. The total mass is 1 460 kg, and therefore each spring supports 365 kg.

a) Hence, the frequency of vibration is, from Equation 2.09

$$f = \frac{1}{2\pi} \sqrt{\frac{k}{m}} = \frac{1}{2\pi} \sqrt{\frac{20\,000}{365}} = 1.18 \text{ Hz}$$

The angular frequency $\omega = 2\pi f = \sqrt{\frac{k}{m}} = \sqrt{\frac{20\,000}{365}} = 7.40 \text{ rad/s}$

b) The period of vibration is, from equ.2.08: $T = 2\pi \sqrt{\frac{m}{k}} = 1.70 \text{ s}$

ACTIVITY 2-1: Cantilever

Aim of this activity is to determine the periodic time of a cantilever beam.

Required Materials

Metre rule, G-clamp (or a wooden block), stop watch, set of masses (4×100 g), Cellotape and pair of scissors (can be shared).

Procedure

- Use the apparatus, set up as shown in the diagram. Start with a length L of 80.0 cm.
- Place a 200 g mass at 5 cm from the free end.
- Displace the mass slightly and release it.
- Use a stop-watch to measure the time taken t for 10 complete oscillations
- Calculate the time T for one oscillation.
- Repeat procedures from (b) to (e) for values of $L = 70.0$ cm, 60.0 cm, 50.0 cm, 40.0 cm
- Record your observations in a table. Also include the values of $\log T$ and $\log L$.
- Plot a graph of $\log T$ against $\log L$.

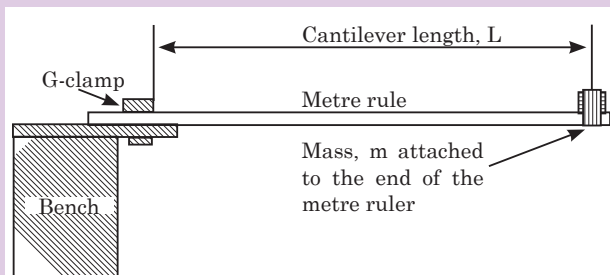

Fig. 2-4. Determination of the periodic time of a cantilever

QUESTIONS

- Measure the gradient, m of your graph.
- Calculate the intercept c on the vertical axis.
- Calculate the constant a of the rule from $c = \log a$.
- Calculate the period of a cantilever from $T = aL^m$
- Calculate the value of T from $\log T = m \log L + \log a$ for value of $L = 70.0$ cm.
- Compare and comment on the results in procedures (l) and (m).

EXAMPLE 2-4

The displacement of an object undergoing simple harmonic motion is given by the equation $x(t) = 3.00 \sin\left(8\pi t + \frac{\pi}{4}\right)$. Where x is in meters, t is in seconds and the argument of the sine function is in radians.

- What is the amplitude of motion?
- What is the frequency of oscillation?
- What are the position, velocity and acceleration of the object at $t = 0$?

Solution:

(a) From $x(t) = 3.00 \sin\left(8\pi t + \frac{\pi}{4}\right) = A \sin(\omega t + \Phi)$

$$\Rightarrow A = 3.00 \text{ m}$$

(b) $f = \frac{\omega}{2\pi} = \frac{8\pi}{2\pi} = 4 \text{ Hz}$

(c) $v = \frac{dx}{dt} = 24\pi \cos\left(8\pi t + \frac{\pi}{4}\right)$

$$\text{At } t = 0; v = 24\pi \cos\left(\frac{\pi}{4}\right) = 53.32 \text{ m/s}$$

Application Activity 2.1

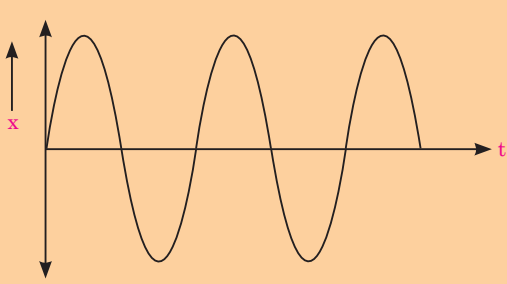
- A body of mass 100 g undergoes simple harmonic motion with amplitude of 20 mm. The maximum force which acts upon it is 0.05 N. Calculate:
 - its maximum acceleration.
 - Its period of oscillation.
- The following graph shows the displacement (x) of a simple harmonic oscillator. Draw graphs of its velocity, momentum, acceleration and the force acting on it.
- A particle undergoes SHM with an amplitude of 8.00 cm and an angular frequency of 0.250 s^{-1} . At $t = 0$, the velocity is 1.24 cm/s . Determine:
 - The equations for displacement and velocity of the motion.
 - The initial displacement of the particle.

2.2 SIMPLE HARMONIC OSCILLATORS

A simple harmonic oscillator is a physical system in which a particle oscillates above and below a mean position at one or more characteristic frequencies. Such systems often arise when a contrary force results from displacement from a force-neutral position and gets stronger in proportion to the amount of displacement. Below are some of the physical oscillators;

2.2.1 Simple Pendulum

A simple pendulum consists of a small bob of mass m suspended from a fixed support through a light, inextensible string of length L as shown on Fig.2-5. This system can stay in equilibrium if the string is vertical. This is called the mean position or the equilibrium position. If the particle is pulled aside and released, it oscillates in a circular arc with the center at the point of suspension 'O'.

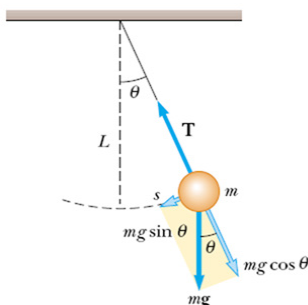

Fig. 2-5. Simple pendulum

The driving force on the bob is always equal to the restoring force at any point during an oscillation but acts in opposite direction. This restoring force is a component of weight $mg \sin \theta$.

$$ma = -mg \sin \theta$$

$$a = -g \sin \theta \quad \dots\dots\dots \text{Equation 2-10}$$

If the bob is slightly displaced and the angle θ is small, B is close to A and triangle AOB becomes a right angled triangle, then

$$\sin \theta = \frac{AB}{L} = \frac{s}{L}$$

Where s is the horizontal displacement of the bob, g is acceleration due to gravity and L is the length of the string;

$$\therefore a = -g \frac{s}{L}$$

$$\Rightarrow a = -\left(\frac{g}{L} \times s\right) \quad \dots\dots\dots \text{Equation 2-11}$$

The value $\frac{g}{L}$ of the equation 2-11 is constant. This means that

$$a \propto -s \quad \dots\dots\dots \text{Equation 2-12}$$

Equation 2-12 shows that acceleration is directly proportional to displacement and is opposite to it. So the bob executes S.H.M;

Comparing equation 2-7 and equation 2-12 gives

$$\begin{aligned}\omega^2 &= \frac{g}{L} \\ \omega &= \sqrt{\frac{g}{L}} \text{ and } \omega = \frac{2\pi}{T} \\ \frac{2\pi}{T} &= \sqrt{\frac{g}{L}} \\ T &= 2\pi\sqrt{\frac{L}{g}} \quad \dots\dots\dots \text{Equation 2-13}\end{aligned}$$

Equation 2-18 represents the periodic time of a simple pendulum. Thus, the following are the factors affecting the periodic time of the simple pendulum;

- Length of string
- Acceleration due to gravity

EXAMPLE 2.5

A small piece of lead of mass 40 g is attached to the end of a light string of length 50 cm and it is allowed to hang freely. The lead is displaced to 0.5 cm above its rest position, and released.

- (a) Calculate the period of the resulting motion, assuming it is simple harmonic.
- (b) Calculate the maximum speed of the lead piece. (Take $g = 9.81 \text{ m}\cdot\text{s}^{-2}$)

Solutions:

- (a) To calculate the time period equation 2-26 can be used

$$\begin{aligned}T &= 2\pi\sqrt{\frac{L}{g}} \\ T &= 2\pi\sqrt{\frac{0.5}{9.81}} = 1.42 \text{ s}\end{aligned}$$

- b) Use kinematics equation:

$$v^2 - u^2 = 2gs \Leftrightarrow v = \sqrt{2gs} = \sqrt{2 \times 9.81 \times 0.005} = 0.31 \text{ m/s}$$

EXAMPLE 2.6

What happens to the period of a simple pendulum if the pendulum's length is doubled? What happens to the period if the mass of the suspended bob is doubled?

Solutions:

$$T_i = 2\pi \sqrt{\frac{L_i}{g}}$$

and

$$T_f = 2\pi \sqrt{\frac{L_f}{g}}$$

But

$$L_f = 2L_i$$

$$T_f = 2\pi \sqrt{2 \times \frac{L_i}{g}}$$

⇒

$$T_f = \sqrt{2} \times T$$

Conclusion: The time period gets larger by $\sqrt{2}$ times. Changing the mass has no effect on the time period of a simple pendulum.

ACTIVITY 2-2: Acceleration due to Gravity

The aim of this activity is to determine the acceleration due to gravity using oscillation of a simple pendulum Apparatus

Cotton thread, small pendulum bob, metre rule, stopwatch, retort stand/clamp stand.

Procedure

- Set up a small simple pendulum, as shown in the diagram.
- Keeping the angle of swing, θ less than 10° (approximately) for the values of $L = 20$ cm, 30 cm, 40 cm, 50 cm, 60 cm, 70 cm, 80 cm, 90 cm respectively, measure the time period t for 10 oscillations and calculate time period T for one oscillation.
- Record your results in a suitable table including the values of T^2 .
- Plot a graph of T^2 against L .
- Calculate the slope S of the graph
- Find the value of acceleration due to gravity g from $S = \frac{4\pi^2}{g}$

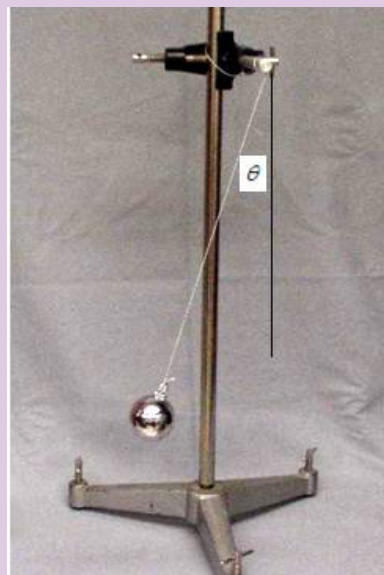
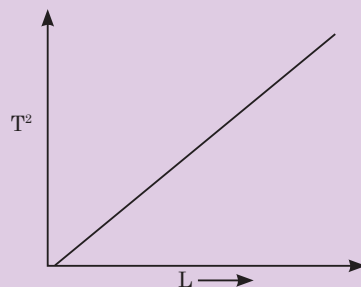

Fig.2-6; Oscillation of bob



2.2.2 Mass suspended from a Coiled Spring

The extension of the spiral spring which obeys Hook's law is directly proportional to the extending tension. A mass m is attached to the end of the spring which exerts a downward tension mg on it and stretches it by e as shown in Fig.2-7 below;

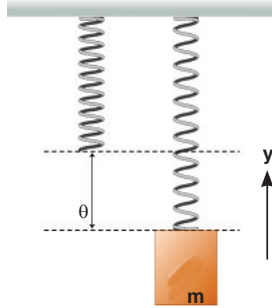

Fig. 2-7. Mass stretching the spring

The relation between T and e can be defined as

$$T \propto e$$

$$T = ke$$

The stretching tension overcomes the downward force and makes the mass stable in the rest position.

\therefore Stretching tension = Downward force

$$ke = mg \quad \text{..... Equation 2-14}$$

Consider that the mass is slightly pulled down a further distance x below its equilibrium position.

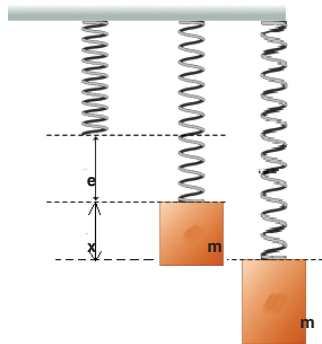

Fig. 2-8. Mass displaced by a stretching external force applied.

The stretching force is equal to the upward tension and is given by $k(x + e)$
So, the resultant force acting on the mass downwards is given by;

$$F = \text{Downward force} - \text{Upward force}$$

$$ma = mg - k(x + e)$$

$$ma = mg - kx - ke \quad \dots\dots\dots \text{Equation 2-15}$$

Substitute equation 2-14 into equation 2-15 to get;

$$ma = -kx$$

$$a = -\frac{k}{m}x \quad \dots\dots\dots \text{Equation 2-16}$$

Where k is the spring constant and m is the mass of the object attached and are all constants. So acceleration is directly proportional to the displacement and acts in opposite direction to extension. So the spring executes S.H.M.

Comparing equation 2-15 and equation 2-16 gives;

$$\omega^2 = \frac{k}{m}$$

$$k = m\omega^2$$

$$\therefore \omega = \sqrt{\frac{k}{m}}$$

$$\Rightarrow \frac{2\pi}{T} = \sqrt{\frac{k}{m}}$$

$$T = 2\pi\sqrt{\frac{m}{k}} \quad \dots\dots\dots \text{Equation 2-17}$$

But from equation 2-14;

$$\frac{m}{k} = \frac{e}{g}$$

$$\text{So } T = 2\pi\sqrt{\frac{e}{g}} \quad \dots\dots\dots \text{Equation 2-18}$$

Form equation 2-17 and 2-18, we conclude that the periodic time of an oscillation of a mass on a spring will depend on extension and the mass tied on it.

EXAMPLE 2.7

When a family of four with a total mass of 200 kg steps into their 1200 kg car, the car's springs get compressed by 3.0 cm.

- (a) What is the spring constant of the car's springs (Fig.2-9), assuming they act as a single spring?
- (b) How far will the car lower if loaded with 300 kg rather than 200 kg?



Fig. 2-9. Image of the car's spring

Solutions:

- (a) The added force of $(200 \text{ kg})(9.8 \text{ m/s}^2) = 1960 \text{ N}$ cause the spring to compress $3.0 \times 10^{-2} \text{ m}$ therefore,

$$k = \frac{F}{x} = \frac{1960}{3.0 \times 10^{-2}} = 6.5 \times 10^4 \text{ N/m}$$

- (b) if the car is now loaded with 300 kg, Hook's law gives;

$$x = \frac{F}{k} = \frac{300 \times 9.8}{6.5 \times 10^4} = 4.5 \times 10^{-2} \text{ m}$$

EXAMPLE 2.8

A light spiral spring is loaded with a mass of 50 g and it extends by 10 cm. Calculate the period of small vertical oscillations.

Solution:

We first find the value of the spring constant

$$k = \frac{mg}{x} = \frac{50 \times 10^{-3} \times 9.8}{10 \times 10^{-2}} = 4.9 \text{ N/m}$$

$$T = 2\pi \sqrt{\frac{m}{k}} = 2\pi \sqrt{\frac{50 \times 10^{-3}}{4.9}} = 0.63 \text{ s}$$

ACTIVITY 2-3: Acceleration due to Gravity

Aim: The aim of this activity is to determine the acceleration due to gravity, g , using mass on spring.

Required materials

1 retort stand, one spiral spring, slotted masses ($5 \times 100\text{g}$), 1 meter rule

Procedure

- (a) Clamp the given spring and a meter rule as shown in the figure above.

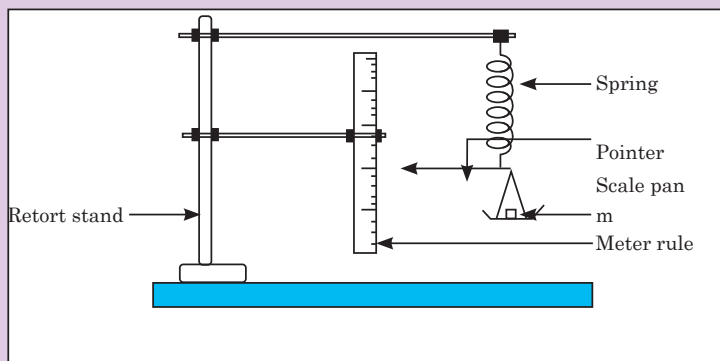

Fig. 2-10. Suspended spring

- (b) Read and record the position of the pointer on the meter rule.
- (c) Place mass m equal to 0.100 kg on the scale pan and record the new position of the pointer on the meter rule.
- (d) Find the extension of the spring x in meters.
- (e) Remove the meter rule.

- (f) Pull the scale pan downwards through a small distance and release it.
- (g) Measure and record the time for 20 oscillations. Find the time T for one oscillation.
- (h) Repeat the procedures (f) and (g) for values of m equal to 0.200 kg, 0.300 kg, 0.400 kg and 0.500 kg.
- (i) Record your results in a suitable table including values of T^2 .
- (j) Plot a graph of T^2 (along the vertical axis) against m (along the horizontal axis).
- (k) Find the slope, s , of the graph.
- (l) Calculate g from $g = \frac{4\pi^2 x}{s}$.

2.2.3 Liquid in a U-tube

Consider a U-shaped tube filled with a liquid. If the liquid on one side of a U-tube is depressed by blowing gently down that side, the level of the liquid will oscillate for a short time about the respective positions O and C before finally coming to rest.

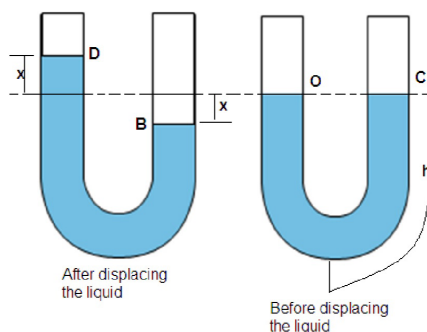

Fig. 2-11. Liquid in a U-tube

As shown in Fig. 2-11, B is x units below the original level C, and D is x units above the original level O. Here x is displacement of the fluid caused by blowing into one arm of the U-tube.

Usually, pressure in liquid is given by;

$$P = \text{density} \times \text{acceleration due to gravity} \times \text{height}$$

$$P = \rho gh \quad \dots\dots\dots \text{Equation 2-19}$$

Excess pressure exerted in the liquid will store some energy to restore the position of the liquid and is given by;

$$P = \text{density} \times \text{acceleration due to gravity} \times \text{Excess height}$$

$$P = \rho \times g \times 2x$$

$$P = 2\rho gx \quad \dots\dots\dots \text{Equation 2-20}$$

Also pressure; $P = \frac{F}{A}$

$\therefore F = PA$

Force on the liquid;

$$F_1 = 2\rho g x A \quad \text{..... Equation 2-21}$$

From the second Newton's law of motion, the resultant force on the liquid is given by;

$$F_2 = ma \quad \text{where } m = \text{mass of the oscillating liquid}$$

As, $Mass = Volume \times density$

$$m = \rho V \text{ and } V = Al \quad l = 2h$$

$\therefore m = 2\rho Ah$

$$F_2 = 2\rho Aha \quad \text{..... Equation 2-22}$$

F_1 and F_2 are equal and opposite to each other;

$$F_2 = -F_1$$

$$2\rho Aha = -2\rho g x A$$

$$a = -\frac{gx}{h} \quad \text{..... Equation 2-23}$$

Where g and h are constant. Comparing equation 2-7 and equation 2-23 gives;

$$\omega^2 = \frac{g}{h}$$

$$\omega = \frac{2\pi}{T} = \sqrt{\frac{g}{h}}$$

$$T = 2\pi \sqrt{\frac{h}{g}} \quad \text{..... Equation 2-24}$$

Equation 2-24 is the expression of the periodic time of S.H.M of the liquid in a U-tube.

Application Activity 2.2

1. A baby in a 'baby bouncer' is a real-life example of a mass-on-spring oscillator. The baby sits in a sling suspended from a stout rubber cord, and can bounce himself up and down if his feet are just in contact with the ground. Suppose a baby of mass 5.0 kg is suspended from a cord with spring constant 500 N m^{-1} . Assume $g = 10 \text{ N kg}^{-1}$.
 - (a) Calculate the initial (equilibrium) extension of the cord.
 - (b) What is the value of angular velocity?
 - (c) The baby is pulled down a further distance, 0.10 m , and released. How long after his release does he pass through equilibrium position?
 - (d) What is the maximum speed of the baby?
 - (e) A simple pendulum has a period of 4.2 s . When it is shortened by 1.0 m the period is only 3.7 s .
 - (f) Calculate the acceleration due to gravity g suggested by the data.
2. A pendulum can only be modelled as a simple harmonic oscillator if the angle over which it oscillates is small. Why is this so?
3. What is the acceleration due to gravity in a region where a simple pendulum having a length 75.000 cm has a period of 1.7357 s ? State the assumptions made.
4. A geologist uses a simple pendulum that has a length of 37.10 cm and a frequency of 0.8190 Hz at a particular location on the Earth. What is the acceleration due to gravity at this location?
5. Find the time taken for a particle moving in S.H.M. from $\frac{1}{2}A$ to $-\frac{1}{2}A$. Given that the period of oscillation is 12 s .
6. A spring is hanging from a support without any object attached to it and its length is 500 mm . An object of mass 250 g is attached to the end of the spring. The length of the spring is now 850 mm .
 - (a) What is the spring constant?

The spring is pulled down 120 mm and then released from rest.
 - (b) Describe the motion of the object attached to the end of the spring.
 - (c) What is the displacement amplitude?

(d) What are the natural frequency of oscillation and period of motion?

Another object of mass 250 g is attached to the end of the spring.

(e) Assuming the spring is in its new equilibrium position, what is the length of the spring?

(f) If the object is set vibrating, what is the ratio of the periods of oscillation for the two situations?

2.3 KINETIC AND POTENTIAL ENERGY OF AN OSCILLATING SYSTEM

Kinetic energy as the energy of a body in motion, change in velocity will also change it as shown on Fig.2-12. Velocity of an oscillating object at any point is given by equation:

$$v = \pm \omega \sqrt{A^2 - x^2}$$

From kinetic energy;

$$K = \frac{1}{2}mv^2 = \frac{1}{2}m^2(A^2 - x^2) \dots\dots\dots \text{Equation 2-25}$$

$$K = \frac{1}{2}m\omega^2 A^2 - \frac{1}{2}m\omega^2 x^2 \dots\dots\dots \text{Equation 2-26}$$

When the particle is in oscillatory motion, work is done against the force trying to restore it. The energy stored to perform this work is called the potential energy.

Force on the particle;

$$F = ma \text{ with } a = \omega^2 x$$

$$\therefore F = m\omega^2 x \dots\dots\dots \text{Equation 2-27}$$

Work done to restore the position of the particle after being displaced by x is given by;

$$\text{Work done} = \text{Average force} \times \text{Distance}$$

Note that there is no work done when displacement is zero.

$$\text{Work done} = \frac{F+0}{2} \times \text{Displacement}$$

$$u = \text{Work done} = \frac{1}{2}Fx \quad \dots\dots\dots \text{Equation 2-28}$$

Substitute equation 2-32 into equation 2-33 to get;

$$u = \frac{1}{2}m\omega^2x^2 \quad \dots\dots\dots \text{Equation 2-29}$$

2.4 ENERGY CHANGES AND ENERGY CONSERVATION IN AN OSCILLATING SYSTEM

In an oscillation, there is a constant interchange between the kinetic and potential forms and if the system does no work against resistive force its total energy is constant. Fig.2-12 illustrates the variation of potential energy and kinetic energy with displacement x .

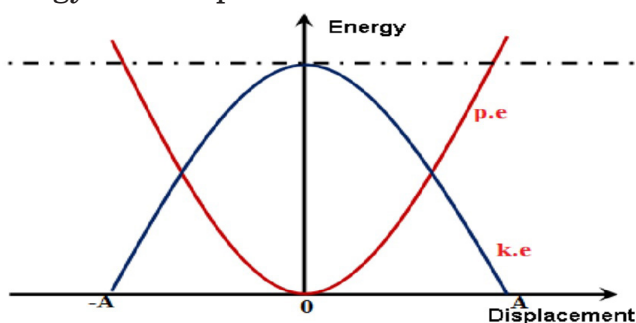

Fig. 2-12. Variation of potential and kinetic energy of an oscillating system

Substituting equation for sinusoidal displacement into equation 2-29 and equation 2-30 gives;

$$K = \frac{1}{2}m\omega^2A^2 - \frac{1}{2}m\omega^2A^2 \sin^2 \omega t$$

$$K = \frac{1}{2}m\omega^2A^2(1 - \sin^2\omega t) \quad \text{But } 1 - \sin^2 \omega t = \cos^2 \omega t$$

$$K = \frac{1}{2} m\omega^2A^2 \cos^2 \omega t \quad \dots\dots\dots \text{Equation 2-30}$$

$$u = \frac{1}{2} m\omega^2 A^2 \sin^2\omega t \quad \dots\dots\dots \text{Equation 2-31}$$

The total energy of an oscillating system using equations 2.35 and 2.36 is given by;

$$\text{Total energy. } E = K + u \quad \dots\dots\dots \text{Equation 2-32}$$

$$E = \frac{1}{2} m\omega^2 A^2 - \frac{1}{2} m\omega^2 x^2 + \frac{1}{2} m\omega^2 x^2$$

$$E = \frac{1}{2} m\omega^2 A^2 \quad \dots\dots\dots \text{Equation 2-33}$$

The equation 2-33 of total energy indicates that this energy is constant and

is independent of displacement x . Since the total energy of an oscillating particle is constant, it means that potential energy and kinetic energy vary in such a way that total energy is conserved.

Also substituting equation 2-30 and equation 2-31 into equation 2-32 will give an expression for the total energy of an oscillating system which is independent of time taken.

$$E = \frac{1}{2} m\omega^2 A^2 \cos^2 \omega t + \frac{1}{2} m\omega^2 A^2 \sin^2 \omega t$$

$$E = \frac{1}{2} m\omega^2 A^2 (\cos^2 \omega t + \sin^2 \omega t)$$

$$\therefore E = \frac{1}{2} m\omega^2 A^2$$

Fig.2-15 illustrates the variation of energy of an oscillating system with time.

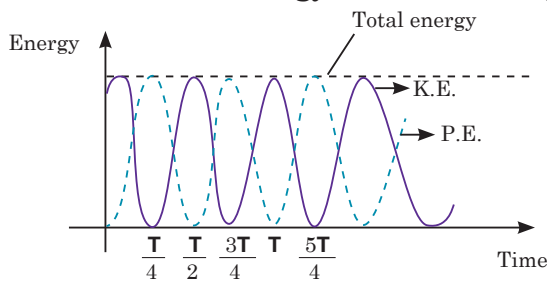

Fig. 2-13. Variation of energy of an oscillating system with time

EXAMPLE 2.9

A 0.500 kg cart connected to a light spring for which the force constant is 20.0 N/m oscillates on a horizontal, frictionless air track.

- Calculate the total energy of the system and the maximum speed of the cart if the amplitude of the motion is 3.00 cm.
- What is the velocity of the cart when the position is 2.00 cm?
- Compute the kinetic and potential energies of the system when the position is 2.00 cm.

Solution:

- Using equation 2-55

$$E = \frac{1}{2} m\omega^2 A^2$$

$$E = \frac{1}{2} \times 20 \times (3 \times 10^{-2})^2 = 9 \times 10^{-3} \text{ J}$$

Maximum K.E. energy is obtained when the cart is

located at $x = 0$, and potential energy $u = 0$.

$$\therefore K = \frac{1}{2}mv_{\max}^2$$

$$(b) \quad v_{\max} = \sqrt{\frac{2E_{\max}}{m}} = \sqrt{\frac{2 \times 9 \times 10^{-3} \text{ J}}{0.5 \text{ kg}}} = 0.19 \text{ m/s}$$

$$v = \pm \sqrt{\frac{k}{m}(A^2 - x^2)} = \pm \sqrt{\frac{20}{0.5}(0.03^2 - 0.02^2)} = \pm 0.141 \text{ m/s}$$

The positive and negative signs indicate that the cart could be moving to either the right or the left at this instant.

$$(c) \quad K = \frac{1}{2}mv^2 = \frac{1}{2} \times 0.5 \times 0.141^2 = 5.0 \times 10^{-3} \text{ J}$$

$$u = \frac{1}{2}kx^2 = \frac{1}{2} \times 20 \times 0.02^2 = 4.0 \times 10^{-3} \text{ J}$$

Application Activity 2.3

1. The graph in fig. below shows the variation with displacement of the kinetic energy with displacement of a particle of mass 0.40 kg performing SHM.

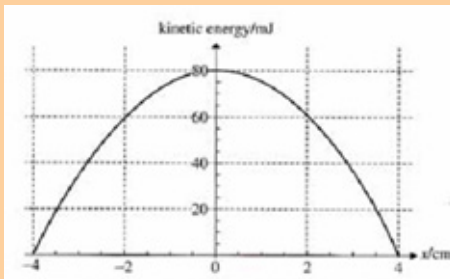

Use the graph to determine:

- i. The total energy of the particle.
- ii. The maximum speed of the particle.
- iii. The amplitude of the motion.
- iv. The potential energy when the displacement is 2.0 cm.
- v. The period of the motion.

2. A 0.500-kg mass is vibrating in a system in which the restoring constant is 100 N/m; the amplitude of vibration is 0.200 m.

Find

- The PE and KE when $x = 0.100$ m
- The mechanical energy of the system
- The maximum velocity

2.5 SUPERPOSITION OF HARMONICS OF SAME FREQUENCY AND SAME DIRECTION

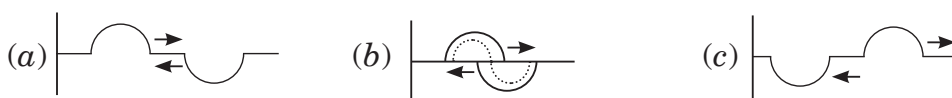

Consider two simple harmonic oscillations which interfere to produce a displacement x of the particle along same line. Suppose that both have the same frequency. The displacement time functions of respective motions are given by equations 2-39 and 2-40 with A_1 and A_2 being the amplitude of individual displacements (x_1 and x_2) and α_1 and α_2 as their respective phase angles;

$$x_1 = A_1 \sin(\omega t + \alpha_1) \quad \dots\dots\dots \text{Equation 2-34}$$

$$x_2 = A_2 \sin(\omega t + \alpha_2) \quad \dots\dots\dots \text{Equation 2-35}$$

After superposition or interference, the displacement of the resultant harmonic motion is;

$$x = x_1 + x_2$$

$$x = A_1 \sin(\omega t + \alpha_1) + A_2 \sin(\omega t + \alpha_2)$$

$$x = \sin \omega t (A_1 \cos \alpha_1 + A_2 \cos \alpha_2) + \cos \omega t (A_1 \sin \alpha_1 + A_2 \sin \alpha_2) \quad \dots \text{Equation 2-36}$$

Assume that; $\begin{cases} A \cos \alpha = A_1 \cos \alpha_1 + A_2 \cos \alpha_2 \\ A \sin \alpha = A_1 \sin \alpha_1 + A_2 \sin \alpha_2 \end{cases} \quad \dots\dots\dots \text{Equation 2-37}$

Substitute equation 2-37 into equation 2-36 to give;

$$x = A \sin \omega t \cos \alpha + A \cos \omega t \sin \alpha$$

$$x = A \sin (\omega t + \alpha) \dots\dots\dots \text{Equation 2-38}$$

Squaring and adding expressions of equation 2-38 gives the amplitude A of the resultant displacement;

$$A^2 = A_1^2 + A_2^2 + 2A_1A_2 \cos (\alpha_1 - \alpha_2) \dots\dots\dots \text{Equation 2-39}$$

If the two harmonic oscillations are in phase;

$$\alpha_1 = \alpha_2$$

$$\therefore A^2 = A_1^2 + A_2^2 + 2A_1A_2$$

$$\Rightarrow A = A_1 + A_2 \dots\dots\dots \text{Equation 2-40}$$

Equation 2-40 is the equation of resultant amplitude A in terms of amplitudes of individual displacements.

Dividing expressions of equation 2-37 gives the phase α of the resultant displacement;

$$\tan \alpha = \frac{A_1 \sin \alpha_1 + A_2 \sin \alpha_2}{A_1 \cos \alpha_1 + A_2 \cos \alpha_2} \dots\dots\dots \text{Equation 2-41}$$

QUESTIONS

1. Give at least 2 examples of the applications of superposition in real life.
2. Derive the expression for the resultant displacement of two oscillations of the same frequency but acting in opposite directions.

END OF UNIT ASSESSMENT

1. An object oscillates with simple harmonic motion along the x axis. Its position varies with time according to the equation $x = (4.0 \text{ m}) \cos \left(\pi t + \frac{\pi}{4} \right)$ where t is in seconds and the angles in the parentheses are in radians.
 - (a) Determine the amplitude, frequency, and period of the motion.
 - (b) Calculate the velocity and acceleration of the object at any time t .
 - (c) Using the results of part (b), determine the position, velocity, and acceleration of the object at $t = 1.0 \text{ s}$.
 - (d) Determine the maximum speed and maximum acceleration of the object.
 - (e) Find the displacement of the object between $t = 0 \text{ s}$ and $t = 1.0 \text{ s}$.

2. A 200 g block connected to a light spring for which the force constant is 5.00 N/m is free to oscillate on a horizontal, frictionless surface. The block is displaced by 5.00 cm from equilibrium and released from rest, as in Fig.2-15.

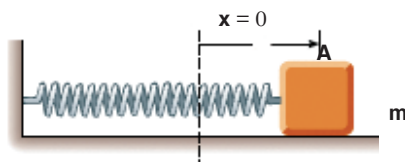

Fig. 2-14. Mass on the spring

- (a) Find the period of its motion.
- (b) Determine the maximum speed of the block.
- (c) What is the maximum acceleration of the block?
- (d) Express the position, speed, and acceleration as functions of time.
3. (a) A 10 N weight extends a spring by 5 cm. Another 10 N weight is added, and the spring extends another 5 cm. What is the spring constant of the spring?
- (b) A pendulum oscillates with a frequency of 0.5 Hz. What is the length of the pendulum?
4. Christian Huygens (1629–1695), the greatest clockmaker in history, suggested that an international unit of length could be defined as the length of a simple pendulum having a period of exactly 1 s. How much shorter would our length unit be had his suggestion been followed?
5. A simple pendulum is suspended from the ceiling of a stationary elevator, and the period is determined. Describe the changes, if any, in the period when the elevator
- (a) accelerates upward,
- (b) accelerates downward, and
- (c) moves with constant velocity.
6. Imagine that a pendulum is hanging from the ceiling of a car. As the car coasts freely down a hill, is the equilibrium position of the pendulum vertical? Does the period of oscillation differ from that in a stationary car?
7. What is the acceleration due to gravity in a region where a simple pendulum having a length 75.000 cm has a period of 1.7357 s?

UNIT SUMMARY

Simple Harmonic Motion: Any motion that repeats itself in equal time intervals is called periodic motion with the force F acting on an object directly proportional to the displacement x from a fixed point and is always towards this point.

Periodic Time; is the time taken by the particle to complete one oscillation.

Frequency is defined as number of oscillations occur in one second $f = \frac{1}{T}$.

Amplitude is the maximum displacement of the particle from its resting position.

Angular velocity (ω): is the rate of change of angular displacement with time.

$$\omega = \frac{2\pi}{T}$$

Linear velocity (v): is the rate of change of linear displacement with time.

$$v = \pm\omega\sqrt{A^2 - x^2}$$

Linear acceleration of a particle is the rate of change of linear velocity of that particle with time.

$$a = \omega^2x$$

The **equation of simple harmonic** motion is derived based on the conditions necessary for simple harmonic equation;

$$\frac{d^2x}{dt^2} + \omega^2x = 0$$

Solution of a Simple Harmonic motion equation;

$$x(t) = A \sin (\omega t + \Phi)$$

A simple pendulum executes S.H.M and its period is given by;

$$T = 2\pi \sqrt{\frac{L}{g}}$$

The **extension of the spiral spring** (caused by attached mass) which obeys Hooke's law is directly proportional to the extending tension. The periodic time of oscillation caused by releasing the mass is given by;

$$T = 2\pi \sqrt{\frac{m}{k}}$$

or

$$T = 2\pi \sqrt{\frac{e}{g}}$$

If a U-shaped tube is filled with a liquid and liquid on one side of a U-tube is depressed by blowing gently down that side, the liquid will oscillate and execute simple harmonic motion with period given by;

$$T = 2\pi \sqrt{\frac{h}{g}}$$

The total energy of any oscillating object is always constant and is given by;

$$E = \frac{1}{2} m\omega^2 A^2$$

The potential energy of the oscillating object is given by;

$$U = \frac{1}{2} m\omega^2 x^2$$

Kinetic energy of an oscillating object is given by;

$$K = \frac{1}{2} m\omega^2 A^2 - \frac{1}{2} m\omega^2 x^2$$

Superposition of harmonic oscillations always give the displacement of the resultant equal to the sum of individual displacements.

UNIT
3

FORCED OSCILLATIONS AND RESONANCE OF A SYSTEM



Key unit competence: Analyze the effects of forced oscillations on systems..

Unit Objectives:

By the end of this unit I will be able to;

- ◇ Explain the concept of oscillating systems and relate it to the real life situations.
- ◇ Solve equations of different types of damped oscillations and derive the expression for displacement for each.
- ◇ explain resonance, state its conditions and explain its applications in everyday life.

Introductory Activity

Comment on the following situations by giving clear reasons on each;

- A guitar string stops oscillating a few seconds after being plucked.
- To keep a child moving on a swing, you must keep pushing.

3.0 INTRODUCTION

In the conventional classification of oscillations by their mode of excitation, oscillations are called forced if an oscillator is subjected to an external periodic influence whose effect on the system can be expressed by a separate term, a periodic function of the time, in the differential equation of motion. We are interested in the response of the system to the periodic external force. The behaviour of oscillatory systems under periodic external forces is one of the most important topics in the theory of oscillations. A noteworthy distinctive characteristic of forced oscillations is the phenomenon of resonance, in which a small periodic disturbing force can produce an extraordinarily large response in the oscillator. Resonance is found everywhere in physics and thus, a basic understanding of this fundamental problem is required.

3.1 DAMPED OSCILLATIONS.

Unless maintained by some source of energy, the amplitude of vibration of any oscillatory motion becomes progressively smaller and the motion is said to be **damped**. The majority of the oscillatory systems that we encounter in everyday life suffer this sort of irreversible energy loss while they are in motion due to frictional or viscous heat generation generally. We therefore expect oscillations in such systems to eventually be damped.

Damping is the gradual decrease of amplitude of an oscillating system due to presence of dissipative forces. As work is being done against the dissipating force, energy is lost. Since energy is proportional to the amplitude, the amplitude decreases exponentially with time.

ACTIVITY 3-1: Resonance

Clearly observe the figure below and answer the questions that follow:

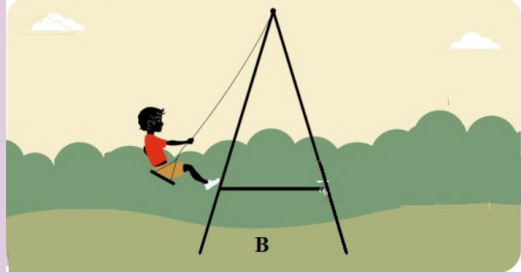
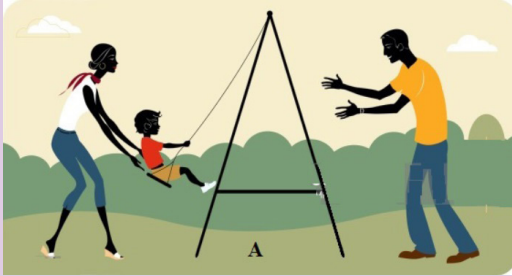

- How is figure A different from B?
- What do you think the kid is doing?
- Assume that the man and woman shown are the kid's father and mother. What do you think they are doing?
- Explain the oscillations in both cases.
- Compare the two oscillations.
- Depending on the definition of damping given above, how do you relate it with the above scenarios?
- Make a clear conclusion.

In everyday life we experience some damped oscillations like:

- Damping due to the eddy current produced in the copper plate

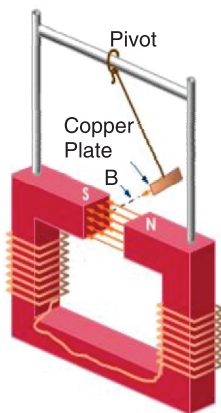

Fig.3-1; Damping due to eddy current

- Damping due to the viscosity of the liquid

3.2 EQUATION OF DAMPED OSCILLATIONS

Consider a body of mass m attached to one end of a horizontal spring, the other end of which is attached to a fixed point. The body slides back and forth along a straight line, which we take as x -axis of a system of Cartesian coordinates and is subjected to forces all acting in x -direction (they may be positive or negative). The motion equations for constant mass are based on Newton's second law which can be expressed in terms of derivatives. In all derivations assume that m is the mass of an oscillating object, b is the damping constant and k is the spring constant.

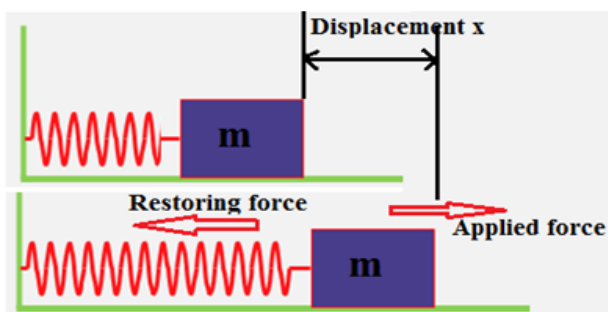

Fig.3-2; Mass attached with the spring

$$F_{net\ external} = ma$$

$$\Rightarrow F_{net\ external} = m \frac{d^2x}{dt^2}$$

Where x is displacement. The force that causes damping is directly proportional to the speed of oscillation. i.e.

$$F_{damping} \propto v$$

$$F_{damping} \propto \frac{dx}{dt}$$

$$F_{damping} = -b \frac{dx}{dt} \quad \dots\dots\dots \text{Equation 3-1}$$

Where b is the damping constant and the negative sign means that damping force always opposes the direction of motion of the mass.

The spring itself stores the energy that is used to restore the position of the mass once released after being slightly displaced. The restoring force of the spring is directly proportional to the displacement.

$$F_{restoring} \propto x$$

$$F_{restoring} = -kx$$

Where k is the spring constant and the negative sign means that the restoring force opposes the direction of motion of the mass. With this restoring force and the resisting force of the spring, the resultant force on the mass is;

$$F_{net\ external} = F_{damping} + F_{restoring}$$

$$m \frac{d^2x}{dt^2} = -b \frac{dx}{dt} - kx$$

$$m \frac{d^2x}{dt^2} + b \frac{dx}{dt} + kx = 0 \quad \dots\dots\dots \text{Equation 3-2}$$

Equation 3.2 is the differential equation of damping.

3.3 THE SOLUTION OF EQUATION OF DAMPING

In terms of derivatives, the equation of damped oscillation is given by

$$m\ddot{x} + 2\delta m\dot{x} + kx = 0 \quad \text{or} \quad \ddot{x} + 2\delta\dot{x} + \omega_0^2 x = 0 \quad \dots\dots\dots \text{Equation 3-3}$$

where

- $\delta = \frac{b}{2m}$ is damping constant which depends on the kind of liquid the mass is in and the shape of the mass.

- $\gamma = \frac{\delta}{\omega_0} = \frac{b}{2\sqrt{km}}$ constant called damping ratio

- $\omega_0 = \sqrt{\frac{k}{m}}$ represents the angular frequency in the absence of a retarding force (the undamped oscillator) and is called the natural frequency of the system.

The equ.3-3 is a *second-order differential equation*. The solution of this equation is

$$x = A_0 e^{-\delta t} \cos(\omega t + \varphi) \quad \dots\dots\dots \text{Equation 3-4}$$

Where

- $\omega^2 = \omega_0^2 - \delta^2$ is the angular speed of damped oscillations

- A_0 is the initial amplitude of undamped oscillations

- $A = A_0 e^{-\delta t}$ is the amplitude of damped oscillations

The period of damped oscillations:

$$T = \frac{2\pi}{\omega} = \frac{2\pi}{\sqrt{\omega_0^2 - \delta^2}} = \frac{2\pi}{\omega \sqrt{1 - \left(\frac{\delta}{\omega_0}\right)^2}} = \frac{2\pi}{\omega \sqrt{1 - \gamma^2}} \quad \text{..... Equation 3-5}$$

Therefore $T = \frac{T_0}{\sqrt{1 - \gamma^2}}$ where T_0 is the period of free oscillationEquation 3-6

We see that when the retarding force is small, the oscillatory character of the motion is preserved but the amplitude decreases in time, with the result that the motion ultimately ceases. Any system that behaves in this way is known as a **damped oscillator**.

Figure 3-3 shows the position as a function of time for an object oscillating in the presence of a retarding force.

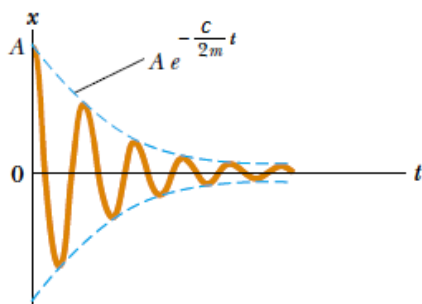

Fig.3. 3 Graph of position versus time for a damped oscillator (underdamped oscillation). The dashed blue lines in Fig.3.3, which define the **envelope of the oscillatory curve**, represent the exponential factor in Equation 3-4. This envelope shows that the amplitude decays exponentially with time.

3.4 TYPES OF DAMPED OSCILLATION

Let consider differential equation of damped oscillation $\ddot{x} + 2\delta\dot{x} + \omega_0^2x = 0$

The quadratic equation known as the *characteristic equation* of the differential Eq. (3-3), is

$$\lambda^2 + 2\delta\lambda + \omega_0^2 = 0 \quad \text{..... Equation 3-7}$$

where $\delta = \frac{b}{2m}$ and $\omega_0 = \sqrt{\frac{k}{m}}$ Equation 3-8

The equation 3-7 is obtained by substituting $x = e^{\lambda t}$

The roots of the characteristic equation Eq. (3-7) are:

$$\lambda_1 = -\delta + \sqrt{\delta^2 - \omega_o^2} \text{ and } \lambda_2 = -\delta - \sqrt{\delta^2 - \omega_o^2} \quad \text{..... Equation 3-9}$$

- The roots λ_1 and λ_2 are called **natural frequencies**, measured in neper per second (Np/s), because they are associated with the natural response of the circuit;
- ω_o is known as the **resonant frequency** or strictly as the *undamped natural frequency*, expressed in radians per second (*rad / s*);
- δ is the **neper frequency** or the **damping factor**, expressed in neper per second.

In the simplest case, when $b = 0$, this Equation reduces to that of a simple *harmonic motion*, as expected, and the system oscillate sinusoidally in time. This is equivalent to removal of all damping in the mechanical oscillator. When b is small, a situation analogous to light damping in the mechanical oscillator,

From Eq. (3-14), we can infer that there are three types of solutions; depending on whether the roots of the associated characteristic equation are:

- (a) real and distinct , when $\delta > \omega_o$,
- (b) equal when $\delta = \omega_o$, or
- (c) complex conjugate if $\delta < \omega_o$.

These cases are respectively classified as **overdamped**, **critically damped**, and **oscillatory damped** (or, in electrical problems, **underdamped**) as shown in fig.3.4.

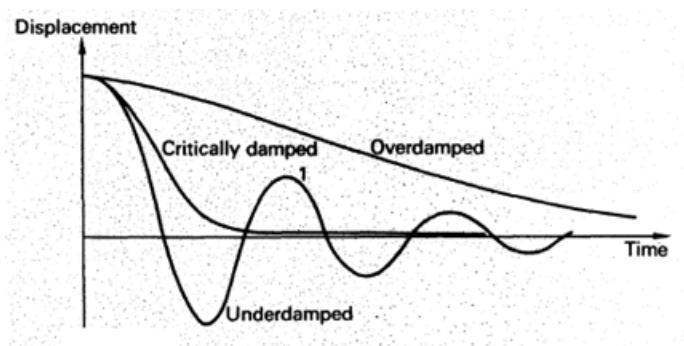

Fig.3. 4 Types of damped oscillation

Let us consider these cases separately:

3.4.1 Overdamped or Heavy damping

Overdamped or Heavy damping is also called excessive damped oscillation and occur when $\delta > \omega_0$ i.e. $\gamma > 1$

From Eq. (3-9) , $\delta > \omega_0$, When this happens, both roots λ_1 and λ_2 are negative and real.

The solution of equ. 3-8 is $x = A_1e^{\lambda_1 t} + A_2e^{\lambda_2 t}$ Equation 3-10

where the constants A_1 and A_2 are determined from the initial values $x(0)$. This is system decays and approaches zero as t increases. The amplitude will gradually decrease and the oscillations will die out. An oscillation which dies away is an example of a **transient motion**.

The system returns (exponentially decays) to equilibrium without oscillating. Larger values of the damping ratio δ return to equilibrium more slowly.

3.4.2 Critically Damped oscillation

When $\delta = \omega_0$ i.e. $\gamma = 1$ there is a double root, which is real $\lambda_1 = \lambda_2 = -\delta$. The solution is then:

$$x(t) = (A_1 + A_2 t)e^{-\delta t} \quad \text{..... Equation 3-11}$$

A typical critically damped oscillation is shown in Fig. 3.4). A critically damped system converges to zero as fast as possible without oscillating.

An example of critical damping is the door closer seen on many hinged doors in public buildings. An over-damped door-closer will take longer to close than a critically damped door would.

Examples of Critical damping

(a) Shock Absorber

It critically damps the suspension of the vehicle and so resists the setting up of vibrations which could make control difficult or cause damage. The viscous force exerted by the liquid contributes to this resistive force.

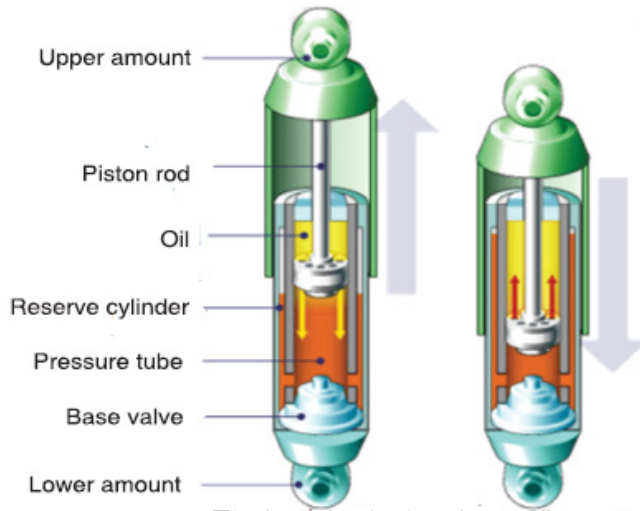

Fig 3.5: shock absorber
Extension cycle Compression cycle

(b) Electrical Meters They are critically damped (i.e. dead-beat) oscillators so that the pointer moves quickly to the correct position without oscillation.

3.4.3 Under-damped Case ($\delta < \omega_0$ i.e. $0 < \gamma < 1$)

Under-damped oscillation is also called a lightly damped oscillation and occurs when $\delta < \omega_0$ i.e. $0 < \gamma < 1$

For $\delta < \omega_0$, The roots are complex and may be written as

$$\lambda_1 = -\delta + \sqrt{\delta^2 - \omega_0^2} = -\delta + \sqrt{-(\omega_0^2 - \delta^2)} = -\delta + j\omega_d$$

and

$$\lambda_2 = -\delta - \sqrt{\delta^2 - \omega_0^2} = -\delta - \sqrt{-(\omega_0^2 - \delta^2)} = -\delta - j\omega_d$$

where $j = \sqrt{-1}$ and $\omega_d = \sqrt{\omega_0^2 - \delta^2}$, which is called the damping frequency or damped natural frequency while ω_0 is often called the undamped natural frequency.

The solution of equ.3-8 is then $x(t) = A_3 e^{-(\delta - j\omega_d)t} + A_4 e^{-(\delta + j\omega_d)t} = e^{-\delta t} (A_3 e^{j\omega_d t} + A_4 e^{-j\omega_d t})$

which can be rewritten, using Euler's relations, $\begin{cases} e^{j\varphi} = \cos \varphi + j \sin \varphi \\ e^{-j\varphi} = \cos \varphi - j \sin \varphi \end{cases}$...Equation 3-12

As $x(t) = e^{-\delta t} (A_1 \cos \omega_d t + A_2 \sin \omega_d t)$ Equation 3-13

Equation 3-13 has the alternate form: $x(t) = Ae^{-\delta t} \sin(\omega_d t + \varphi)$ Equation 3-14

Where $\begin{cases} A = \sqrt{A_1^2 + A_2^2} \\ \tan \varphi = \frac{A_2}{A_1} \end{cases}$

The system oscillates with the amplitude gradually (slowly) decreasing to zero. In this situation, the system will oscillate at the natural damped frequency ω_d , which is a function of the natural frequency and the damping ratio. This system stops after one or two oscillations.

To continue the analogy, an underdamped door closer would close quickly, but would hit the door frame with significant velocity, or would oscillate in the case of a swinging door. Fig.3.4 depicts a typical underdamped response.

Examples of slightly damped oscillations include

Acoustics

(i) A percussion musical instrument (e.g. a drum) gives out a note whose intensity decreases with time. (slightly damped oscillations due to air resistance)

(ii) The paper cone of a loud speaker vibrates, but is heavily damped so as to lose energy (sound energy) to the surrounding air.

Plotting equations for damped oscillation on the same amplitude-time axes gives the general curve for damping oscillation as shown on Fig.3-6.

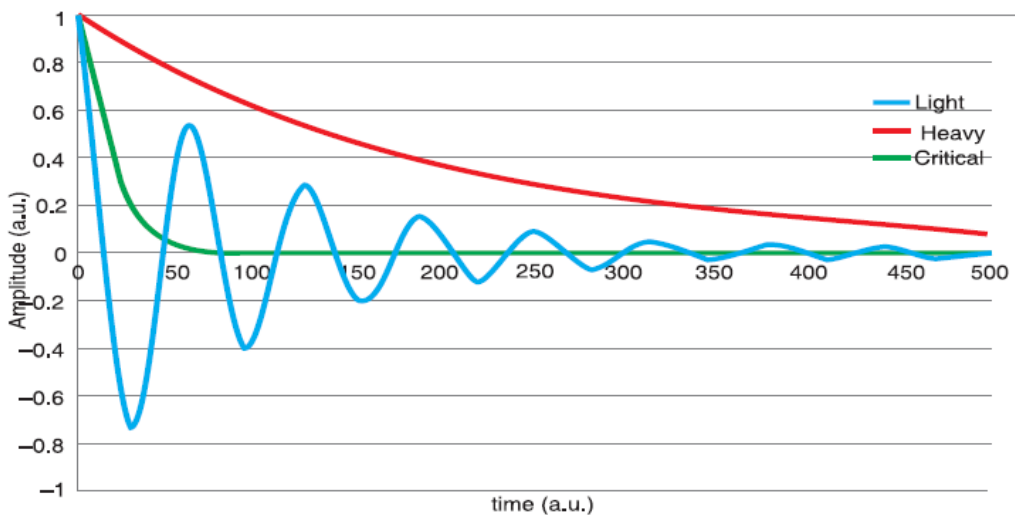

Fig. 3. 6 Damping oscillation curves

Undamped oscillation (free oscillations): $\delta = 0$

If the oscillating system is isolated (i.e. if no energy is being added to or taken away from the system) the oscillations are called **free oscillations**. The system oscillates at its natural resonant frequency ω_0 . Free Oscillations can occur whenever a restoring force capable of transforming potential energy (PE) to kinetic energy (KE) and vice versa is present. In a free oscillation, since the sum of the PE and KE cannot increase, the PE must be largest at the extreme points of the oscillation where the KE is zero.

Examples

- Liquid sloshing mode - the restoring forces are due to gravity.
- A vibrating metal plate - elastic restoring forces.
- Stretched string - the restoring force is provided by tension in the string.

In each of these three examples all the oscillating particles together formed a **standing wave pattern**.

ACTIVITY 3-2 Damping Oscillation

A mass and spring system was set up with three masses of 100g and radius 2.5 cm. The oscillator (masses) was displaced by 3 cm, released and the time was measured for the oscillator to come to rest. After this, pieces of circular cards were inserted between two of the masses and the experiment was carried out again. Analyse the results obtained as tabulated in table 3-1.

Table 3-1; Experimental Data

Radius of card (cm)	Time taken for oscillator to come to rest (s)			Mean time (s)	Area of Oscillator (m ²)	Additional Area (m ²)	% of Undamped time to come to rest
0.0	259	248	254			-----	-----
6.0	134	131	143				
7.0	116	115	111				
8.0	92	83	83				
9.0	65	68	68				
10.0	58	57	53				

Analysis

- Calculate mean value for the time taken for the oscillator to come to rest for each radius of card.

- What is the uncertainty in the time taken to stop when the radius is 6 cm?
- Calculate this as a percentage of the mean value.
- What is the uncertainty in the time taken to stop when the radius is 8 cm?
- Calculate this as a percentage of the shortest time measurement at this radius.
- What is the uncertainty in the time taken to stop when the radius is 10 cm?
- Calculate this as a percentage of the longest time measurement at this radius.
- What type of error is responsible for the difference in the value of the time taken to come to rest?
- Calculate the area of the oscillator using $A = \pi r^2$. Write these values in the column provided.
- What is the precision in the radius of card measurements?
- Calculate the percentage uncertainty in the 7.0 cm measurement.
- What will be the percentage uncertainty in the value of the area?
- Write down the upper and lower limits of the area.
- Plot a graph of radius of Oscillator (on the y axis) against time taken to come to rest.
- Describe the graph you have plotted.
- What does your graph suggest about the relationship between the two variables?
- Plot a graph of area of Oscillator (on the y axis) against time taken to come to rest.
- Describe the graph you have plotted.
- What does your graph suggest about the relationship between these two variables?
- Complete the final columns of the table by calculating the additional area each card adds to the oscillator and the time period as a percentage of the undamped time taken to come to rest.
- Do you notice any patterns or trends?
- Plot a graph of additional area (y axis) against percentage of undamped time taken to come to rest.
- How are these variables linked?
- Theory states that damping will not affect the time period of the SHM system. How could you prove this using the experimental set up described above?

3.5 NATURAL FREQUENCY OF A VIBRATION AND FORCED OSCILLATION.

The natural frequency of an object is the frequency of oscillation when released. e.g. a pendulum. A forced oscillation is where an object is subjected to a force that causes it to oscillate at a different frequency than its natural frequency. e.g. holding the pendulum bob in your hand and moving it along its path either more slowly or more rapidly than its natural swing. Examples on forced oscillation include:

A: Barton's Pendulum

The oscillation of one pendulum by application of external periodic force causes the other pendulums to oscillate as well due to the transfer of energy through the suspension string. The pendulum having the same pendulum length and pendulum bob mass will have the same natural frequency as the original oscillating pendulum and will oscillate at maximum amplitude due to being driven to oscillate at its natural frequency causing resonance to occur.

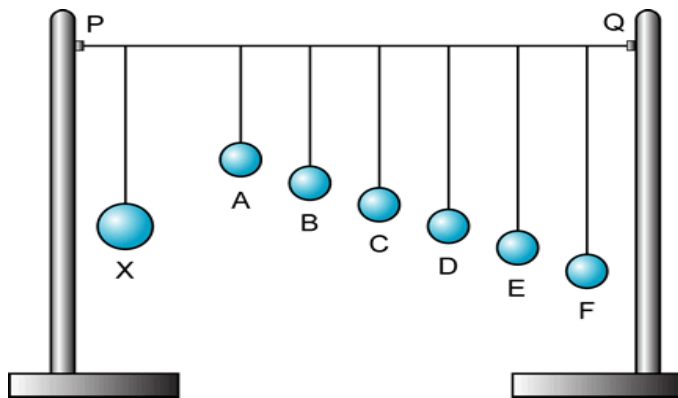

Fig.3-7; Barton's Pendulum

B: Hacksaw blade oscillator

This is another example of resonance in a driven system. If the period of oscillation of the driver is changed by increasing the length of thread supporting the moving mass, the hacksaw blade will vibrate at a different rate. If we get the driving frequency right the slave will reach the resonant frequency and vibrate widely. Moving the masses on the blade will have a similar effect.

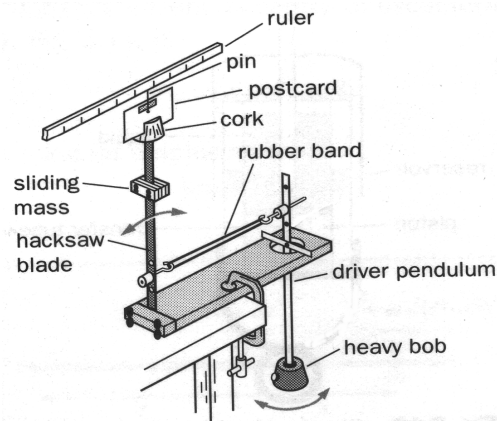

Fig.3-8; Hacksaw blade oscillator

3.6 EQUATION OF FORCED OSCILLATION AND ITS SOLUTION

The mechanical energy of a damped oscillator decreases in time as a result of the resistive force. It is possible to compensate for this energy decrease by applying an external force that does positive work on the system. At any instant, energy can be transferred into the system by an applied force that acts in the direction of motion of the oscillator.

For example, a child on a swing (see Fig.3.5) can be kept in motion by appropriately timed “pushes.” The amplitude of motion remains constant if the energy input per cycle of motion exactly equals the decrease in mechanical energy in each cycle that results from resistive forces.

When a vibrating system is set into motion, it vibrates at its natural frequency f_o , the resistive force decrease the amplitude because there is a loss of energy. To stop the decrease of amplitude you must give an external energy to the system. The system that gives energy is called **excitatory** and one receiving is called **resonator**. The resonator is forced to oscillate at the frequency f_e the external force and oscillation is forced.



Fig.3. 9 A child on the string must be pushed to maintain the oscillation. A person pushing a child has to supply energy when the child is in need of it

Symbolically, it is designated by a dashpot, as shown in Fig. below

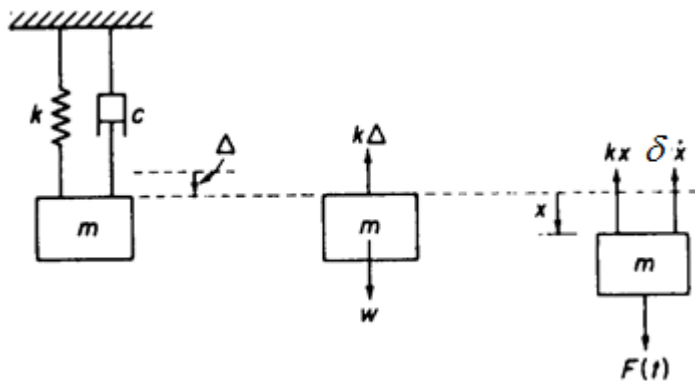

Fig.3. 10 Free body diagram for forced oscillation

From the free body diagram, the equation of motion is seen to be

$$m\ddot{x} + 2\delta m\dot{x} + kx = F_{ext}(t) \quad \text{..... Equation 3-15}$$

Where

- $F_{ext}(t) = F_{max} \cos \omega_e t$ is the external force Equation 3-16
- F_{max} is maximum external force
- ω_e is angular speed of external force

The solution of this equation has two parts.

- If $F(t) = 0$, we have the homogeneous differential equation whose solution corresponds physically to that of **free-damped vibration**:

$$m\ddot{x} + 2\delta m\dot{x} + kx = 0 \quad \text{..... Equation 3-17}$$

The general solution is given by the equation: $x(t) = Ae^{\lambda_1 t} + Be^{\lambda_2 t}$ Equation 3-18

where A and B are constants to be evaluated from the initial conditions $x(0)$ and $\dot{x}(0)$ and δ is a constant.

- If the external force is periodic force: $F_{ext}(t) = F_{max} \cos \omega_e t$

where F_{max} is maximum external force and ω_e is angular speed of external force

$$m\ddot{x} + 2\delta m\dot{x} + kx = F_{\max} \cos \omega_e t \quad \text{or} \quad \ddot{x} + 2\delta\dot{x} + \omega_0^2 x = \frac{F_{\max}}{m} \cos \omega_e t$$

$$\ddot{x} + 2\delta\dot{x} + \omega_0^2 x = F_o \cos \omega_e t$$

$$\text{Where } F_o = \frac{F_{\max}}{m} \quad \dots\dots\dots \text{Equation 3-19}$$

The solution of this equation is given by $x = A \cos(\omega_e t + \varphi)$ Equation 3-20

because the resonant oscillation and exciting (stimulant) have the same frequency.

Where A is the amplitude of forced oscillation and phase difference

$$\left\{ \begin{array}{l} A = \frac{F_o}{\sqrt{(\omega_0^2 - \omega_e^2)^2 + 4\delta^2 \omega_e^2}} \\ \tan \varphi = \frac{2\delta \omega_e}{\omega_e^2 - \omega_0^2} \end{array} \right. \quad \dots\dots\dots \text{Equation 3-21}$$

Example

1. A 2.00 kg object attached to a spring moves without friction and is driven by an external force given by $F = (3.00 \text{ N}) \sin 2\pi t$. If the force constant of the spring is $k = 20.0 \text{ N/m}$, determine

- a) the period
- b) the amplitude of the motion.

Answer

(a) $\omega = \frac{2\pi}{T} = 2\pi \text{ rad/s}$ so $T = 1.00 \text{ s}$

(b) In this case, $\omega_o = \sqrt{\frac{k}{m}} = \sqrt{\frac{20.0 \text{ N/m}}{2.00 \text{ kg}}} = 3.16 \text{ rad/s}$

The equation for the amplitude of a driven oscillator, with $c = 0$, gives

$$A = \frac{F_{\max}}{m\sqrt{(\omega_0^2 - \omega_e^2)^2 + 4\delta^2 \omega_e^2}} = \frac{F_{\max}}{m(\omega_0^2 - \omega_e^2)} = \frac{3.00}{2.00(4\pi^2 - 3.16^2)} = 5.05 \text{ cm}$$

3.7. VARIATION OF FORCED FREQUENCY ON GRAPH AT AMPLITUDE CLOSE TO NATURAL FREQUENCY OF VIBRATION.

If an oscillating object is made to perform forced oscillations, closer is the frequency of force applied to the natural frequency, larger is the oscillation. However the amplitude rises and falls as the object will be assisted to oscillate for a short time and then the forces will oppose its motion for a short time. The graph shows the variation of the amplitude of the oscillations with time.

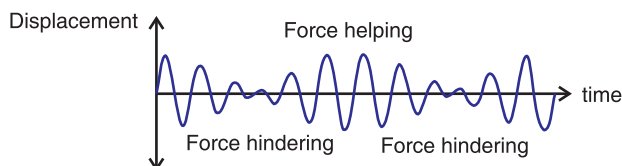

Fig.3-11; The applied force has a frequency closer to the natural frequency

In figure 3.7, the applied force has a frequency closer to the natural frequency. The amplitude of the oscillation has increased and there is time when the force helps and then hinders the oscillations.

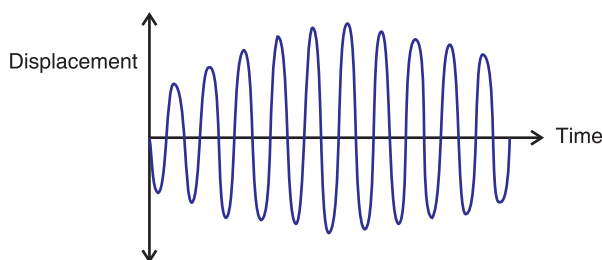

Fig.3-12; Variation of forced frequency on graph at amplitude close to natural frequency of vibration.

The largest amplitude is produced when the frequency of the applied force is the same as the natural frequency of the oscillation. When the energy input from the applied force is equal to the energy loss from the damping, the amplitude stops increasing.

3.8 RESONANCE

When the frequency of excitatory is the same as that of resonator, then the process is called **resonance**. The phenomenon of resonance is quickly increasing of amplitude when the frequency of exciting force approaches the frequency f_o of free oscillations ($f_e \approx f_o$) and $\omega_e \approx \omega_o$ from the equation

of amplitude resonance is $A = \frac{F_0}{\sqrt{(\omega_0^2 - \omega_e^2)^2 + 4\delta^2 \omega_e^2}} = \frac{F_0}{2\delta\omega_e}$ therefore the amplitude of

$$A_r = \frac{F_0}{2\delta\omega_e} \quad \text{..... Equation 3-22}$$

At resonance, the amplitude is maximum there is small damping, the vibrating frequency f_0 of a system is called **resonant frequency** and the region of the graph near f_0 is called the **resonance peak**.

There is maximum amplitude if $(\omega_0^2 - \omega_e^2)^2 + 4\delta^2 \omega_e^2$ is minimum then

$$\frac{d}{d\omega_e} [(\omega_0^2 - \omega_e^2)^2 + 4\delta^2 \omega_e^2] = 0$$

$$2(-2\omega_e)(\omega_0^2 - \omega_e^2) + 8\delta^2 \omega_e = 0$$

$$-4\omega_e(\omega_0^2 - \omega_e^2) + 8\delta^2 \omega_e = 0$$

$$(\omega_0^2 - \omega_e^2) - 2\delta^2 = 0$$

$$\omega_e = \sqrt{\omega_0^2 - 2\delta^2}$$

The angular speed of resonance $\omega_e = \sqrt{\omega_0^2 - 2\delta^2}$ Equation 3-23

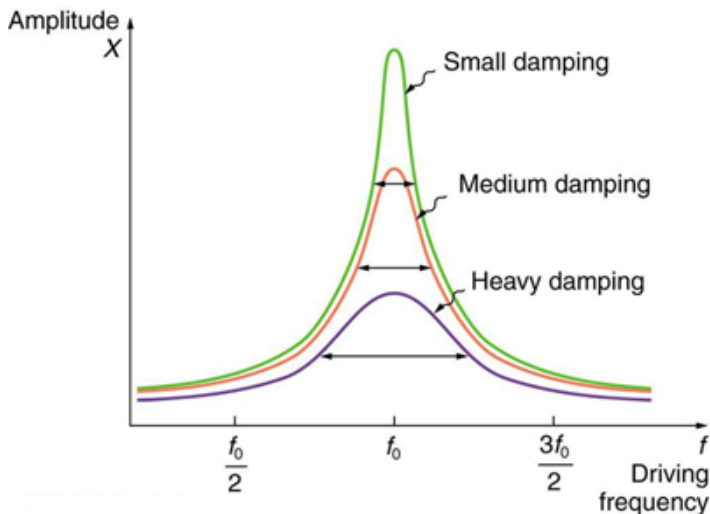

Fig.3. 13 Response curve for a resonance

3.9 APPLICATIONS AND EXAMPLES OF RESONANCE IN EVERYDAY LIFE

The phenomenon of resonance depends upon the whole functional form of the driving force and occurs over an extended interval of time rather than at some particular instant. Below are examples of resonance in different applications;

3.9.1 A washing machine

A washing machine may vibrate quite violently at particular speeds. In each case, resonance occurs when the frequency of a rotating part (motor, wheel, drum etc.) is equal to a natural frequency of vibration of the body of the machine. Resonance can build up vibrations of large amplitude.

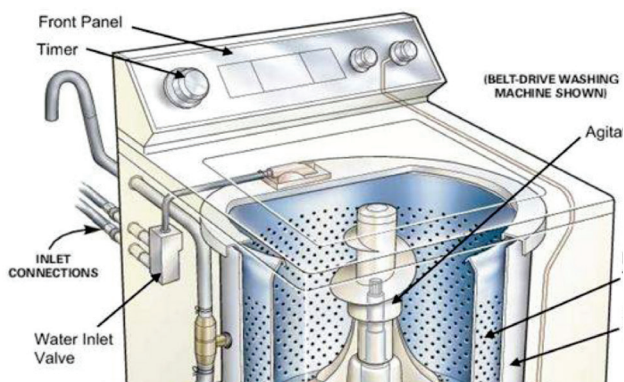

Fig.3-14; A washing machine

3.9.2 Breaking the glass using voice

You must have heard the story of an opera singer who could shatter a glass by singing a note at its natural frequency. The singer sends out a signal of varying frequencies and amplitudes that makes the glass vibrate. At a certain frequency, the amplitude of these vibrations becomes maximum and the glass fails to support it and breaks it. This scenario is shown on Fig.3-10 below.



Fig.3-15; Opera singer breaking the glass

3.9.3 Breaking the bridge

The wind, blowing in gusts, once caused a suspension bridge to sway with increasing amplitude until it reached a point where the structure was overstressed and the bridge collapsed. This is caused by the oscillations of the bridge that keep varying depending on the strength of the wind. At a certain level, the amplitude of oscillation becomes maximum and develops crack on it and suddenly breaks.



Fig.3-16; Vibrations breaking the bridge

3.9.4 Musical instruments

Wind instruments such as flute, clarinet, trumpet etc. depend on the idea of resonance. Longitudinal pressure waves can be set up in the air inside the instrument. The column of air has its own **natural frequencies** at which it can vibrate. When we blow, we use the mouthpiece to start some vibrations. Those which happen to match exactly the natural frequencies of the instrument are picked out and magnified.



Fig.3-17; Howard Johnson's musical trailblazing

3.9.5 Tuning circuit

The another example of useful resonance is the tuning circuit on a radio set. Radio waves of all frequencies strike the aerial and only the one which is required must be picked out. This is done by having a capacitance-inductance combination which resonates to the frequency of the required wave. The capacitance is variable; by altering its value other frequencies can be obtained.

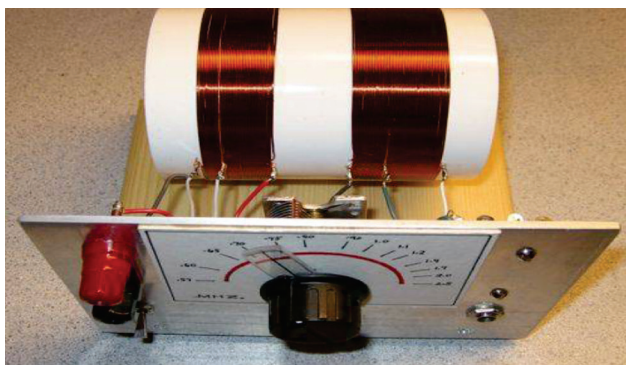

Fig.3-18; Radio receiver tuning circuit

3.9.6 Microwave Ovens

Microwave ovens use resonance. The frequency of microwaves almost equals the natural frequency of vibration of a water molecule. This makes the water molecules in food to resonate. This means they take in energy from the microwaves and so they get hotter. This heat conducts and cooks the food.

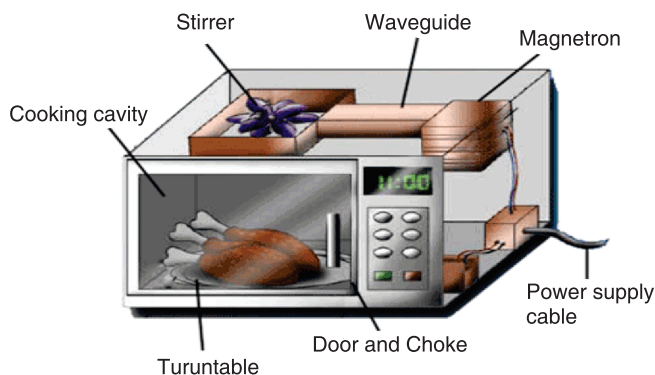

Fig.3-19; Micro wave oven

3.9.7 Magnetic Resonance Imaging (MRI)

The picture showing the insides of the body was produced using magnetic resonance imaging (MRI). Our bodies contain a lot of hydrogen, mostly in

water. The proton in a hydrogen spins. A spinning charged particle has a magnetic field, so the protons act like small magnets. These are normally aligned in random directions. Placing a patient in a strong magnetic field keeps these mini magnets align almost in line. Their field axis just rotates like a spinning top. This is called processing.

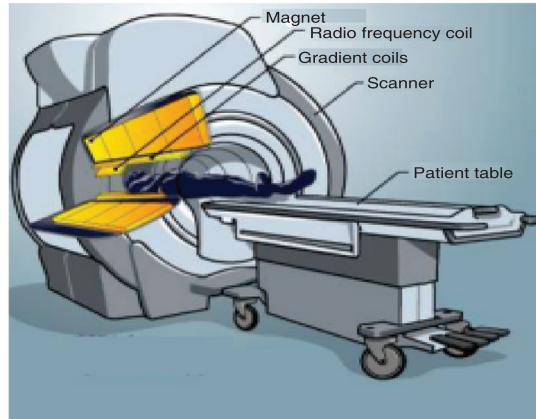

Fig.3-20; Magnetic Resonance Imaging

3.10 EFFECT OF RESONANCE ON A SYSTEM

- ◇ Vibrations at resonance can cause bursting of the blood vessel.
- ◇ In a car crash a passenger may be injured because their chest is thrown against the seat belt.
- ◇ The vibration of kinetic energy from the wave resonates through the rock face and causes cracks.
- ◇ It is also used in a guitar and other musical instruments to give loud notes.
- ◇ Microphones and diaphragm in the telephone resonate due to radio waves hitting them.
- ◇ Hearing occurs when eardrum resonates to sound waves hitting it.
- ◇ Soldiers do not march in time across bridges to avoid resonance and large amplitude vibrations. Failure to do so caused the loss of over two hundred French infantry men in 1850.
- ◇ If the keys on a piano are pushed down gently enough it is possible to avoid playing any notes. With the keys held down, if any loud noise happens in the room (e.g. Somebody shouting), then some of the notes held down will start to sound.
- ◇ An opera singer claims to be able to break a wine glass by loudly singing a note of a particular frequency.

END OF UNIT ASSESSMENT

- Solve the following initial value problem and determine the natural frequency, amplitude and phase angle of each solution.

$$\frac{d^2y}{dt^2} + 25y = 0, y(0) = -2, \frac{dy}{dt} = 10\sqrt{3}$$

- Solve the following initial value problem. For each problem, determine whether the system is under, over, or critically damped.

$$3\frac{d^2y}{dt^2} + 24\frac{dy}{dt} + 48y = 0, y(0) = -5, \frac{dy}{dt} = 6$$

- Consider a mass-spring system described by the equation $2\frac{d^2y}{dt^2} + 3\frac{dy}{dt} + ky = 0$. Give the value(s) of k for which the system is under, over, and critically damped.

- Damping is negligible for a 0.150 kg object hanging from a light 6.30 N/m spring. A sinusoidal force with an amplitude of 1.70 N drives the system. At what frequency will the force make the object vibrate with an amplitude of 0.440 m?
- A 10.6 kg object oscillates at the end of a vertical spring that has a spring constant of . The effect of air resistance is represented by the damping coefficient . Calculate the frequency of the damped oscillation.
1. A body of mass 0.5 kg suspended on a spring constant 50 N/m, describes the damped oscillation with coefficient of resistance . At the upper end it is applied the exciting force . Calculate the damping constant and the amplitude of resonance of this system.
7. A body of mass 0.5 kg suspended on a spring constant 50 N/m, describes the damped oscillation with coefficient of resistance . At the upper end it is applied the exciting force . Calculate the damping constant and the amplitude of resonance of this system.

UNIT SUMMARY

Damping is a dissipating force that is always in the opposite direction to the direction of motion of the oscillating particle and is represented by equation;

$$m \frac{d^2x}{dt^2} + b \frac{dx}{dt} + kx = 0$$

The **natural frequency** of an object is the frequency of oscillation when released. e.g. a pendulum.

A **forced oscillation** is where an object is subjected to a force that causes it to oscillate at a different frequency than natural frequency. It is represented by differential equation;

$$m \frac{d^2x}{dt^2} + b \frac{dx}{dt} + kx = F_0 \cos \omega t$$

Resonance occurs when an object capable of oscillating, has a force applied to it with a frequency equal to its natural frequency of oscillation. Resonance occurs when angular frequency of oscillation is related to natural angular frequency according to equation;

$$\omega = \sqrt{\omega_0^2 - \delta^2}$$

In real life, resonance is applied in;

- A washing machine
- Breaking the glass using the voice
- Breaking the bridge
- Musical instruments
- Tuning circuit
- Microwave ovens
- Magnetic Resonance Imaging (MRI)

**UNIT
4**

PROPAGATION OF MECHANICAL WAVES

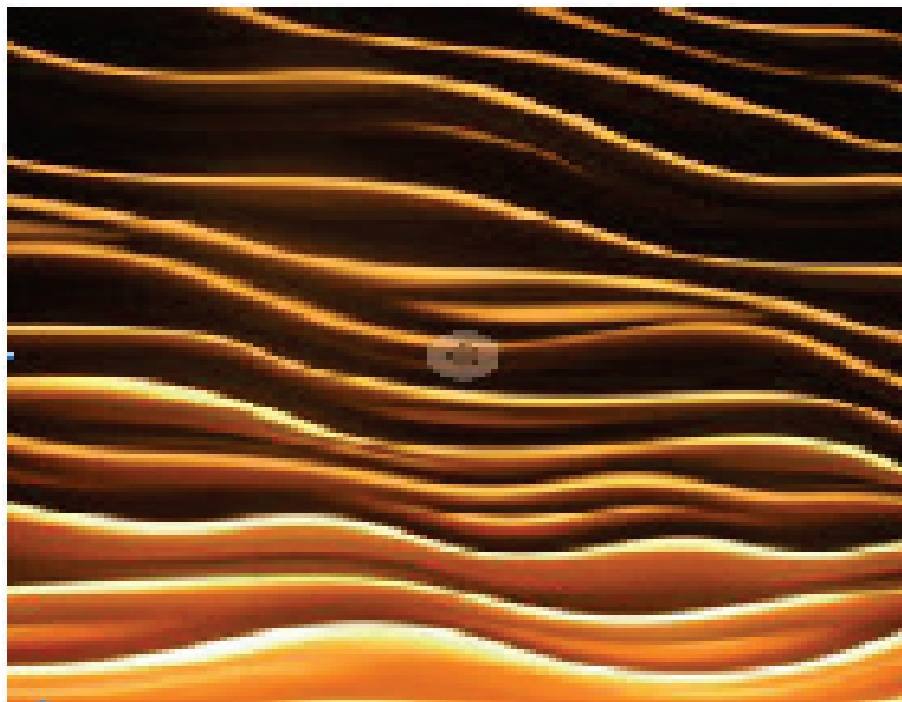

Key unit competence: By the end of the unit I should be able to evaluate the propagation of mechanical waves.

Unit Objectives:

By the end of this unit I will be able to;

- ◇ Explain the terms, concept and characteristics of waves properly.
- ◇ Explain the properties of waves.
- ◇ Explain the behavior of waves in vibrating strings and applications of waves properly.

Introductory Activity

- a. Arrange yourselves the form of a circle with your right shoulders pointing towards the centre.
- b. Ask your friend to raise arms and then lower them. Then the next friend raises arms and lowers them, and so on around the circle. It should be like the “wave”.
- c. Describe the type of the disturbance formed.
- d. Is the disturbance travelling up and down or horizontally around the circle?
- e. Let one of your friend gently push the back of the next student and then the pushed member should gently push the next member and so on, which will make a wave travel around the ring.
- f. From what you have done, can you describe what a disturbance is? Is the disturbance travelling up and down or around the ring?

4.0 INTRODUCTION

When we think of the word “wave”, we usually visualize someone moving his hand back and forth to say ‘hello’ or maybe we think of a tall curling wall of water moving in from the ocean to crash on the beach.

In physics, a wave is a disturbance that occurs in a material medium and in such process, energy is transferred from one place to another. When studying waves, it’s important to remember that they transfer energy, not matter.

There are lots of waves all around us in everyday life. Sound is a type of wave that moves through matter and then vibrates our eardrums and we hear. Light is a special kind of wave that is made up of photons that helps us to see. You can drop a rock into a pond and see wave formation in the water. We even use waves (microwaves) to cook our food really fast. Application of this concept is extensively used in telecommunication and music.

4.1 THE CONCEPT OF WAVES

Waves can be defined as a disturbance in a medium that transfers energy from one place to another, although the medium itself does not travel.

The term wave is often intuitively understood as referring to a transport

of spatial disturbances that are generally not accompanied by a motion of the medium occupying this space as a whole. In a wave, the energy of a vibration is moving away from the source in the form of a disturbance within the surrounding medium. Other properties, however, although usually described in terms of origin, may be generalized to all waves. For such reasons, wave theory represents a particular branch of physics that is concerned with the properties of wave processes independently of their physical origin.

4.2 TERMS USED AND CHARACTERISTICS OF WAVES

All waves are characterized by the following terms;

The **Time period (T)** of the wave is the time it takes for one wavelength of the wave to pass a point in space or the time for one cycle to occur. It is also defined as the time taken between two successive wave crests or trough. It is measured in seconds (s).

The **frequency (f)** is the number of wavelengths that pass a point in space per second. In another words, it can be defined as the number of complete oscillations or vibrations per second. Its SI unit is hertz (Hz). Mathematically;

$$f = \frac{1}{T} \quad \text{..... Equation 4-1}$$

The **wavelength (λ)** is the horizontal distance in space between two nearest points that are oscillating in phase (in step) or the spatial distance over which the wave makes one complete oscillation. Its SI unit is metre (m).

The **wave speed (v)** is the speed at which the wave advances. Its SI unit is m/s.

$$\text{Speed} = \frac{\text{distance travelled}}{\text{time period}} = \frac{\lambda}{T} \quad \text{..... Equation 4-2}$$

$$v = \lambda f$$

That is, wave speed = wavelength \times frequency.

This is the relationship between wavelength, frequency and velocity.

Amplitude is defined as the maximum distance measured from equilibrium position (mean position). The amplitude is always taken as positive and is measured in metres.

Phase difference (phase angle) is the angular difference between two points on the wave or between two waves. Consider, two points O and P on the wave as shown in Fig. 4-12.

Phase difference is a whole number and is calculated using simple proportions;

$$\phi = \frac{2\pi x}{\lambda} \quad \text{..... Equation 4-3}$$

The **wave number**, also called the propagation number k , is the spatial frequency of a wave, either in cycles per unit distance or radians per unit distance. It can be envisaged as the number of waves that exist over a specified distance (analogous to frequency being the number of cycles or radians per unit time). Its unit is per metre (m^{-1}). Mathematically;

$$k = \frac{\Phi}{x} = \frac{2\pi}{\lambda} \quad \text{..... Equation 4-4}$$

The **Intensity (I)** of a wave or the power radiated by a source are proportional to the square of the amplitude (x).

$$I \propto x^2$$

Wavefront is a line or surface in the path of the wave motion on which the disturbance at every point have the same phase. This can also be defined as the surface which touches all the wavelets from the secondary sources of waves. Consider the Huygens construction principle for the new wavefront.

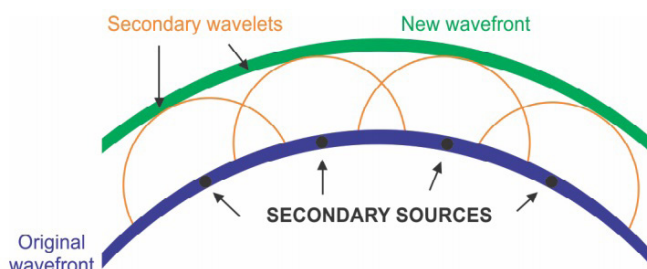

Fig. 4.1: Formation of the wavefront

Crest is the highest point above the equilibrium position while **trough** is the lowest point below then equilibrium position.

The angular frequency ω represents the frequency in radians per second. It is related to the frequency by

$$\omega = 2\pi f = \frac{2\pi}{T}$$

A **node** is a point half way between the crest and the trough. The line that connects the nodes is the **nodal line**. The nodal line shows the original position of the matter carrying the wave.

Application Activity 4.1

1. Requirements: a manila paper with the drawing of the wave shown below



- How do you call the distance represented by arrow z?
- What letter is labelling the wave's trough?
- What letter is labelling a wave's crest?
- The number of waves that pass the poster per second is called the of the waves.
- If the knot (w) travels 2 meters in 1 second, we say that it has
..... of 2 m/s.
- If the wavelengths were shortened, would the frequency be higher or lower?
- The greatest distance the knot (w) travels from its resting position is called..... of the wave.
- What kind of wave are these in the rope?

2. Use the following descriptions in waves and fill in the crossword puzzle below:

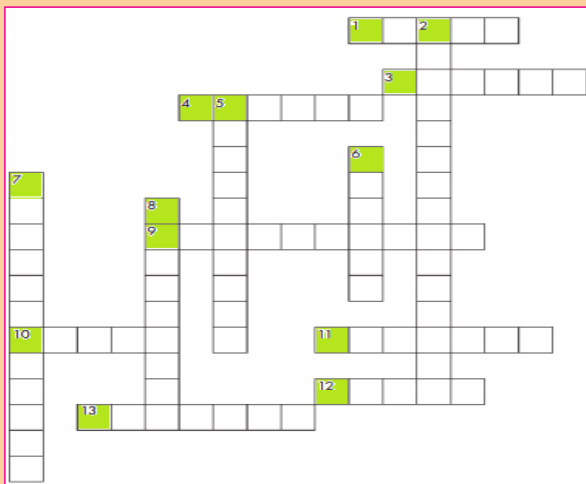

Across

1. How fast something is moving or how much distance is covered in a certain amount of time.
3. The time it takes for a wave to repeat itself
4. The lowest point of a wave beneath the line of origin
9. Waves that require a medium
10. The highest point of a wave above the line of origin
11. Particles of light
12. A push or a pull
13. The tendency of an object at rest to remain at rest or in motion until acted upon

Down

1. Waves that do not require a medium
2. The bouncing back of a wave when it meets the surface or boundary
3. The matter through which a wave travels
4. Distance in a given direction
5. The vertical distance between the line of origin and the crest of a wave

4.3 TYPES OF WAVES

Waves are of three main types: Mechanical wave, electromagnetic wave and matter wave.

These waves are classified based on conditions necessary for the wave to propagate

4.3.1 Mechanical waves

These waves are produced by the disturbance in a material medium and they are transferred by particles of the medium.

The matter through which mechanical waves travel is called the medium. All mechanical waves require (1) some source of disturbance, (2) a medium that can be disturbed, and (3) some physical mechanism through which elements of the medium can influence each other.

Mechanical Waves are divided into two types according to the direction of the displacements in relation to the direction of the motion of the wave itself (wave form):

a) Longitudinal waves

When a wave propagates through some medium and the local displacements of the medium that constitute the disturbance are in the direction of travel of the disturbance, then the wave is longitudinal.

An example of a longitudinal wave is the pulse that can be sent along a stretched slinky by shaking one end of the slinky along its length. The pulse moves along the line of the slinky and ultimately makes the other end move. Notice that in this case, the individual coils of the slinky vibrate back and forth about some equilibrium position, but there is no net movement of the slinky itself.

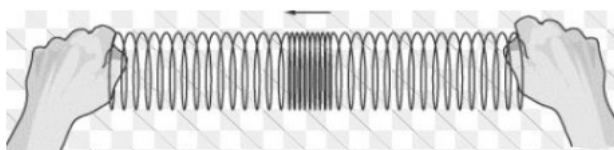

Fig. 4.2: Longitudinal wave

b) Transverse waves

These are waves in which the direction of disturbance is perpendicular to the direction of travel of the wave. The particles do not move along with the wave; they simply oscillate up and down about their individual equilibrium positions as the wave passes by.

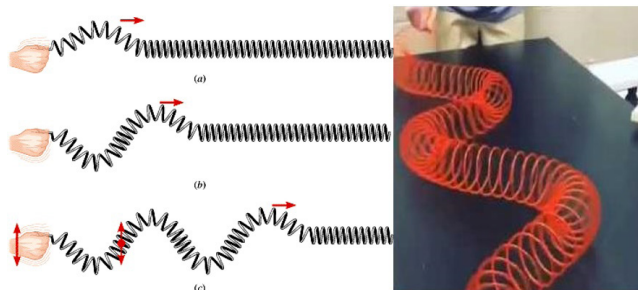

Fig. 4.3: Transverse waves

4.3.1.4 Examples of mechanical waves

Mechanical waves, being progressive and stationary, are seen in different forms as described in this section.

Sound waves

Sound waves are longitudinal waves. Sound waves travel fastest in solids, slower in liquids and slowest in gases. This means the air particles (or particles of the medium) move back and forth on paths that are parallel to the direction of wave propagation and thus take the form of compressions and rarefactions of the molecules in the air itself.



Fig. 4.4: Sound waves

Water waves

Water waves are a combination of both transverse and longitudinal waves. These waves are periodic disturbances that move away from the source and carry energy as they go.



Fig. 4.5: Water waves

Ocean waves

These waves are longitudinal waves that are observed moving through the bulk of liquids, such as our oceans. Ocean waves are powerful forces that erode and shape of the world's coastlines. Most of them are created by the wind. Winds that blow over the top of the ocean, create friction between the air and water molecules, resulting in a frictional drag as waves on the surface of the ocean.



Fig. 4.6: Ocean waves

Earthquake waves

Earthquakes occur when elastic energy is accumulated slowly within the Earth's crust (as a result of plate motions) and then released suddenly along fractures in the crust called faults. Earthquake waves are also called seismic waves and actually travel as both transverse and longitudinal waves.

The P waves (Primary waves or compressional waves) in an earthquake are examples of longitudinal waves. The P waves travel with the fastest velocity and are the first to arrive.

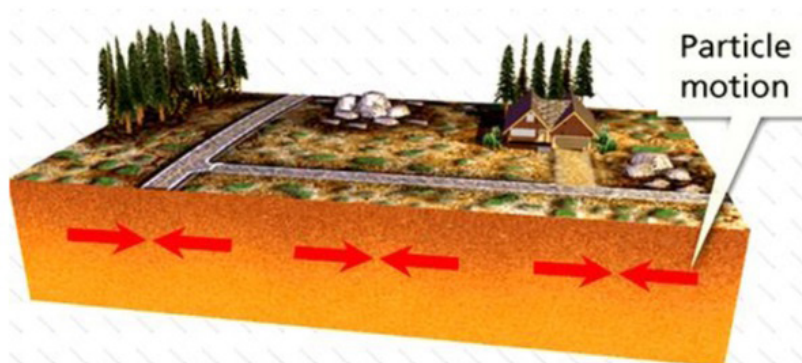

Fig. 4.7: P Seismic waves

The S waves (Secondary waves or shear waves) in an earthquake are examples of transverse waves. S waves propagate with a velocity slower than P waves, arriving several seconds later.

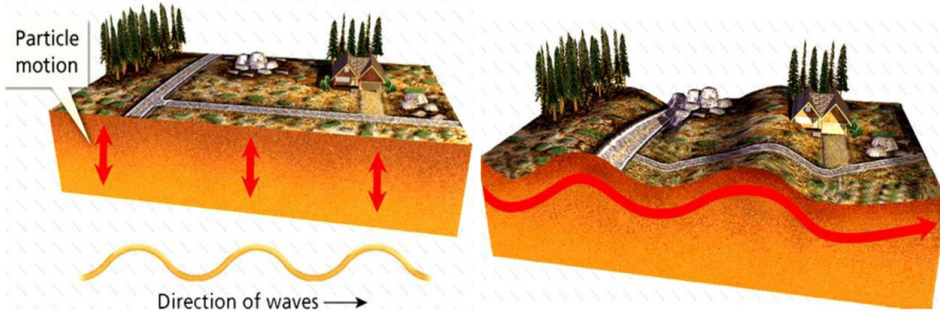

Fig. 4.8: S seismic waves

Body Waves

Body waves are of two types: compressional or primary (P) waves which are longitudinal in nature and shear or secondary (S) waves which are transverse in nature. P- and S- waves are called 'body waves' because they can travel through the interior of a body, such as the Earth's inner layers, from the focus of an earthquake to distant points on the surface. The Earth's molten core are only travelled by compressional waves.

Surface Waves

When waves occur at or near the boundary between two media, a transverse wave and a longitudinal wave can combine to form a surface wave. Examples of surface waves are a type of seismic wave formed as a result of an earthquake and water waves.

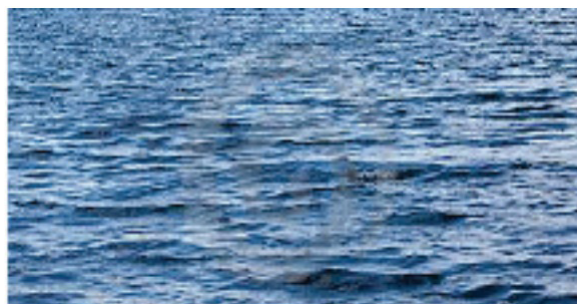

Fig.4.9: Surface water waves.

4.3.2 Electromagnetic waves

These waves consist of disturbances in the form of varying electric and magnetic fields. No material medium is necessary for their movement and they travel more easily in vacuum than in matter.

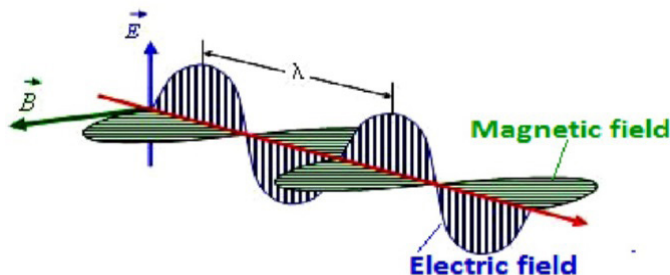

Fig. 4-10: Electromagnetic waves

Examples of electromagnetic waves are: Radio waves, Microwaves, Infrared radiation, Visible light, Ultraviolet light, X-rays and Gamma rays. These waves vary according to their wavelengths.

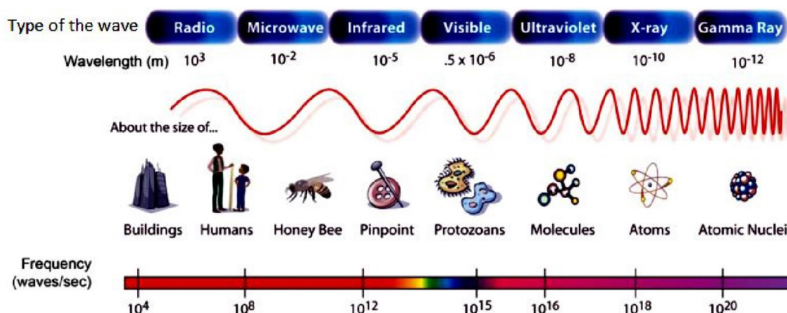

Fig. 4-11: Examples of electromagnetic waves

4.3.3 Matter Waves

If we perform the double slit diffraction experiment using a beam of electrons instead of light, we still get a diffraction pattern. The interpretation of this is that **matter travels as a wave**. Thus “matter acts as both a particle and as a wave.” If we can sometimes consider an electron to be a wave, what is its wavelength? Louis de Broglie postulated that all particles with momentum have a wavelength

$$\lambda = \frac{h}{p} = \frac{h}{mv} \quad \text{..... Equation 4-5}$$

Where

- $h = 6.63 \times 10^{-34} \text{ J} \cdot \text{s}$ is Planck’s constant (energy of a photon divided by its frequency),
- p is the magnitude of the momentum of the particle.

The matter waves describe the wavelike characteristics of atomic-level particles.

For mechanical waves, the speed of the wave is a property of the medium, speed does not depend on the size or shape of the wave.

Example 4.1

1. Find de Broglie wavelength for

a) a particle of mass $m = 10^{-6}$ g moving with a speed of $v = 10^{-6}$ m/s .

b) a baseball of mass 0.17 kg moving at 100 km/h

answer

$$\text{a) } \lambda = \frac{h}{mv} = \frac{6.63 \times 10^{-34}}{10^{-9} \times 10^{-6}} = 6.63 \times 10^{-19} \text{ m}$$

$$\text{b) } \lambda = \frac{h}{mv} = \frac{6.63 \times 10^{-34} \times 3600}{0.17 \times 100 \times 10^3} = 1.4 \times 10^{-34} \text{ m}$$

4.4 PROGRESSIVE WAVES

A progressive wave is also called a travelling wave which consists of a disturbance moving from one point to another. As a result, energy is transferred between points. Progressive mechanical waves can be categorised according to the direction of the effect of the disturbance relative to the direction of travel.

Equation of a progressive wave

An equation can be performed to represent displacement y of a vibrating particle in a medium in which a wave passes. Suppose a wave moves from left to right and that a particle at the origin moves with displacement given by equation.

$$y_A = A \sin \omega t \quad \text{..... Equation 4-6}$$

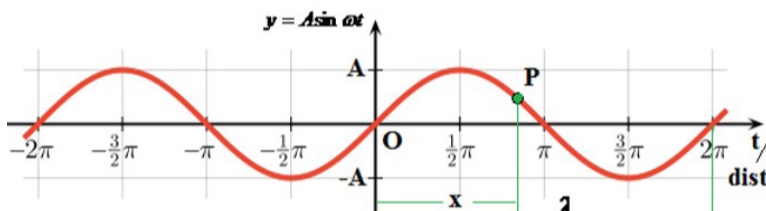

Fig. 4-12: Curve of Transverse wave

A particle at P will be out of phase from the particle at O , so, its displacement is given by;

$$y_p = A \sin(\omega t - \Phi)$$

But the phase angle

$$\Phi = \frac{2\pi x}{\lambda}$$

$$y_p = A \sin 2\pi\left(\omega t - \frac{2\pi x}{\lambda}\right) \dots\dots\dots \text{Equation 4-7}$$

Various forms of progressive wave function are listed below;

$$y_p = A \sin 2\pi\left(ft - \frac{x}{\lambda}\right) \dots\dots\dots \text{Equation 4-8}$$

$$y_p = A \sin 2\pi\left(\frac{t}{T} - \frac{x}{\lambda}\right) \dots\dots\dots \text{Equation 4-9}$$

$$y_p = A \sin \frac{2\pi}{\lambda}(vt - x) \dots\dots\dots \text{Equation 4-10}$$

$$y_p = A \sin \omega\left(t - \frac{x}{v}\right) \dots\dots\dots \text{Equation 4-11}$$

where y = displacement

A = amplitude

ω = angular frequency

f = frequency

k = propagation constant

T = time period

λ = wave length

v = wave velocity

t = instantaneous time

x = position of particle from origin

Equations 4.7 to 4.11 represent plane progressive waves. The negative sign indicates that the wave is moving from left to right and all points on the right of O will lag behind O .

A wave travelling in opposite direction; from right to left arrives at P before O . So, vibrations at P will read that at O and then displacement is given by;

$$y_p = A \sin 2\pi\left(\omega t + \frac{2\pi x}{\lambda}\right) \dots\dots\dots \text{Equation 4-12}$$

$$y_p = A \sin 2\pi\left(ft + \frac{x}{\lambda}\right) \dots\dots\dots \text{Equation 4-13}$$

$$y_p = A \sin 2\pi\left(\frac{t}{T} + \frac{x}{\lambda}\right) \dots\dots\dots \text{Equation 4-14}$$

$$y_p = A \sin \omega\left(t + \frac{2\pi x}{\lambda}\right) \dots\dots\dots \text{Equation 4-15}$$

EXAMPLE 1

A travelling wave is described by the equation $y(x, t) = 0.003 \cos (20x + 200t)$ where y and x are measured in metres and t in seconds. What is the direction in which the wave is travelling? Calculate the following physical quantities:

- angular wave number
- wavelength
- angular frequency
- frequency
- time period
- wave speed
- amplitude
- particle velocity when $x = 0.3$ m and $t = 0.02$ s
- particle acceleration when $x = 0.3$ m and $t = 0.02$ s

Solution:

The equation $y(x, t) = 0.003 \cos (20x + 200t)$ has the form $y = A \sin (\omega t + \Phi)$. So, it is travelling towards- x direction.

- Angular wave number or propagation constant, $k = \frac{\Phi}{x} = \frac{20x}{x} = 20 \text{ m}^{-1}$
- Wavelength: $k = \frac{2\pi}{\lambda} \Rightarrow \lambda = \frac{2\pi}{k} = \frac{2\pi}{20} = 0.31 \text{ m}$.
- Angular frequency, $\omega = 200 \text{ rad/s}$
- Frequency, $f = \frac{\omega}{2\pi} = \frac{200}{2\pi} = 32 \text{ Hz}$
- Time Period, $T = \frac{1}{f} = \frac{1}{32} = 0.031 \text{ s}$
- Wave speed, $v = \lambda f = 0.31 \times 32 = 10 \text{ m/s}$ (approx.)
- Amplitude, $A = 0.003 \text{ m}$
- Given; $x = 0.3 \text{ m}$, $t = 0.02 \text{ s}$

$$\therefore v = \frac{dy}{dt} = -0.003 \times 200 \sin(20x + 200t) = -0.6 \sin 10 = +0.33 \text{ m/s}$$

(i) Given; $x = 0.3 \text{ m}$, $t = 0.02 \text{ s}$

$$\therefore a = \frac{dv}{dt} = -0.6 \times 200 \cos(20x + 200t) = -120 \cos 10 = +101 \text{ m/s}^2$$

4.5 PRINCIPLE OF SUPERPOSITION

The displacement at any time due to any number of waves meeting simultaneously at a point in a medium is the vector sum of the individual displacements of each one of the waves at that point at the same time.

This means that when two waves travel in a medium, their combined effect at any point can be determined using this principle. Consider two waves of displacements y_1 and y_2 passing through the same medium. The resultant displacement after superposition is:

$$y = y_1 + y_2 \quad \text{..... Equation 4-17}$$

When two pulses of equal or different amplitudes on a string approach each other, then on meeting, they superimpose to produce a resultant pulse of amplitude greater than any of the two. After crossing, the two pulses travel independently.

4.5.1 Stationary waves

A stationary wave (or a standing wave) is a wave which results when two waves travelling in opposite directions and having the same speed, frequency and approximately equal amplitudes are superposed. A standing wave is shown in Fig. 4.6 below.

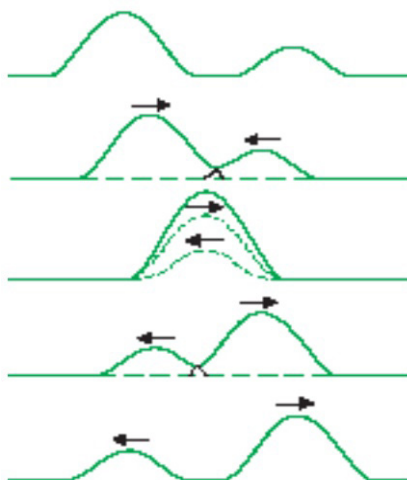

Fig. 4-14: Superposition of waves

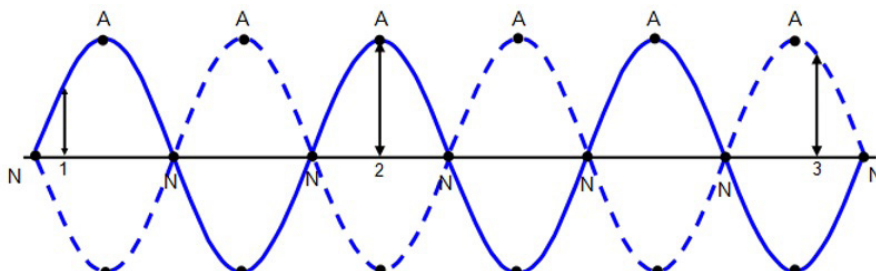

Fig. 4-15: Nodes and antinodes of a standing wave.

Here, A denotes the antinodes and N denotes the nodes.

Consider the displacement $y_1 = a \sin(\omega t - \Phi)$ of a progressive sinusoidal wave at time t and at a distance x from the origin and moving to right.

Consider also the displacement y_2 of an identical wave travelling in opposite direction given by;

$$y_2 = a \sin(\omega t + \Phi).$$

If these waves are superposed, the resultant displacement y is given by;

$$y = y_1 + y_2 \Rightarrow y = a \sin(\omega t - \Phi) + a \sin(\omega t + \Phi)$$

\Rightarrow

$$y = 2a \cos \Phi \sin \omega t$$

$$= 2a \cos kx \sin \omega t \quad \dots\dots\dots \text{Equation 4-18}$$

$$[\Phi = kx, \text{Eq. (4.4)}]$$

The only variable part of equation 4.18 is $\sin \omega t$. This means that the amplitude of the resultant displacement is given by equation

$$A = 2a \cos kx \quad \dots\dots\dots \text{Equation 4-19}$$

4.5.2 Mathematical treatment of superposition

Position of nodes

A node is defined as the point of zero amplitude. This means

$$A = 2a \cos kx = 0$$

\Rightarrow

$$\cos kx = 0 \quad \dots\dots\dots \text{Equation 4-20}$$

\Rightarrow

$$kx = \cos^{-1}(0)$$

\therefore

$$kx = \frac{\pi}{2}, \frac{3\pi}{2}, \frac{5\pi}{2}, \frac{7\pi}{2}, \dots$$

But $k = \frac{2\pi}{\lambda}$ [Eq. (4.4)]

\therefore

$$x = \frac{\lambda}{4}, \frac{3\lambda}{4}, \frac{5\lambda}{4}, \frac{7\lambda}{4}, \dots$$

That is,

$$x = \frac{m\lambda}{4} \quad \dots\dots\dots \text{Equation 4-21}$$

where $m = 1, 3, 5, 7, 9, \dots$

Equation (4.21) means that nodes are obtained when the horizontal displacement of waves are odd quarter values of wavelength.

Position of antinodes

Antinodes are points of maximum displacements. So, antinodes are obtained when the value of Equation 4.19 is maximum. This occurs when;

$$\cos kx = 1 \quad \dots\dots\dots \text{Equation 4-22}$$

$$\Rightarrow kx = \cos^{-1}(1)$$

$$\Rightarrow kx = 0, \pi, 2\pi, 3\pi, 4\pi, 6\pi, \dots$$

$$x = 0, \frac{\lambda}{2}, \frac{2\lambda}{2}, \frac{3\lambda}{2}, \frac{4\lambda}{2}, \frac{5\lambda}{2}, \frac{6\lambda}{2}, \dots$$

That is
$$x = \frac{n\lambda}{2} \dots\dots\dots \text{Equation 4-23}$$

where $n = 0, 1, 2, 3, 4, 5, 6, \dots$

This means that antinodes are obtained when horizontal displacement x is a multiple of $\frac{\lambda}{2}$.

Note: The separation of adjacent nodes and adjacent antinodes are $\frac{\lambda}{2}$.

$$\left(\begin{array}{l} \text{Seperation of} \\ \text{adjacent nodes} \end{array} \right) = \left(\begin{array}{l} \text{Seperation of} \\ \text{adjacent antinodes} \end{array} \right) = \frac{\lambda}{2} \quad \dots\dots\dots \text{Equation 4-24}$$

EXAMPLE 2

Find the path difference between the two waves $y_1 = \sin\left(\omega t - \frac{2\pi x}{\lambda}\right)$ and

$$y_2 = a_2 \cos\left(\omega t - \frac{2\pi x}{\lambda} + \phi\right) = a_2 \sin\left(\omega t - \frac{2\pi x}{\lambda} + \phi + \frac{\pi}{2}\right)$$

Solution:

$$\text{Phase difference} = \Delta\phi = \left(\omega t - \frac{2\pi x}{\lambda} + \phi\right) - \left(\omega t - \frac{2\pi x}{\lambda}\right) = \phi + \frac{\pi}{2}$$

$$\text{Path difference} = \Delta x = \frac{2\pi}{\lambda} \Delta\phi = \frac{2\pi}{\lambda} \left(\phi + \frac{\pi}{2}\right)$$

4.6 PROPERTIES OF WAVES

This section introduces the properties of waves and wave motion to describe the behaviour of waves in detail.

4.6.1 Reflection

This is the property of waves to bounce back from the surface on which they

hit. Huygens principle can also be applied to reflection. Consider a parallel beam of light incident on the reflecting surface such that its direction of travel makes an angle i with the normal to the surface.

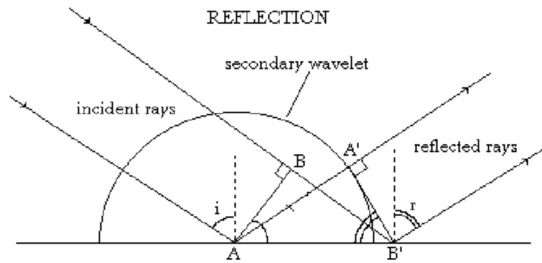

Fig. 4-15: Reflection of waves

Consider that side A of an associated wavefront AB has just reached the surface. In the time that light from side B of the wavefront travels to B' , a secondary wavelet of radius equal to BB' will be generated by A . Because of the reflecting surface, this wavelet is a semicircle above the surface. The new wavefront generated by reflection will be the tangent to this wavelet and will also contain point B' . The reflected wavefront will be $A'B'$.

Triangles ABB' and $B'A'A$ are congruent as

$$\angle A'AB' = \angle BBA' \quad \dots\dots\dots \text{Equation 4-25}$$

$$\angle A'AB' = 90 - r$$

$$\angle BBA' = 90 - i$$

$$90 - r = 90 - i$$

$$\therefore \quad \quad \quad i = r \quad \dots\dots\dots \text{Equation 4-26}$$

We conclude by saying that all laws of reflection are obeyed. So, any wavefront can reflect.

4.6.2 Refraction

Consider a parallel beam of waves (for example light waves) incident on a refracting surface between two media such that its direction of travel makes angle θ_1 with the normal to the refracting surface.

Consider side A of the wavefront AB has reached the surface before B . If the ray from the other side B of the beam consequently travels to C at time t ,

$$BC = C_1 t \quad \dots\dots\dots \text{Equation 4-27}$$

Assuming: $C_1 \rightarrow$ speed of light in medium 1

$C_2 \rightarrow$ speed of light in medium 2

$t \rightarrow$ time taken for the ray to move from B to C

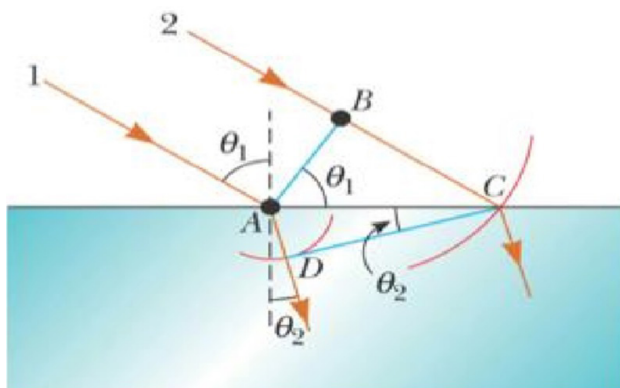

Fig. 4-16: Refraction of waves

At the same time, wavelets from A travel distance AD in medium 2. Here, a refracted wavefront CD is formed by many wavelets in the beam. Fig.4-16 above illustrates this description.

$$AD = C_2 t \quad \text{..... Equation 4-28}$$

Considering triangle ABC and ADC :

$$\sin \theta_1 = \frac{BC}{AC} = \frac{C_1 t}{AC} \quad \text{..... Equation 4-29}$$

$$\sin \theta_2 = \frac{AD}{AC} = \frac{C_2 t}{AC} \quad \text{..... Equation 4-30}$$

Dividing Equation 4.29 by Equation 4.30 gives:

$$\frac{\sin \theta_1}{\sin \theta_2} = \frac{C_1}{C_2} \quad \text{..... Equation 4-31}$$

By Snell's law:

$$\frac{\sin \theta_1}{\sin \theta_2} = \frac{C_1}{C_2} = \text{Constant} \quad \text{..... Equation 4-32}$$

Equation 4-32 confirms Snell's law meaning that waves behave like normal light during reflection.

4.6.3 Interference

In the region where wave trains from coherent sources (sources of the same frequency) cross, superposition occurs giving reinforcements of waves at some points which is called constructive interference and cancellation at others which is called destructive interference. The resulting effect is called interference pattern or the system of fringes.

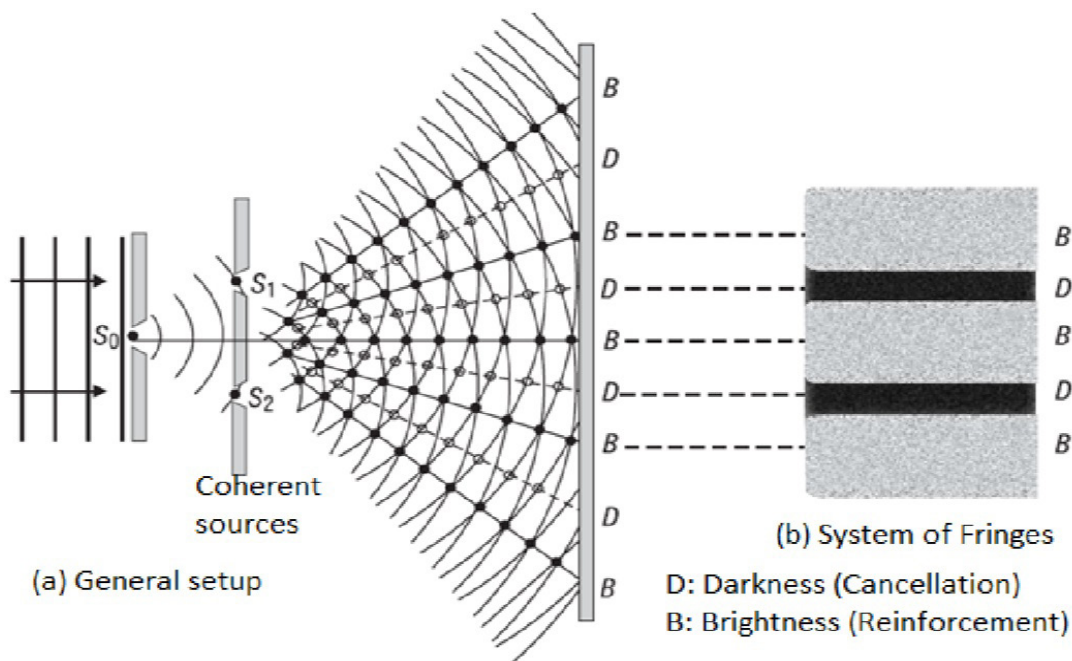

Fig.4.17; Interference of waves

4.6.4 Diffraction

This is a phenomenon in which waves from one source meet an obstacle and spread around it. Diffraction is normally observed when these waves pass through narrow slits. There are two types of diffraction and these are; Fresnel's diffraction and Fraunhofer diffraction.

a) Fresnel's diffraction

This is a type of diffraction in which either the source of waves or screen on which diffraction is observed or both are at finite distances from the obstacle that cause diffraction. Below are different cases to explain this diffraction.

Case 1: the source and the screen placed at finite distances.

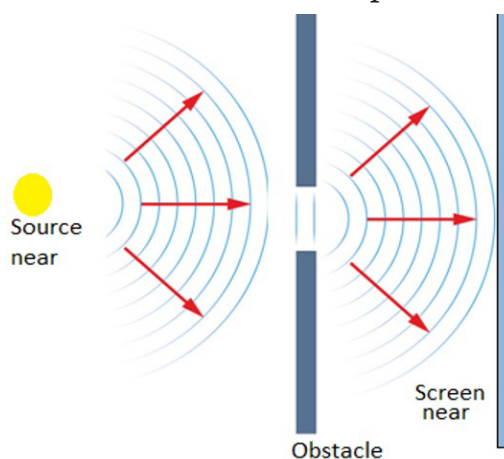

Fig. 4.18: Fresnel's diffraction case 1

Case 2: the source is placed at infinite distance from obstacle and the screen is near.

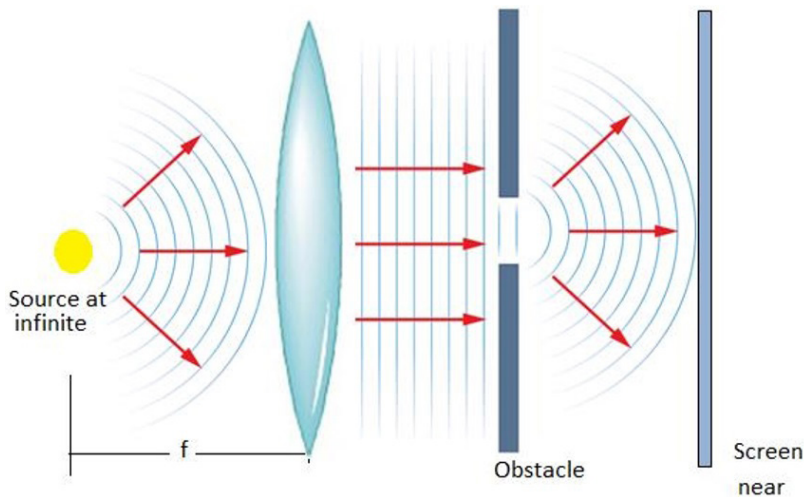

Fig. 4.19: Fresnel's diffraction case 2

Case 3: the screen is placed at infinite distance from obstacle and the source is near.

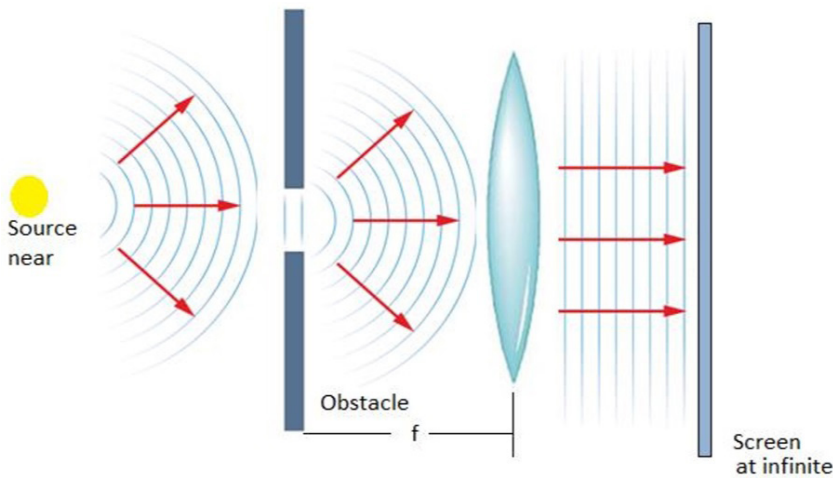

Fig. 4.20: Fresnel's diffraction case 3.

b) Fraunhofer Diffraction

This is a type of diffraction in which the source of waves and the screen on which diffraction is observed are effectively at infinite distances from the obstacle. This phenomenon is practically complicated but theoretically understood. To obtain waves to or from infinite source in laboratory, biconvex lenses are used.

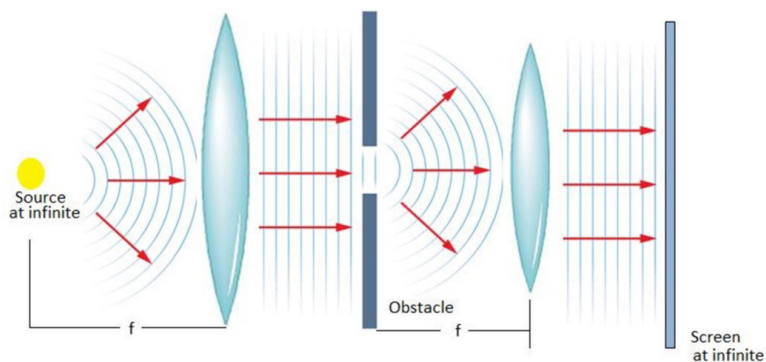

Fig. 4.21: Fraunhofer diffraction

4.7 WAVE ON A VIBRATING STRING

ACTIVITY 4-1: Propagation of Waves

Learning Objectives

- To observe the propagation of vibrations through a solid
- To understand how sound is transmitted through a medium

Required Materials

Spoon, string of length 1 m

Procedure

- Tie the spoon into the middle of the length of string so that it will hang freely when you hold the string ends.
- Hold the string ends to your temples or the bone just under your ears as you strike the spoon with a pen or other object.

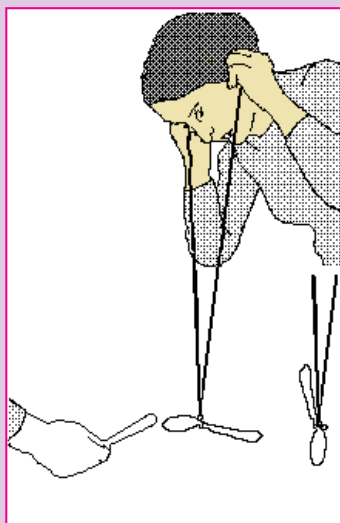

Fig. 4.22: Second overtone

Discussion Questions

1. What causes the sound to be loud when the string is held to your head?
2. Why does the bone in front of your ear transmit vibrations more easily than other bones?
3. What is the purpose of the string in this activity?

Standing wave also known as a **stationary wave**, is wave pattern that results when two waves of the same frequency; wavelength and amplitude travel in opposite directions along string and interfere.

The point at which the two waves cancel are called **node**. There no motion in the string at the nodes, but midway between two adjacent nodes, the string vibrates with the largest amplitude. These points are called **antinodes**. At points between successive nodes the vibrations are in **phase**.

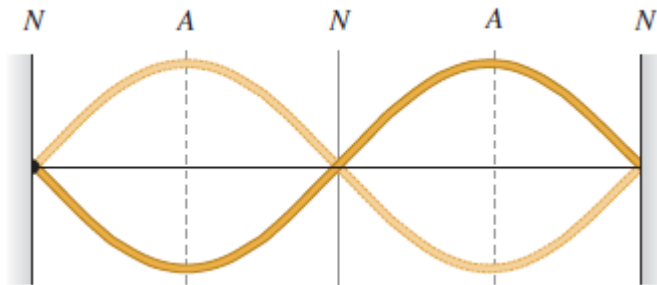

Fig.4. 23 Standing wave with 3 nodes Standing-wave produced at various times by two waves of equal amplitude traveling in opposite directions. For the resultant wave y , the nodes are points of zero displacement, and the antinodes are points of maximum displacement.

A single loop corresponds to either a crest or trough alone, while two loops correspond to a crest and trough together, or one wave length.

Stationary waves are present in the vibrating strings of musical instruments. A violin string, for instance, when bowed or plucked, vibrates as a whole, with nodes at the ends, and also vibrates in halves, with a node at the center, in thirds, with two equally spaced nodes, and in various other fractions, all simultaneously. The vibration as a whole produces the **fundamental tone**, and the other vibrations produce the **various harmonics**.

Standing waves can occur at more than one frequency. The lowest frequency of oscillation that produces a standing wave gives rise to the pattern shown in Fig. 4.24b. The standing waves shown in Figs. 4.24c and 4.24d are produced at precisely twice and three times the lowest frequency,

respectively, assuming the tension in the cord is the same. The cord can also oscillate with four loops (four antinodes) at four times the lowest frequency, and so on.

The frequencies at which standing waves are produced are the **natural frequencies** or **resonant frequencies** of the cord, and the different standing wave patterns shown in Fig. 4.24 are different “resonant modes of vibration.” A standing wave on a cord is the result of the interference of two waves traveling in opposite directions. A standing wave can also be considered a vibrating object at resonance. Standing waves represent the same phenomenon as the resonance of an oscillating spring or pendulum. However, a spring or pendulum has only one resonant frequency, whereas the cord has an infinite number of resonant frequencies, each of which is a whole-number multiple of the lowest resonant frequency.

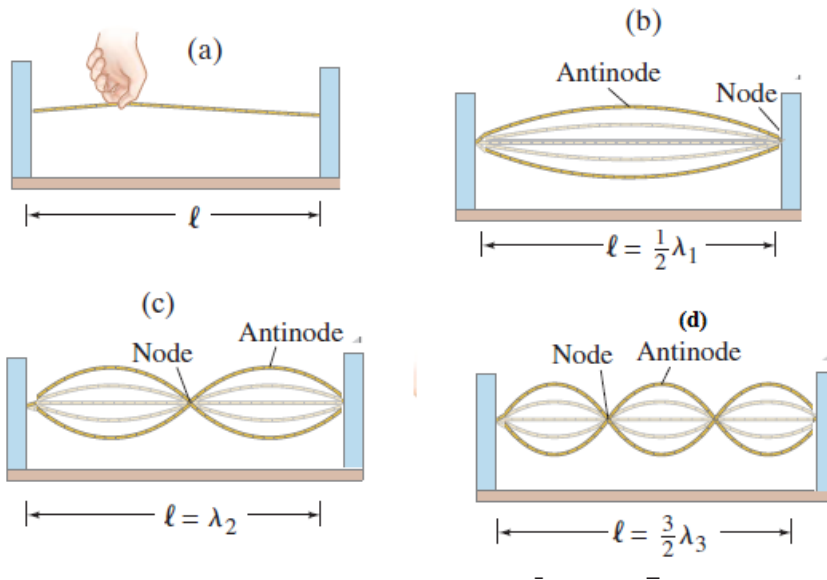

Fig.4. 24(a) A string is plucked; (b) Fundamental or first harmonic

$f_0 = \frac{v}{\lambda}$; **(c) First overtone or second harmonic** $f_1 = 2f_0$; **(d) Second overtone or third harmonic** $f_2 = 3f_0$

To determine the **resonant frequencies**, we first note that the wavelengths of the standing waves bear a simple relationship to the length of

the string and use Eq4.06 $\lambda = \frac{v}{f}$.

The lowest frequency, called the **fundamental frequency**, corresponds to

one antinode (or loop). And as can be seen in Fig. 4.24b, the whole length corresponds to one-half wavelength.

$$\text{Thus } l = \frac{\lambda_1}{2} \Leftrightarrow \lambda_1 = 2l$$

$$\text{Fundamental frequency or 1}^{\text{st}} \text{ harmonic: } f_o = \frac{v}{\lambda_1} = \frac{v}{2l},$$

where λ_1 stands for the wavelength of the fundamental frequency.

The other natural frequencies are called **overtones**; for a vibrating string they are whole-number (integral) multiples of the fundamental, and then are also called **harmonics**, with the fundamental being referred to as the first harmonic. The next mode of vibration after the fundamental has two loops and is called the **second harmonic** (or first overtone), Fig. 4.24c. The length of the string at the second harmonic corresponds to one complete wavelength: $l = \lambda_2$

$$\text{1}^{\text{st}} \text{ overtone or 2}^{\text{nd}} \text{ harmonic } f_1 = \frac{v}{\lambda_2} = \frac{v}{l} = 2f_o$$

$$\text{2}^{\text{nd}} \text{ overtone or 3}^{\text{rd}} \text{ harmonic } f_2 = \frac{v}{\lambda_2} = \frac{3v}{2l} = 3f_o$$

For the 3rd and 4th harmonics $l = \frac{3\lambda_3}{2} \Leftrightarrow \lambda_3 = \frac{2l}{3}$, and $l = \frac{4\lambda_4}{2} \Leftrightarrow \lambda_4 = 2l$ respectively, and so on.

$$\text{3}^{\text{rd}} \text{ overtone or 4}^{\text{th}} \text{ harmonic } f_3 = \frac{v}{\lambda_3} = \frac{4v}{2l} = 4f_o \text{ and } f_4 = \frac{v}{\lambda_4} = \frac{5v}{2l} = 5f_o$$

$$\text{In general, we can write } l = \frac{n\lambda_n}{2} \Leftrightarrow \lambda_n = \frac{2l}{n}$$

$$n^{\text{th}} \text{ Overtone or } (n+1)^{\text{th}} \text{ harmonic } f_n = \frac{v}{\lambda_n} = \frac{(n+1)v}{2l} = (n+1)f_o$$

To find the frequency f of each vibration and see that

The wave velocity in the string with its mass per unit length $\mu = \frac{m}{l}$ and

$$\text{under tension } T \text{ is given by } v = \sqrt{\frac{T}{\mu}}$$

A **normal mode** of an oscillating system is a motion in which all particles of the system move sinusoidally with the same frequency

EXAMPLE 4

A wire of length 400 mm and mass 1.2×10^{-3} kg is under a tension of 120 N. What is:

- (a) the fundamental frequency of vibration?
- (b) the frequency of the third harmonic?.

Answer

$$\text{Fundamental frequency: } f_o = \frac{1}{2 \times 400 \times 10^{-3}} \sqrt{\frac{120 \times 400 \times 10^{-3}}{1.2 \times 10^{-3}}} = 250 \text{ Hz}$$

$$\text{Third harmonic } f_2 = 3f_0 = 3 \times 250 \text{ Hz} = 750 \text{ Hz}$$

EXAMPLE 4

A wire of length 400 mm and mass 1.2×10^{-3} kg is under a tension of 120 N. What is

- (a) the fundamental frequency of vibration?
- (b) the frequency of the third harmonic?

Solution:

- (a) The fundamental frequency is obtained by substituting $n = 1$ in the equation 4.42.

$$f_1 = \frac{1}{2 \times 400 \times 10^{-3}} \sqrt{\frac{120 \times 400 \times 10^{-3}}{1.2 \times 10^{-3}}} = 250 \text{ Hz}$$

- (b) For third harmonic, using equation (4.37)

$$f_3 = 3f_1 = 3 \times 250 = 750 \text{ Hz}$$

Application Activity 4.2

Use the following descriptions in waves and fill the puzzle

Down:

- 1) The part of a longitudinal wave where the particles of the medium are close together.
- 2) A wave which needs to travel through a medium.
- 3) A repeated back-and-forth or up-and-down motion.
- 6) A wave which moves the medium in a direction across the direction the energy is traveling.
- 8) The ability to do work.

Across:

- 4) A disturbance that transfers energy from place to place.
- 5) The highest point of a wave.
- 7) The part of a longitudinal wave where the particles of the medium are far apart.
- 9) A wave which moves the medium in the same direction as the energy is traveling.
- 10) The lowest part of a transverse wave.
- 11) The material through which a wave travels.

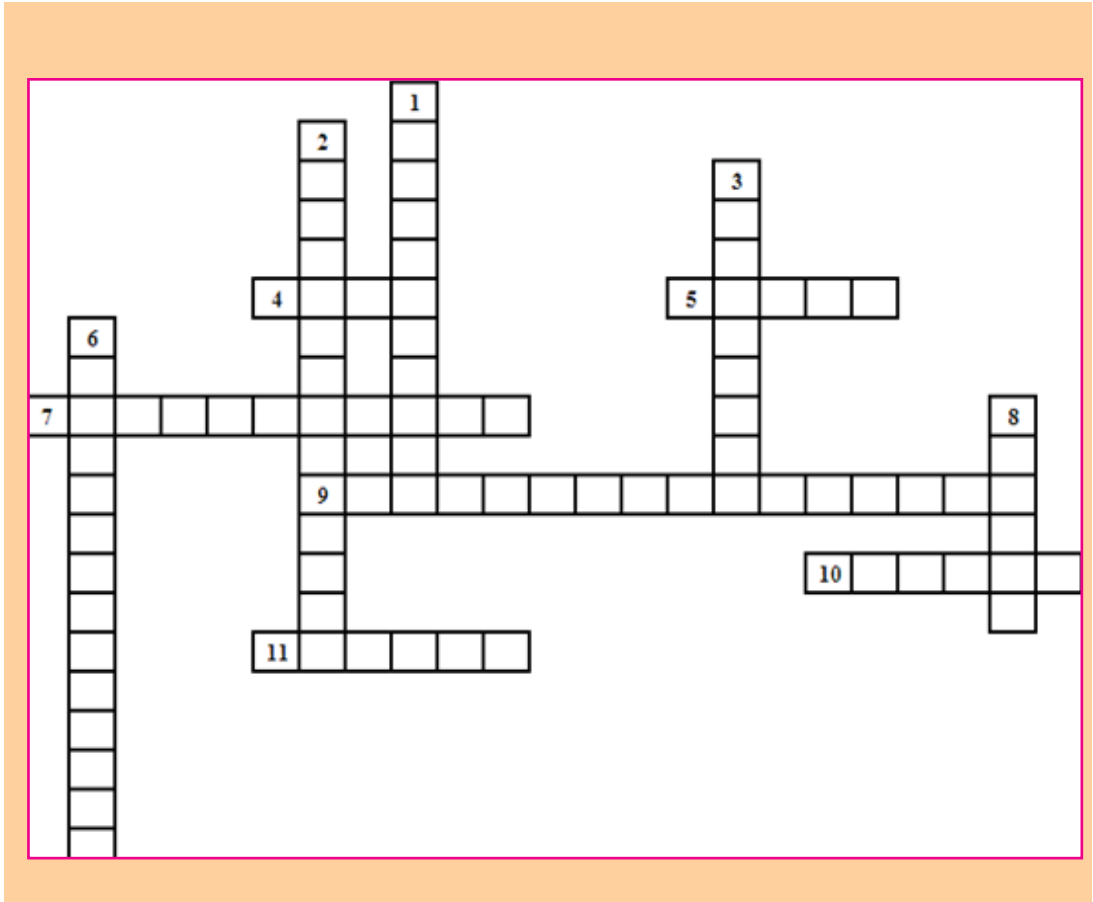

END OF UNIT PROJECT

Materials to choose from:

3 white screens, 3 biconvex lenses (), 3 biconcave lenses(), 3 biconvex mirrors(), 3 biconcave mirrors(), 3 boards with a hole, 3 laser pens, 3 big torches, 3 very bright open lamps, 1 plane mirror.

The question:

Explain how you can perform Fresnel’s diffraction and Fraunhofer diffraction in the laboratory.

Hypothesis:

Write a hypothesis about how diffraction is obtained in the lab.

Procedure

1. Decide which materials you will need (from the list) to test the hypothesis.

2. Plan your investigation.

- Which arrangements best gives the idea of diffraction?
- Which adjustments do you care to take care of?

3. Write a procedure and show it to your teacher. Do not proceed any further until it is approved.

4. Carry out your investigation.

Collecting Data

Make sure you have recorded at least the following information:

- ◇ the hypothesis
- ◇ your procedure

Analyzing and Interpreting

Share and compare your results with your classmates. Which idea is important to be used and achieve the proper arrangement of apparatus to achieve your objective?

Forming Conclusions

Make a brief report of your project with neat diagrams. In this project what is needed is the concept not the analysis of the fringes formed.

END OF UNIT ASSESSMENT

- The string shown in Figure below is driven at a frequency of 5.00 Hz. The amplitude of the motion is 12.0 cm, and the wave speed is 20.0 m/s. Determine the angular frequency and wave number k for this wave, and write an expression for the wave function.

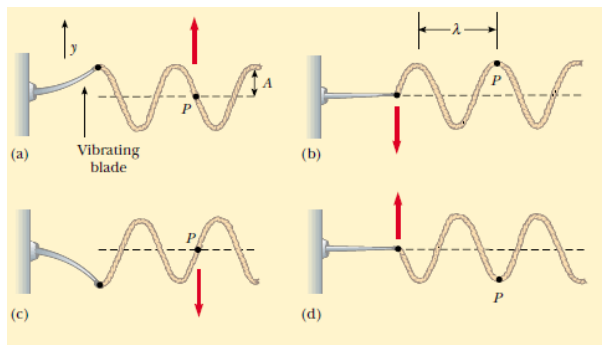

- The wave shown in Fig. below is being sent out by a 60 Hz vibrator.

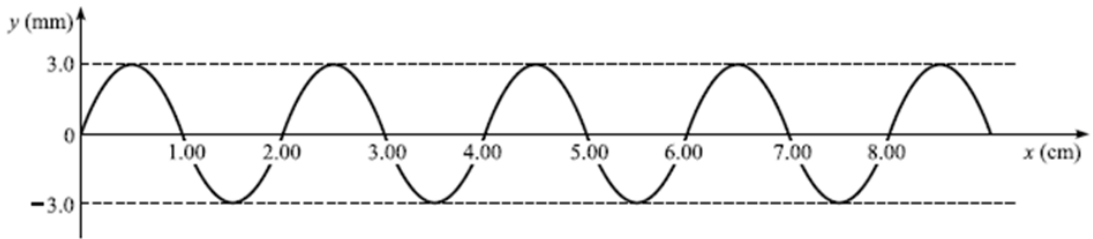

3. A string of length 3 m and mass density 0.0025 kg/m is fixed at both ends. One of its resonance frequencies is 252 Hz. The next higher resonance frequency is 336 Hz. Find the fundamental frequency and the tension in the string.
4. A wire of length 400 mm and mass 1.2×10^{-3} kg is under a tension of 120 N. What is
 - a) the fundamental frequency of vibration?
 - b) the frequency of the third harmonic?
5. A sinusoidal wave traveling in the positive x direction has an amplitude of 15.0 cm, a wavelength of 40.0 cm, and a frequency of 8.00 Hz. The vertical position of an element of the medium at $t = 0$ and $x = 0$ is also 15.0 cm, as shown in Figure below.

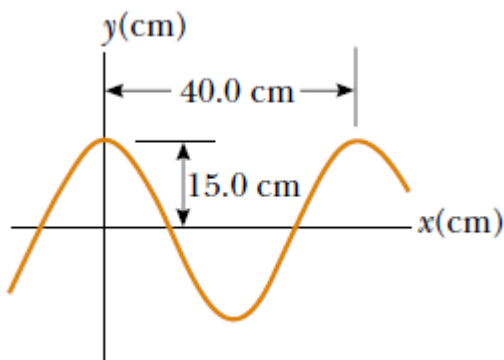

- (A) Find the wave number k , period T , angular frequency ω , and speed v of the wave.
- (B) Determine the phase constant ϕ , and write a general expression for the wave function.

UNIT SUMMARY

Waves can be defined as a disturbance in a material medium that transfers energy from one place to another.

The time **period** (T) of the wave is the time it takes for one complete vibration of the wave.

The **frequency** f is the number of wavelengths that pass a point in space in one second.

The **wavelength** λ is the horizontal distance in space between two nearest points that are oscillating in phase.

The **wave speed** v is the speed at which the wave advances.

Phase difference (phase angle) is the angular difference between two points on the wave or between two waves.

The **wave number** also called the propagation number k is the spatial frequency of a wave.

The **Intensity** of a wave or the power radiated by a source are proportional to the square of the amplitude.

Wavefront is a line or surface in the path of the wave motion on which the disturbance at every point have the same phase.

Mechanical waves are waves produced by the disturbance in a material medium.

A **progressive wave** consists of a disturbance moving from one point to another.

Longitudinal wave propagates through some medium with vibrations in the direction of propagation of the disturbance.

In **Transverse waves**, the direction of vibrations is perpendicular to the direction of propagation of the wave.

Equation of a progressive wave is given by:

$$y_p = A \sin 2\pi \left(\frac{t}{T} - \frac{x}{\lambda} \right)$$

Principle of superposition states that the resultant displacement at any time is the vector sum of the individual displacements.

Stationary waves are waves which seem to be at rest.

The positions of nodes are $x = \frac{m\lambda}{4}$ where $m = 1, 3, 5, 7, 9, \dots$

The positions of antinodes are $x = \frac{n\lambda}{2}$ where $n = 0, 1, 2, 3, 4, 5, 6, \dots$

Electromagnetic waves are disturbances in form of varying electric and magnetic fields.

All kinds of waves reflect, refract, interfere and also spread around the obstacle.

Other than the superposition of waves meeting at a point, other *conditions for interference* are:

- The sources of the waves must be coherent, which means they emit identical waves with a constant phase difference.
- The waves should be monochromatic - they should be of a single wavelength.

**UNIT
5**

INTERFERENCE OF LIGHT WAVES

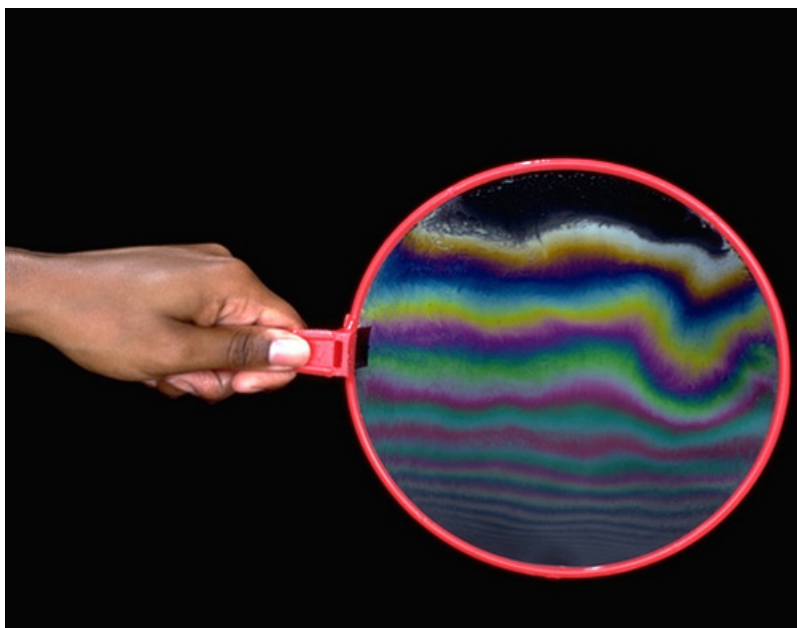

Key unit competence: Perform experiment for interference of light waves.

Unit Objectives:

By the end of this unit I will be able to;

- ◇ explain the concept of wave interferences and their applications in our daily life.
- ◇ explain the interaction of electromagnetic radiations with the earth.

Introductory Activity

Observe the diagram below and answer the questions that follow

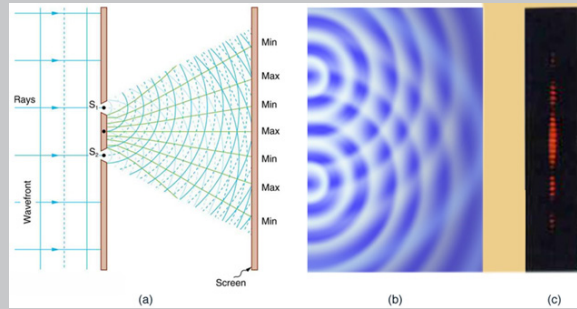

- Why do you think there are Minimum (min) and Maximum (Max) regions as indicated on the screen?
- Relating part a) and part b), what do you think lead to the formation of the patterns as indicated in b)
- What scientific phenomena, that explains the figure shown above?
- Do you think the process indicated in the figure is applicable and important in the world we live in?

5.0. INTRODUCTION

Sun is a nuclear fireball spewing energy in all directions. The light that we see is simply one part of the energy that the Sun makes that our eyes can detect. When light travels between two places (from the Sun to the Earth or from a flashlight to the sidewalk in front of you on a dark night), energy makes a journey between those two points. The energy travels in the form of waves (similar to the waves on the sea but about 100 million times smaller)—a vibrating pattern of electricity and magnetism that we call electromagnetic energy. If our eyes could see electricity and magnetism, we might see each ray of light as a wave of electricity vibrating in one direction and a wave of magnetism vibrating at right angles to it. These two waves would travel in phase and at the speed of light.

5.1. NATURE OF ELECTROMAGNETIC WAVES

Electromagnetic waves are transverse waves that transfer electrical and magnetic energy. An electromagnetic wave consists of vibrating electric and magnetic fields that move through space at the speed of light. In other words electromagnetic waves have electric and magnetic fields varying perpendicularly as shown on Fig.5.1.

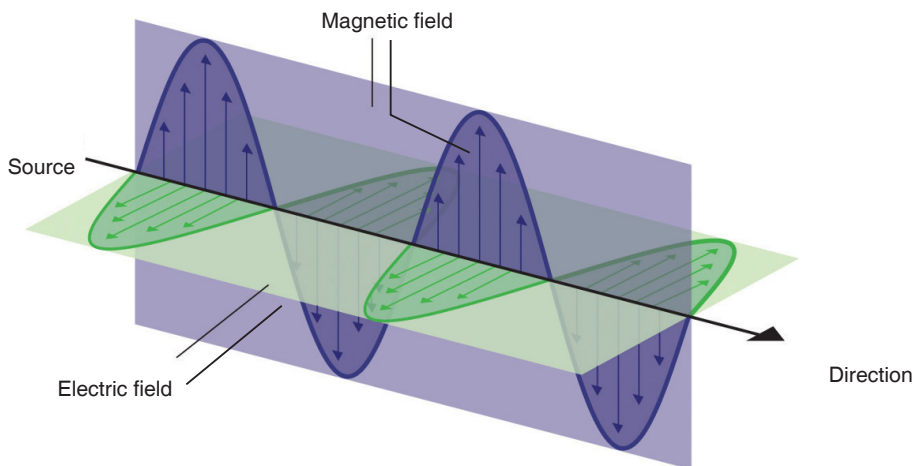

Fig. 5.1. Varying electric and magnetic fields of an electromagnetic wave.

5.1.1 Producing electromagnetic waves

Electromagnetic waves are produced by charged particles and every charged particle has an electric field surrounding it. The electric field produces electric forces that can push or pull on other particles.

When a charged particle moves, it produces a magnetic field which exerts magnetic forces that act on certain materials.

When this charged particle changes its motion, its magnetic field changes and causes the electric field to change. When one field vibrates, so does the other and the two fields constantly cause each other to change and this produces an Electromagnetic wave.

Many properties of electromagnetic waves can be explained by a wave model and some other properties are best explained by a particle model. Both a wave model and a particle model are needed to explain all of the properties of electromagnetic waves and in particular light.

5.1.2 Electromagnetic Radiation

Water waves transmit energy through space by the periodic oscillation of matter (the water). In contrast, energy that is transmitted, or radiated, through space in the form of periodic oscillations of electric and magnetic fields is known as electromagnetic radiation. In a vacuum, all forms of electromagnetic radiation—whether microwaves, visible light, or gamma rays—travel at the speed of light (c), this is about a million times faster than the speed of sound.

All forms of electromagnetic radiation consist of mutually perpendicular oscillating electric and magnetic fields. Because the electromagnetic radiations have same speed (c), they differ only in their wavelength and frequency.

5.1.3 Electromagnetic spectrum

When you tune your radio, watch TV, send a text message, or pop popcorn in a microwave oven, you are using electromagnetic energy. You depend on this energy every hour of every day. Without it, the world you know would not exist.

Electromagnetic energy travels in waves and spans a broad spectrum from very long radio waves to very short gamma rays. The human eye can only detect only a small portion of this spectrum called visible light. A radio detects a different portion of the spectrum, and an x-ray machine uses yet another portion.

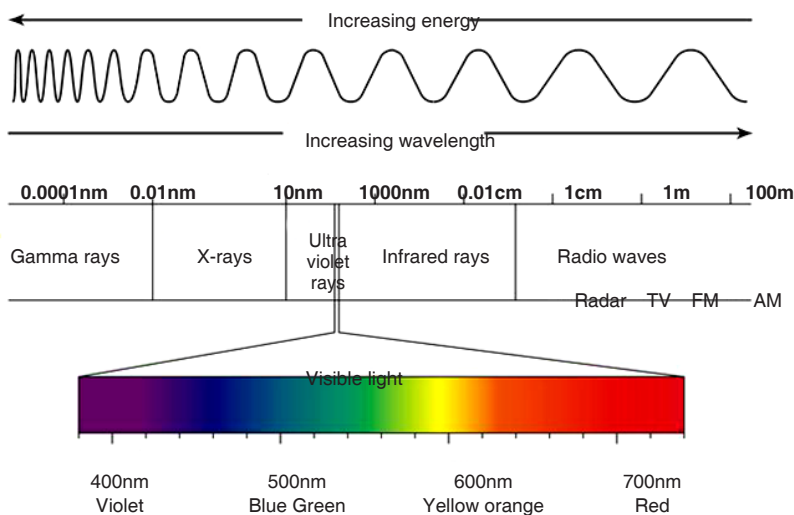

Fig. 5.2. Electromagnetic spectrum

Generation, properties and uses of those waves are summarized in the table below:

Type	Examples of generation	Main properties and uses
Gamma rays	<ul style="list-style-type: none"> Radioactive decay Nuclear fission and fusion reactions 	<ul style="list-style-type: none"> Can not be deflected by electric and magnetic fields They have high penetrating power. Have short wavelength Sterilize equipment

x-rays	Rapid deceleration of electrons	<ul style="list-style-type: none"> • Not deflected by electric and magnetic fields • They eject electrons from matter • They produce fluorescence • Can penetrate matter • They kill cancer cells
Ultraviolet	Atomic transitions e.g. in mercury vapour lamps	<ul style="list-style-type: none"> • Produce fluorescence • Increase chemical reactions • Absorbed by glass
Visible	Atomic transitions e.g. in laser, in lamps	<ul style="list-style-type: none"> • Stimulates the retina • Initiates photosynthesis
Infrared	<ul style="list-style-type: none"> • Atomic transitions • Molecular vibration 	<ul style="list-style-type: none"> • Produces heating • Used in night sights
Microwave	Magnetrons	Radar
Radio waves	Electrical oscillations	Radio communication

ACTIVITY 5-1: Spectrum of Electromagnetic Waves

Aim: In this activity, you will investigate the spectrum of visible light

Materials needed: a white sheet of paper, a glass prism and colored pencils

Shine a light through a prism so that the light leaving the prism falls on an unlined piece of paper. What colours do you see? As you hold the prism and light steady, your partner will use coloured pencils to draw the colours on the piece of paper. Switch places with your partner. Again, trace the colours you see onto the piece of paper.

◇ What colours do you see on the paper? What is the order of the colours?

◇ Is it difficult to see where one colour ends and the next begins?

◇ Did the order of the colours on the paper ever change?

◇ The term spectrum means a range. How do you think this term is related to what you observed?

5.1.4 Radiation Interaction with the Earth

Radiation that is not absorbed or scattered in the atmosphere can reach the earth and interact with its surface. There are three forms of interaction that can take place when energy strikes, or is incident upon the surface. These are: absorption (A); transmission (T); and reflection (R).

Reflection: Reflected light is perceived by our eye as colour, e.g. chlorophyll in plants reflects green light. All colours of the visible spectrum are absorbed.

Absorption: The incident energy might not get reflected or transmitted but is transformed into another form, such as heat or absorbed by chlorophyll in the process of photosynthesis.

Transmission: When energy propagates through a medium, what is not absorbed or reflected, will be transmitted through. For instance, an ultraviolet filter on a camera absorbs UV rays but allows the remaining energy to expose the film. Changes in density can also slow the velocity of light resulting in refraction such as dispersion through a prism.

5.1.5 Radiation Interaction with the Atmosphere

The Earth's atmosphere acts as a filter to remove radiations such as cosmic rays, gamma rays, X-rays, UV rays, and large portions of the electromagnetic spectrum through the process of absorption and scattering by gases, water vapour, and particulate matter (dust).

Scattering occurs when particles or large gas molecules present in the atmosphere cause the electromagnetic radiation to be redirected from its original path. There are three types of scattering which take place: Rayleigh Scattering, Mie Scattering, Non-selective Scatter.

Rayleigh scattering refers to the scattering of light off by the molecules of air. It can be extended to scattering from particles of sizes up to about one-tenth of the wavelength of the light. It is Rayleigh scattering of white light by the molecules of the air which gives us the blue sky.

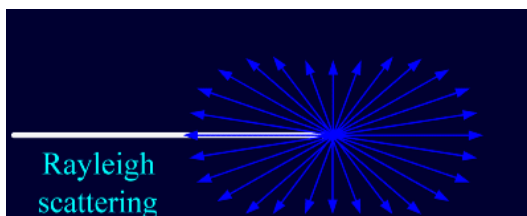

Fig. 5.3. Rayleigh scattering

Mie scattering is caused by pollen, dust, smoke, water droplets and other particles in the lower portion of the atmosphere. It occurs when the particles causing the scattering are larger than the wavelengths of radiation in contact with them. Mie scattering is responsible for the white appearance of the clouds, as seen below.

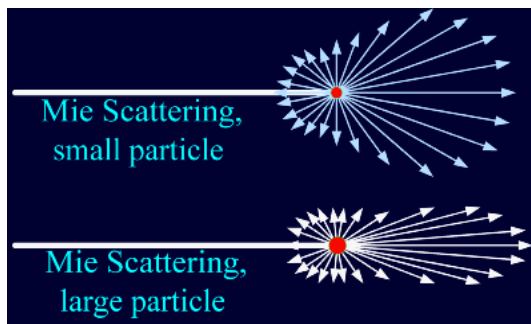

Fig. 5.4. Mie scattering

Non-Selective Scattering occurs when the particles are much larger than the wavelength of the radiation. Water droplets and large dust particles can cause this type of scattering and cause fog and clouds to appear white to our eyes because blue, green, and red light are all scattered in approximately equal quantities (blue+green+red light = white light).

5.1.6 Atmospheric Absorption of electromagnetic waves

In addition to the scattering of EM radiation, the atmosphere also absorbs electromagnetic radiation. The three main constituents of atmosphere which absorb parts of solar radiation are Ozone, Carbon dioxide, and Water Vapour.

Ozone serves to absorb the harmful ultraviolet radiations from the sun. Without this protective layer in the atmosphere, our skin would burn when exposed to sunlight. Ultraviolet rays can also cause skin cancer to people.

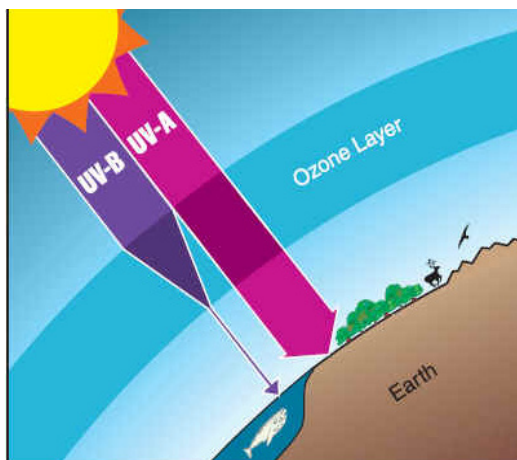

Fig. 5.5. The Ozone

Carbon Dioxide absorbs the far infrared portion of the spectrum which is related to thermal heating and results in a ‘greenhouse’ effect.

Water Vapour absorbs energy depending upon its location and concentration, and forms a primary component of the Earth’s climatic system.

5.2. CONDITIONS FOR INTERFERENCE WITH TWO SOURCES OF LIGHT

When two waves of exactly same frequency (coming from two coherent sources) travel in a medium, in the same direction simultaneously then due to their superposition, at some points intensity of light is maximum while at some other points intensity is minimum. This phenomenon is called Interference of light.

There are two types of interference: **constructive interference** and **destructive interference**.

A constructive interference is produced at a point when the amplitude of the resultant wave is greater than that of any individual wave.

A destructive interference is produced at a point when the amplitude of the resultant wave is smaller than that of any individual wave.

Conditions for interference

When waves come together they can interfere constructively or destructively. To set up a stable and clear interference pattern, two conditions must be met:

- The sources of the waves must be coherent, which means they emit identical waves with a constant phase difference.
- The waves should be monochromatic - they should be of a single wavelength.

5.3. PRINCIPLE OF SUPERPOSITION

The principle states that when two or more than two waves superimpose over each other at a common particle of the medium then the resultant displacement (y) of the particle is equal to the vector sum of the displacements (y_1 and y_2) produced by individual waves. *i.e.* $\vec{y} = \vec{y}_1 + \vec{y}_2$

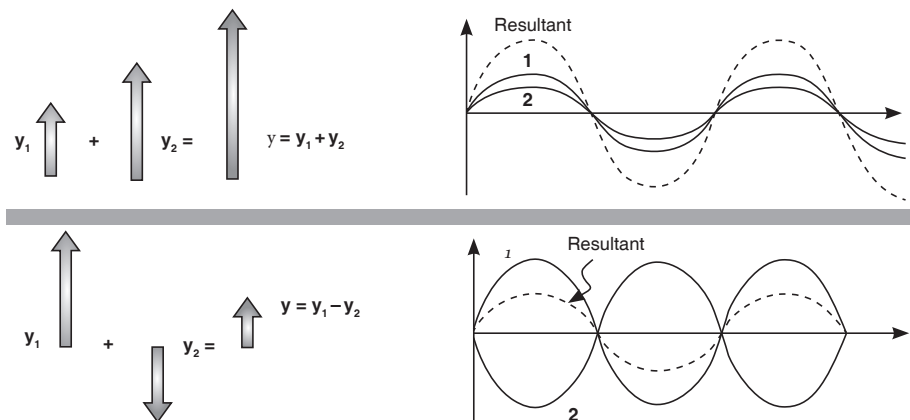

Fig. 5.6. Superposition of waves

Consider two waves given as:

$$y_1 = a_1 \sin \omega t \text{ and } y_2 = a_2 \sin (\omega t + \phi);$$

where a_1, a_2 = Individual amplitudes, ϕ = Phase difference between the waves at an instant when they are meeting a point. I_1, I_2 = Intensities of individual waves

After superimposition of the given waves resultant amplitude (or the amplitude of resultant wave) is given by;

$$A = \sqrt{a_1^2 + a_2^2 + 2a_1a_2 \cos \phi} \quad \dots\dots\dots \text{Equation 5-1}$$

Consider the displacement $y_1 = a \sin(\omega t - \Phi)$ of a progressive sinusoidal wave at time t and at a distance x from the origin and moving to right.

Consider also the displacement y_2 of an identical wave travelling in opposite direction given by

$$y_2 = a \sin(\omega t + \Phi)$$

By principal of superposition, the resultant Y is got from $Y = y_1 + y_2$

$$Y = a \sin(\omega t - \Phi) + a \sin(\omega t + \Phi)$$

$$Y = 2a \sin(\omega t) \cos \Phi$$

$$\text{but } \Phi = kx$$

$$Y = 2a \sin(\omega t) \cos kx$$

The only variable part of equation is $\sin \omega t$. This means that the amplitude of the resultant amplitude A is given by equation $A = 2a \cos kx$

EXAMPLES

1. Two waves traveling in opposite directions produce a standing wave. The individual wave functions are $y_1 = 4.0 \sin(3.0x - 2.0t)$ and $y_2 = 4.0 \sin(3.0x + 2.0t)$ where x and y are measured in centimeters.

(A) Find the amplitude of the simple harmonic motion of the element of the medium located at $x = 2.3$ cm

Answer

The standing wave is described by Equation

$$y = 2A \cos kx \sin \omega t \text{ where } k = \frac{2\pi}{\lambda}, \quad \omega = \frac{2\pi}{T}$$

in this problem, we have $A = 2.0 \text{ cm}$, $k = 3.0 \text{ rad/cm}$, and $\omega = 2.0 \text{ rad/s}$.

Thus, $y = 2A \cos kx \sin \omega t = 8.0 \cos 3.0x \sin 2.0t$

Thus, we obtain the amplitude of the simple harmonic motion of the element at the position $x = 2.3 \text{ cm}$ by evaluating the coefficient of the cosine function at this position:

$$y_m = 8.0 \cos(3.0 \times 2.3) \text{ rad} = 6.5 \text{ cm}$$

(B) Find the positions of the nodes and antinodes if one end of the string is at $x = 0$.

Answer

With $k = \frac{2\pi}{\lambda} = 3 \text{ rad/s}$,

we see that the wavelength is $\lambda = \frac{2\pi}{3}$.

Therefore, from Equation $x = \frac{2n+1}{4} \lambda$

we find that the nodes are located at $x = \frac{(2n+1)}{4} \lambda$

it follows that $x = \frac{(2n+1)\pi}{6}$

and from Equation $x = \frac{n\lambda}{2}$

we find that the antinodes are located at $x = \frac{n\lambda}{2} = \frac{n\pi}{3}$

(C) What is the maximum value of the position in the simple harmonic motion of an element located at an antinode?

Answer

The maximum position of an element at an antinode is the amplitude of

the standing wave, which is twice the amplitude of the individual traveling waves:

$$Y_{\max} = 2A \cos kx = 8.0 \cos 3.0x = 8.0 \times (\pm 1) = \pm 8.0 \text{ cm}$$

where we have used the fact that the maximum value of

5.4. INTERFERENCE PATTERN OF TWO COHERENT POINT SOURCES OF LIGHT

The sources of light which emit continuous light waves of the same wavelength, same frequency and are in same phase (or have a constant phase difference) are called **coherent sources**. Two coherent sources are produced from a single source of light by using Young's double slits.

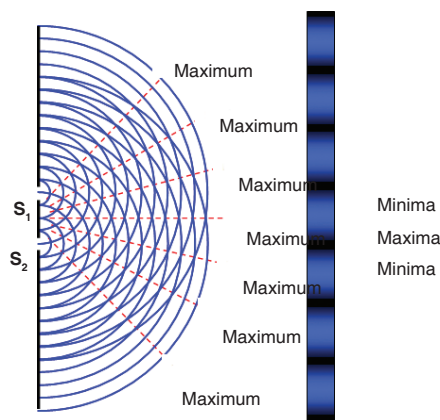

Fig. 5.7. Interference pattern of two coherent sources S_1 and S_2

From the Fig. 13.7. S_1 and S_2 are coherent sources and show interference as light passes through two slits. It also shows the appearance of the interference pattern on a screen placed in the path of the beam. You can see the maxima and minima and the way in which the intensity changes.

Changing the wavelength of the light, the separation of the slits or the distance of the slits from the screen will all give changes in the separation of the maxima in the interference pattern.

5.5. YOUNG'S DOUBLE-SLIT EXPERIMENT

Monochromatic light (single wavelength) falls on two narrow slits S_1 and S_2 which are very close together and act as two coherent sources. When waves coming from two coherent sources superimpose on each other, an interference pattern is obtained on the screen. In Young's double slit

experiment alternate bright and dark bands are obtained on the screen. These bands are called **Fringes**.

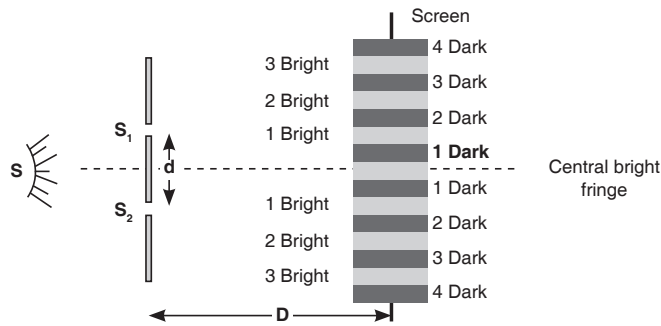

Fig. 13.8. Interference on Young's double slit experiment

Following points must be noted and observed in the above experiment:

- Central fringe is always bright, because at central position, $\phi = 0^\circ$ or the path difference $\Delta = 0$
- The fringe pattern obtained due to a slit is more bright than that due to a point.
- If the slit widths are unequal, the minima will not be completely dark. For very large slit width, uniform illumination occurs, i.e. bright and dark fringes are not formed.
- If one slit is illuminated with red light and the other slit is illuminated with blue light, no interference pattern is observed on the screen.
- If the two coherent sources consist of object and its reflected image, the central fringe is dark instead of bright one.

Calculation of fringe separation/fringe width

Consider two coherent sources (slits) S_1 and S_2 separated by distance d . The distance D from the plane of slits to the screen is much greater than d . Consider a wave from S_1 that meets another wave from S_2 at point P.

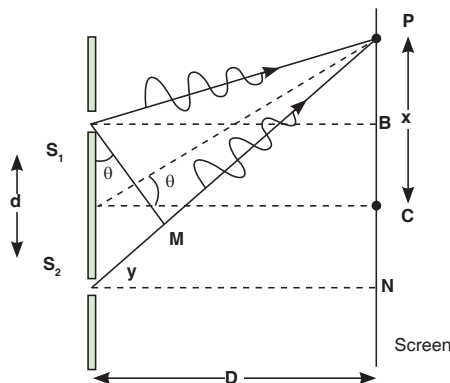

Fig. 5.9. Young's double slit experiment

From the figure, $S_2P - S_1P$ is called the path difference between waves reaching P from S_1 and S_2 .

Considering ΔS_2NP , using Pythagoras theorem;

$$(S_2P)^2 = (S_2N)^2 + (NP)^2 \quad \dots\dots\dots \text{Equation 5-2}$$

Considering ΔS_1BP , using Pythagoras theorem;

$$(S_1P)^2 = (S_1B)^2 + (BP)^2 \quad \dots\dots\dots \text{Equation 5-3}$$

Subtracting equation 5.3 from equation 5.2,

$$(S_2P)^2 - (S_1P)^2 = (S_2N)^2 + (NP)^2 - ((S_1B)^2 + (BP)^2)$$

$$(S_2P)^2 - (S_1P)^2 = (S_2N)^2 + (NP)^2 - (S_1B)^2 - (BP)^2$$

But $S_1B = S_2N$

$$(S_2P)^2 - (S_1P)^2 = (NP)^2 - (BP)^2$$

If $S_1P = r_1$ and $S_2P = r_2$, then

$$r_2^2 - r_1^2 = \left(x + \frac{d}{2}\right)^2 - \left(x - \frac{d}{2}\right)^2$$

$$r_2^2 - r_1^2 = 2xd$$

$$(r_1 + r_2)(r_2 - r_1) = 2xd$$

$$r_2 - r_1 = \frac{2xd}{r_2 + r_1} \quad \dots\dots\dots \text{Equation 5-4}$$

But if S_1 and S_2 are very close to each other,

then $r_1 + r_2 \approx 2D$

$$r_2 - r_1 = \frac{2xd}{2D}$$

The path difference is given by;

$$\Delta = \frac{xd}{D} \quad \dots\dots\dots \text{Equation 5.5}$$

Also from the figure, the path difference is calculated from;

$$\sin \theta = \frac{y}{d}$$

$$y = d \sin \theta \quad \dots\dots\dots \text{Equation 5.6}$$

Position for the dark and bright fringes

Note that a fringe is a region of net interference. A bright fringe is obtained when the path difference is a whole number of wavelength.

$$r_2 - r_1 = n\lambda \quad \text{where } n = 0, 1, 2, 3, 4, \dots$$

$$\frac{xd}{D} = n\lambda$$

$$x = \frac{n\lambda D}{d} \quad \dots\dots\dots \text{Equation 5.7}$$

A dark fringe is obtained when the path difference is an odd value of half wavelength.

$$r_2 - r_1 = \frac{m}{2}\lambda$$

$$x = \frac{m\lambda D}{2d} \quad \dots\dots\dots \text{Equation 5.8}$$

Where $m = 1, 3, 5, 7, \dots$

Example

1. A viewing screen is separated from a double-slit source by 1.2 m. The distance between the two slits is 0.030 mm. The second-order bright fringe ($m = 2$) is 4.5 cm from the center line.

- (a) Determine the wavelength of the light.
- (b) Calculate the distance between adjacent bright fringes.

Solution:

a) From equation: $x_n = \frac{m\lambda D}{d}$ with $m = 2$, $x_{\text{bright}} = 4.5 \times 10^{-2} \text{ m}$, $L = 1.2 \text{ m}$ and $d = 3.0 \times 10^{-5}$

We find $\lambda = \frac{\lambda_{\text{bright}} d}{mD} = 5.6 \times 10^{-7} \text{ m}$

b) From equation: $x_{m+1} - x_m = \frac{(m+1)\lambda D}{d} - \frac{m\lambda D}{d} = \frac{\lambda D}{d} = \frac{5.6 \times 10^{-7} \times 1.2}{3.0 \times 10^{-5}} = 2.2 \text{ cm}$

Notes

- x is fringe separation and its value increases by decreasing the slit separation α .

$$x \propto \frac{1}{d} \quad \dots\dots\dots \text{Equation 5.9}$$

- Increasing the width of the slits increases the intensity of waves and fringes become more blurred.

Application Activity 5.2

1. What is the necessary condition on the path length difference between two waves that interfere (a) constructively and (b) destructively?
2. If Young's double-slit experiment were performed under water, how would the observed interference pattern be affected?
3. In Young's double-slit experiment, why do we use monochromatic light? If white light is used, how would the pattern change?
4. The distance between the two slits is 0.030 mm . the second-order bright fringe ($m = 2$) is measured on a viewing screen at an angle of 2.15° from the central maximum. Determine the wavelength of the light.
5. A 2-slit experiment is set up in which the slits are 0.03 m apart. A bright fringe is observed at an angle 10° from the normal. What is wavelength of electromagnetic radiation being used?
6. In Young's double slit experiment the separation between the 1st and 5th bright fringes is 2.5 mm . When the wavelength used is $6.2 \times 10^{-7}\text{ m}$. The distance from the slits to screen is 0.8 m . Calculate the separation of the slits

5.6. INTENSITY DISTRIBUTION OF FRINGE PATTERN

So far we have discussed the locations of only the centers of the bright and dark fringes on a distant screen. We now direct our attention to the intensity of the light at other points between the positions of maximum constructive and destructive interference. In other words, we now calculate the distribution of light intensity associated with the double-slit interference pattern.

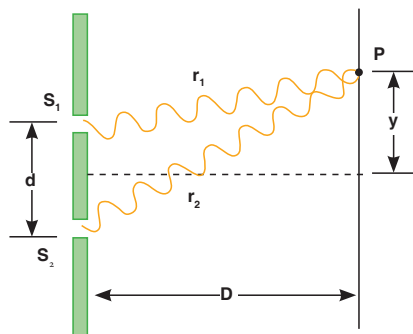

Fig. 5.11. Waves meeting at point P

Again, suppose that the two slits represent coherent sources of sinusoidal waves such that the two waves from the slits have the same angular frequency ω and a constant phase difference Φ . The total magnitude of the electric field at point P on the screen is the vector superposition of the two waves. Assuming that the two waves have the same amplitude E_0 , we can write the magnitude of the electric field at point P due to each wave separately as;

$$E_1 = E_0 \sin \omega t \text{ and } E_2 = E_0 \sin(\omega t + \Phi)$$

Although the waves are in phase at the slits, their phase difference Φ at point P depends on the path difference $y = r_2 - r_1 = d \sin \theta$.

So from;

$$y = d \sin \theta \quad \text{and} \quad \Phi = \frac{2\pi y}{\lambda}$$

$$\Phi = \frac{2\pi d \sin \theta}{\lambda} \quad \dots\dots\dots \text{Equation 5-10}$$

The resultant electric field at point P is given by;

$$E_p = E_0(\sin \omega t + \sin(\omega t + \Phi))$$

$$E_p = 2E_0 \cos\left(\frac{\Phi}{2}\right) \sin\left(\omega t + \frac{\Phi}{2}\right) \quad \dots\dots\dots \text{Equation 5-11}$$

This result indicates that the electric field at point P has the same frequency ω as the light at the slits, but that the amplitude of the field is multiplied by the factor $2 \cos\left(\frac{\Phi}{2}\right)$.

Finally, to obtain an expression for the light intensity at point P, the intensity of a wave is proportional to the square of the resultant electric field magnitude at that point;

$$I \propto E_p^2$$

$$I = 4E_0^2 \cos^2\left(\frac{\Phi}{2}\right) \sin^2\left(\omega t + \frac{\Phi}{2}\right) \quad \dots\dots\dots \text{Equation 5.12}$$

Most light-detecting instruments measure time-averaged light intensity, and the time-averaged value of $(8\pi t + \frac{\pi}{4})$ over one cycle is $\frac{1}{2}$. Therefore, we can write the average light intensity at point P as;

$$I = I_{\max} \cos^2\left(\frac{\Phi}{2}\right) \quad \dots\dots\dots \text{Equation 5.13}$$

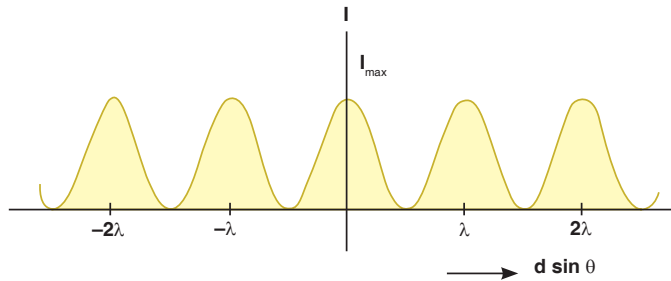
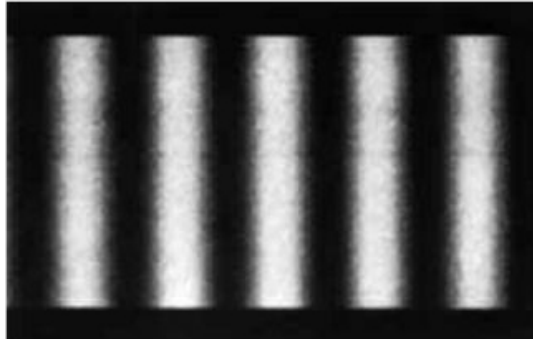

Fig. 5.12. Intensity distribution of fringe pattern

Note that the interference pattern consists of equally spaced fringes of equal intensity. Remember, however, that this result is valid only if the slit-to-screen distance D is much greater than the slit separation d .

Application Activity 5.3

1. In a double slit interference experiment, the distance between the two slits is 0.0005m and the screen is 2 m from the slits. Yellow light from a sodium lamp is used and it has a wavelength of $5.89 \times 10^{-7}\text{ m}$. Show that the distance between the first and second fringes on the screen is 0.00233 m .
2. With two slits are spaced 0.2 mm apart, and a screen at a distance of $D = 1\text{ m}$, the third bright fringe is found to be displaced $h = 7.5\text{mm}$ from the central fringe. Show that the wavelength, λ , of the light used is $5 \times 10^{-7}\text{ m}$.
3. Two radio towers are broadcasting on the same frequency. The signal is strong at A, and B is the first signal minimum. If $d = 6.8\text{ km}$, $L = 11.2\text{ km}$, and $y = 1.73\text{ km}$, what is the wavelength of the radio waves to the nearest meter?

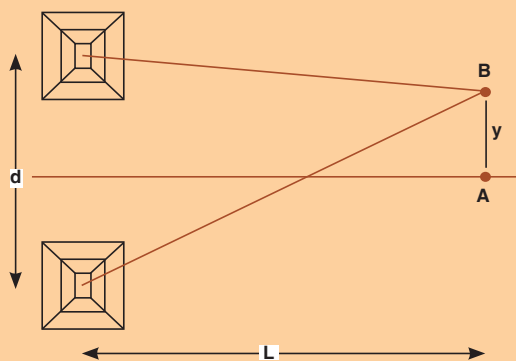

Fig. 5.13. Interference of waves from two radio towers

4. Water waves of wavelength of 5.44 m are incident upon a breakwater with two narrow openings separated by a distance 247 m. To the nearest thousandth of a degree, what is angle corresponding to the first wave fringe maximum?

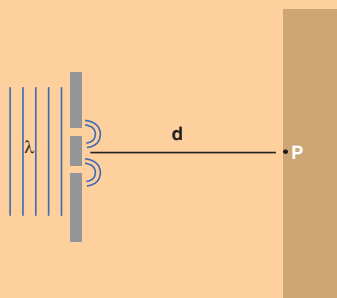

Fig. 5.14. A breakwater with two narrow openings

UNIT SUMMARY

Nature of electromagnetic waves

Electromagnetic waves are transverse waves that transfer electrical and magnetic energy.

In other words electromagnetic waves have electric and magnetic fields varying perpendicularly.

Producing electromagnetic waves

Electromagnetic waves are produced by charged particles and every charged particle has an electric field surrounding it. The electric field produces electric forces that can push or pull other particles.

Electromagnetic Radiation

All forms of electromagnetic radiation consist of perpendicularly oscillating electric and magnetic fields. Various kinds of electromagnetic radiations have the same speed (c). They differ only in wavelength and frequency.

Electromagnetic energy travels in waves and spans a broad spectrum from very long radio waves to very short gamma rays. This is called **electromagnetic spectrum**.

From memory you should be able to list the parts in order of energy (relate how that relates to frequency and wavelength) and know how they are produced, detected and their dangers and uses - a rough idea of their approximate wavelength is also useful!

Radiation Interaction with the Earth

Radiation that is not absorbed or scattered in the atmosphere can reach and interact with the Earth's surface. There are three forms of interaction that can take place when energy strikes, or is incident upon the surface. These are: absorption (A), transmission (T) and reflection (R).

Radiation Interaction with the Atmosphere

The Earth's atmosphere acts as a filter to remove radiation such as cosmic rays, gamma rays, X-rays, UV rays and large portions of the electromagnetic spectrum through the process of absorption and scattering by gases, water vapour and particulate matter (dust).

Atmospheric Absorption of electromagnetic waves

In addition to the scattering of EM radiation, the atmosphere also absorbs electromagnetic radiation. The three main constituents which absorb radiation are Ozone, Carbon Dioxide and Water Vapour.

Conditions for interference to occur

- The sources of the waves must be coherent, which means they emit identical waves with a constant phase difference.
- The waves should be monochromatic - they should be of a single wavelength.

Principle of superposition

The principle states that when two or more than two waves superimpose over each other at a common particle of the medium then the resultant displacement (y) of the particle is equal to the vector sum of the displacements (y_1 and y_2) produced by individual waves. *i.e.* $\vec{y} = \vec{y}_1 + \vec{y}_2$

Double-slit experiment

Monochromatic light (single wavelength) falls on two narrow slits S_1 and S_2 which are very close together acts as two coherent sources, when waves coming from two coherent sources superimposes on each other, an interference pattern is obtained on the screen

A bright fringe is obtained when the path difference is a whole number of wavelength.

$$r_2 - r_1 = n\lambda \quad \text{where } n = 0, 1, 2, 3, 4, \dots$$

A dark fringe is obtained when the path difference is an odd value of half wavelength.

$$r_2 - r_1 = \frac{m}{2}\lambda$$

$$x = \frac{m\lambda D}{2d}$$

Where $m = 1, 3, 5, 7, \dots$

Intensity distribution of fringe pattern

Assuming that the two waves have the same amplitude E_0 , we can write the magnitude of the electric field at a point let say P due to each wave separately as;

$$E_1 = E_0 \sin \omega t \quad \text{and} \quad E_2 = E_0 \sin(\omega t + \Phi)$$

Since $I \propto E_p^2$, we can write the average light intensity at point P as;

$$I = I_{\max} \cos^2 \left(\frac{\Phi}{2} \right)$$

$$I = I_{\max} \cos^2 \left(\frac{\pi d \sin \theta}{\lambda} \right)$$

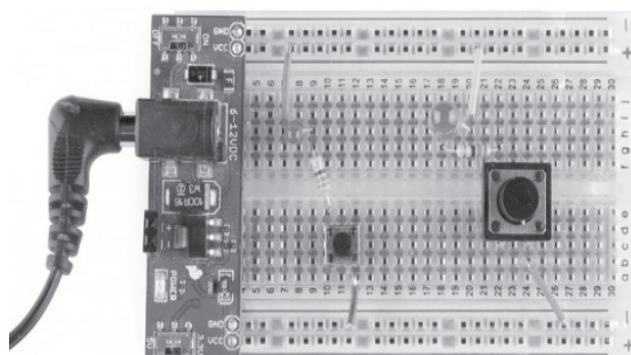
**UNIT
6****COMPLEX ELECTRICAL
CIRCUIT**

Key topic competence: By the end of the unit I should be able to construct and to analyze a complex electrical circuit.

UNIT OBJECTIVES:

By the end of this unit, I should be able to:

- ◇ analyse complex electrical circuits well.
- ◇ use Kirchhoff's laws in circuit analysis accurately
- ◇ analyse simple potentiometer circuits clearly.

Introductory Activity



Look at the illustration given above.

- What type of devices available in the illustration above?
- Can you suggest the names of the available devices in the illustration above?
- Is there any complete circuit in the illustration above?
- What kind of electrical circuits identified in the illustration above?
- Have you ever used or connected these electrical components somewhere? If yes, what were the difficulties in handling these electrical components in circuit construction?
- What can be considered to select the best electrical device(s) to be used in electrical circuit construction?
- What can be put in recognition to minimize risks when connecting these electrical components in the circuit?

6.0 INTRODUCTION

A complex circuit configuration is one that contains components that are connected either in parallel or in series with each other. If a circuit can be reduced to a single resistor, it is a series or parallel circuit. If not, it is a complex circuit. If the circuit is complex and is mixed with series and parallel networks of resistors and supplies, we may want to look if it is feasible to reduce these to a single power supply and a single resistor which would make them either a series or a parallel simple circuit.

Most electronic devices we use at home have built-in complex circuits to perform different tasks. Also the concept of this unit is helpful in other subjects like electrons and conductors (in Chemistry), volume adjustment circuits in radios.

Opening questions

1. A combination circuit is shown in the diagram of Fig.5.1. Use the diagram to answer the following questions.
 - a. The current at location A is _____ (greater than, equal to, less than) the current at location B.
 - b. The current at location B is _____ (greater than, equal to, less than) the current at location E.
 - c. The current at location G is _____ (greater than, equal to, less than) the current at location F.
 - d. The current at location E is _____ (greater than, equal to, less than) the current at location G.
 - e. The current at location B is _____ (greater than, equal to, less than) the current at location F.
 - f. The current at location A is _____ (greater than, equal to, less than) the current at location L.
 - g. The current at location H is _____ (greater than, equal to, less than) the current at location I.

2. Consider the combination circuit in the diagram of Fig.5.1. Use the diagram to answer the following questions. (Assume that the voltage drop in the wires is negligibly small.)
 - a. The electric potential difference (voltage drop) between points B and C is _____ (greater than, equal to, less than) the electric potential difference (voltage drop) between points J and K.
 - b. The electric potential difference (voltage drop) between points B and K is _____ (greater than, equal to, less than) the electric potential difference (voltage drop) between points D and I.
 - c. The electric potential difference (voltage drop) between points E and

- F is _____ (greater than, equal to, less than) the electric potential difference (voltage drop) between points G and H.
- d. The electric potential difference (voltage drop) between points E and F is _____ (greater than, equal to, less than) the electric potential difference (voltage drop) between points D and I.
- e. The electric potential difference (voltage drop) between points J and K is _____ (greater than, equal to, less than) the electric potential difference (voltage drop) between points D and I.
- f. The electric potential difference between points L and A is _____ (greater than, equal to, less than) the electric potential difference (voltage drop) between points B and K.

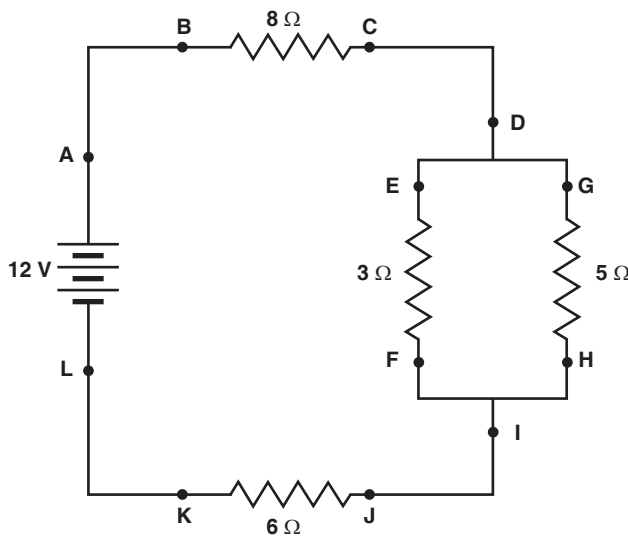

Fig. 6.1; Mixed network of resistors

6.1 KIRCHHOFF'S LAWS

Next to Ohm's Law in the fundamental rules which govern the behaviour of electric circuits are Kirchhoff's Circuit Laws. Gustav Kirchhoff in 1845 formulated two circuit laws, one of which essentially establishes the conservation of charge and the other establishes the conservation of potential.

ACTIVITY 6-1

The 16 puzzle pieces associated with this problem represent different circuit elements. Arrange the circuit pieces to form a four-by-four-piece square, with the “sun” symbol appearing somewhere within the puzzle. If all of the puzzle pieces are placed appropriately, the sun will be in a specific position.

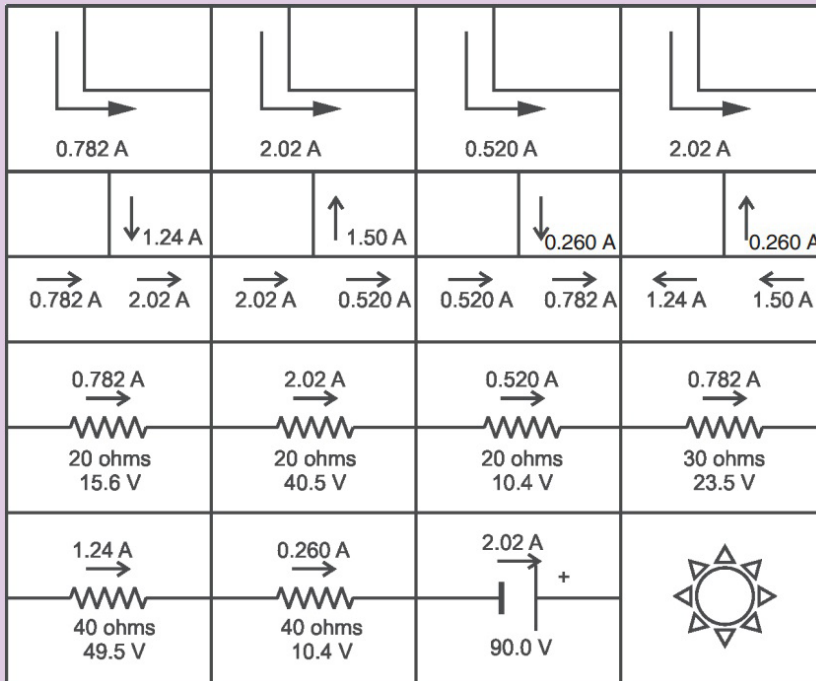

Fig.6.2; Kirchhoff's law puzzle

6.1.1 Kirchhoff's Current Law

Kirchhoff's first law, known as Kirchhoff's Current Law (KCL) or Kirchhoff's Junction Rule, essentially expresses the conservation of charge, which can be thought of as the conservation of matter. This implies that charge cannot appear from anything at any point in a circuit, neither can it disappear into oblivion at any point.

Kirchhoff's Current Law states that “the algebraic sum of the currents flowing at a node or junction in an electric circuit is zero”.

This means that currents are added with respect to their directions. Let us consider the junction shown on Fig. 6.3 below.

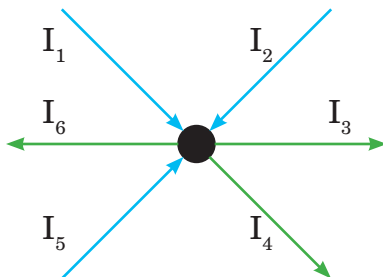

Fig.6.3; A circuit node with several associated currents

From the figure;

$$\Sigma I = 0$$

$$I_1 + I_2 - I_3 - I_4 + I_5 - I_6 = 0$$

$$I_1 + I_2 + I_5 = I_3 + I_4 + I_6 \quad \dots\text{Equation 6.1}$$

Note that both forms are completely mathematically consistent.

EXAMPLE 6.1

In the circuit of Fig. 5.4, the magnitudes of the currents are as follows:

$I_1 = 2.5 \text{ A}$, $I_2 = 4 \text{ A}$, $I_4 = 7.5 \text{ A}$, $I_6 = 6 \text{ A}$ and $I_3 = 2I_5$. Determine the values of I_3 .

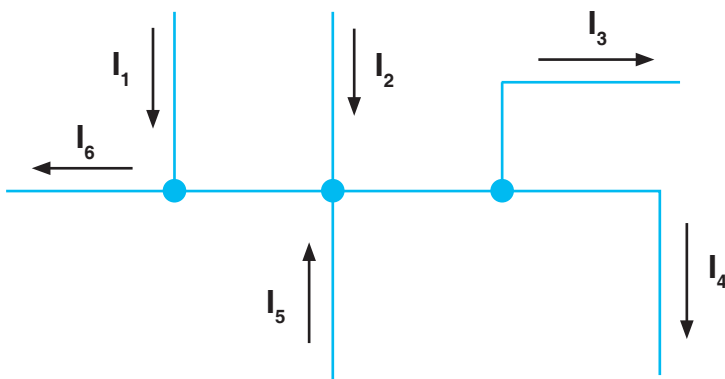

Fig.6.4; Current at circuit nodes

Solution: Using Kirchhoff's Current Law,

$$-I_6 + I_1 + I_2 - I_3 - I_4 + I_5 = 0$$

$$-6 + 2.5 + 4 - 2I_5 - 7.5 + I_5 = 0 \Rightarrow I_5 = -7 \text{ A}$$

$$I_3 = 2I_5 = 2 \times (-7 \text{ A}) = -14 \text{ A}$$

Notes: Any calculated value of current which works out to be negative simply indicates that in practice, the current is actually flowing in a direction opposite to that assigned in the schematic diagram of the circuit.

6.1.2 Kirchhoff's Voltage Law

Kirchhoff's second circuit law, known as Kirchhoff's Voltage Law (KVL) or Kirchhoff's Loop Rule, essentially formulates the conservation of energy in the form of electric potential around a circuit in which current is flowing. This means that no net voltage can be created or destroyed around the loop of a closed circuit.

Kirchhoff's Voltage Law states that “the algebraic sum of the potentials around a closed electric circuit is zero.”

Consider an electrical network shown in Fig. 6.5 below.

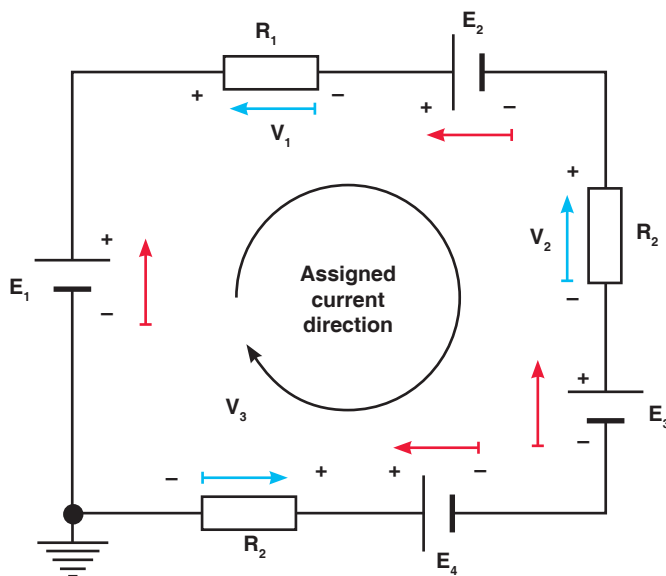

Fig. 6.5; Kirchhoff's Voltage Law applied to a closed circuit

Kirchhoff's Voltage Law gives:

$$\begin{aligned} \Sigma V &= 0 \\ E_1 - V_1 - E_2 - V_2 - E_3 + E_4 - V_3 &= 0 \\ E_1 - E_2 - E_3 + E_4 &= V_1 + V_2 + V_3 \end{aligned} \quad \dots \text{Equation 6.2}$$

Sign conventions

- The potential change across a resistor is $-IR$ if the loop is traversed along the chosen direction of current (potential drops across a resistor).
- The potential change across a resistor is $+IR$ if the loop is traversed opposite the chosen direction of current.
- If an emf source is traversed in the direction of the emf, the change in potential is positive.
- If an emf source is traversed in the opposite direction of the emf, the

change in potential is negative.

EXAMPLE 6.2

In the circuit of Fig.5.5, the magnitudes of the potentials are as follows: $E_1 = 12\text{V}$, $E_2 = 2\text{V}$, $E_3 = 5\text{V}$, $E_4 = 4.5\text{V}$, $V_1 = 2\text{V}$, and $V_2 = 2\text{V}$. Determine the values of the potentials V_2 and V_3 .

Solution: Using Kirchhoff's Voltage law gives:

$$E_1 - V_1 - E_2 - V_2 - E_3 + E_4 - V_3 = 0$$

$$12 - 2 - 2 - V_2 - 5 + 4.5 - V_3 = 0$$

$$12 - 2 - 2 - 5 + 4.5 = V_2 + V_3$$

$$V_2 + V_3 = 7.5 \text{ V}$$

$$3V_3 = 7.5 \text{ V}$$

$$\therefore V_3 = 2.5 \text{ V}$$

$$V_2 = 2 V_3 = 5 \text{ V}$$

6.2 DESIGN OF COMPLEX AND SIMPLE ELECTRIC CIRCUITS

An *electric circuit* is a collection of electrical components connected by conductors. A simple electric circuit consists of a supply with either series or parallel network of resistors.

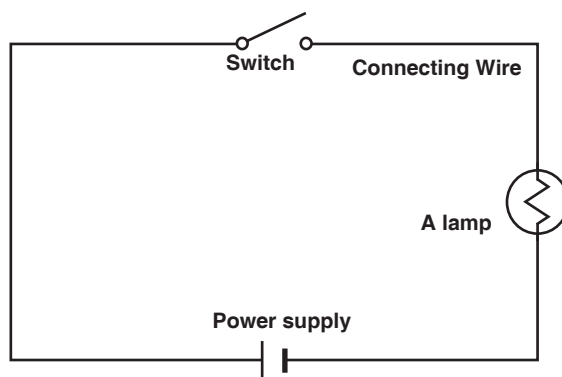

Fig.6.6; Simple electric circuit

This circuit contains neither simple series nor simple parallel connections. It contains elements of both. It is complex circuit because the circuit is a combination of both series and parallel, we cannot apply the rules for voltage, current and resistance “across the table” to begin its analysis. This is shown below;

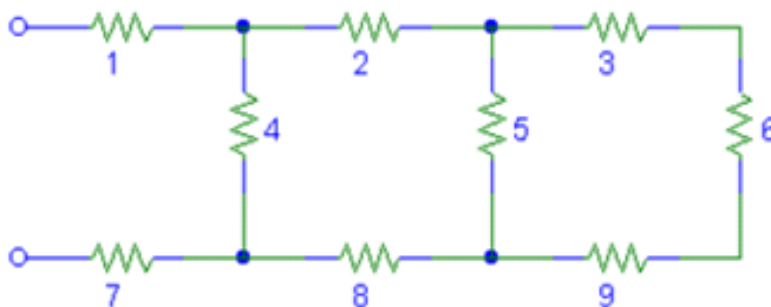

Fig.6.7; Complex electric circuit

ACTIVITY 6-2

- | | |
|---|----------------------|
| A. A circuit with two or more branches for the current to flow | 1. Electric charge |
| B. A material that electrons can move through | 2. Insulator |
| C. Flow of electrons through a conductor | 3. Conductor |
| D. Made up of series and parallel circuits | 4. Electroscope |
| E. Device to break a circuit | 5. Electric current |
| F. Poor conductor of electricity | 6. Resistance |
| G. Unit for measuring rate of electron flow in a circuit | 7. Battery |
| H. Having too many or too few electrons | 8. Circuit |
| I. A temporary source of electric current | 9. Series circuit |
| J. Rate at which a device converts electrical energy to another form of energy. | 10. Parallel circuit |
| | 11. Complex circuit |
| | 12. Volt |
| | 13. Ampere |
| | 14. Switch |
| | 15. Power |

- K. Path of electric conductors
- L. Electric charge built up in one place
- M. Device that detects electric charges
- N. Opposition to the flow of electricity
- O. Electric circuit where current flows through all parts of the circuit
- P. Unit to measure electric potential

Aim: to know different components of the circuit and why they are needed in the circuit.

Instructions: match the following terms are used in electric circuits

ACTIVITY 6-3

For each of the following circuits state if it is series, parallel or complex if any. In each case comment on the current flowing and the brightness of the bulb.

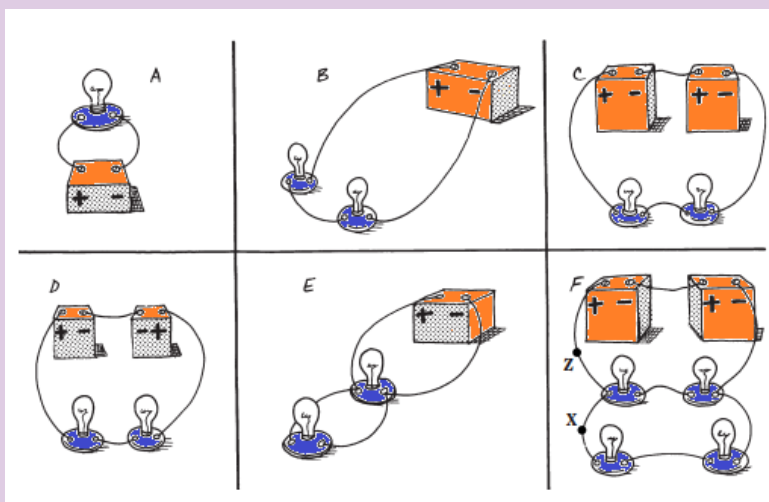

6.3 RESISTORS AND ELECTROMOTIVE FORCES IN SERIES AND PARALLEL COMPLEX CIRCUITS

This section examines how Kirchhoff's voltage and current laws are applied to the analysis of complex circuits. In the analysis of such series-parallel circuits, we often simplify the given circuit to enable us to clearly see how the rules and laws of circuit analysis apply. We might need to redraw circuits whenever the solution of a problem is not immediately apparent.

Resistors are said to be in series if they are arranged side by side in a such way that the total potential difference is shared by all resistors and the current flowing through them is the same. This arrangement is shown below:

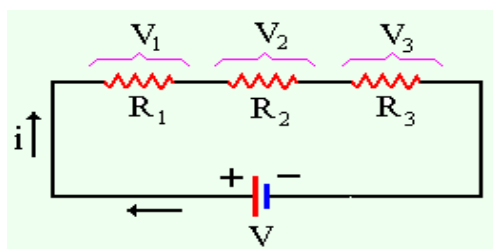

Fig.6.8; Resistors in series

A parallel circuit is a circuit in which the resistors are arranged with their heads connected together, and their tails connected together. The current in a parallel circuit breaks up, with some flowing along each parallel branch and re-combining when the branches meet again. The voltage across each resistor in parallel is the same.

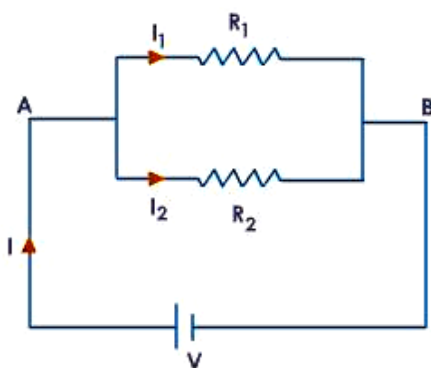

Fig.6.9; Resistors in parallel

The same idea of series and parallel resistors is applied in series and parallel cells. For series e.m.fs the total e.m.f is equivalent to the sum of individual e.m.fs with respect to the direction of currents they generate.

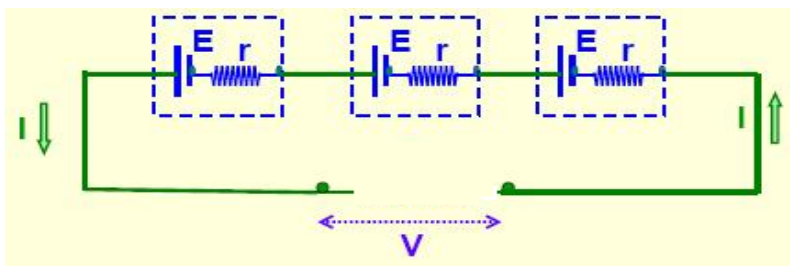

Fig.6.10; *E.m.fs in series*

When these cells are connected in parallel, the total e.m.f is equivalent to the e.m.f of only one cell.

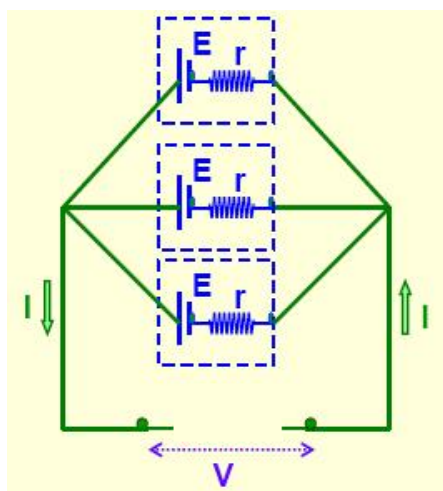

Fig.6.11 *E.m.fs in Parallel*

To solve the resistor circuits using Kirchhoff's rules,

1. Define the various currents
 - This can be done by either defining branch (segment) currents for each element in the circuit, or defining loop currents for each loop in the circuit.
2. If using branch currents, use Kirchhoff's Junction Rule to look for interdependent currents. This allows for reducing the number of variables being solved for.
3. Use Loop Rule to define voltage equations for each loop, using previously defined currents.
4. Solve set of simultaneous equations using algebraic manipulation.

EXAMPLE 6.3

Using Kirchhoff's rules, calculate the currents I_1 , I_2 and I_3 in the three branches of the circuit in Fig.5.12.

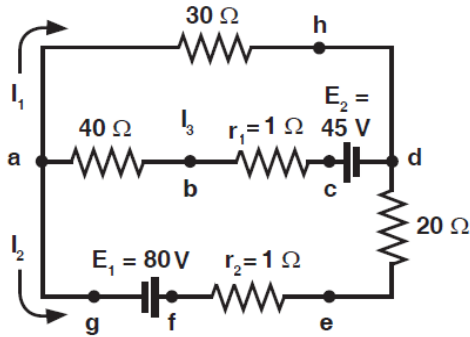

Fig. 6.12; Calculating branch currents using Kirchhoff's rules

Solution: Using junction rule;

At junction a ; $I_3 = I_1 + I_2$

Using the loop rule in loop $ahdcba$.

$$\begin{aligned}
 I_3(40 + 1) + 30 I_1 &= 45 \\
 (I_1 + I_2)(40 + 1) + 30 I_1 &= 45 \\
 71I_1 + 41I_2 &= 45 \qquad \dots\text{Equation 6.3}
 \end{aligned}$$

In loop $agfedcba$, $I_3(40 + 1) + I_2(20 + 1) = 80 + 45$

$$\begin{aligned}
 (I_1 + I_2)(40 + 1) + I_2(20 + 1) &= 80 + 45 \\
 41I_1 + 62I_2 &= 125 \qquad \dots\text{Equation 6.4}
 \end{aligned}$$

Solving equations 6.3 and 6.4 simultaneously gives;

$$I_1 = -0.87 \text{ A}$$

$$I_2 = 2.6 \text{ A}$$

$$I_3 = 1.7 \text{ A}$$

Ammeter

An ammeter is a device which is used to measure electric current flowing through a branch of a circuit. Electric current is measured in amperes (A). Smaller currents are measured by milliammeters (mA) and microammeters (μA). Ammeters are of various types—moving coil ammeter, moving magnet ammeter, moving iron ammeter, hot wire ammeter, etc. Nowadays, digital ammeters are used to measure current accurately which use ADC (analog to digital converter). An ammeter is connected in series with the circuit through which current is flowing.



Fig. 6.13; Ammeter

Voltmeter

A voltmeter is a device which is used to measure electric potential difference between two points in an electrical circuit. Electric p.d. is measured in along a calibrated scale in proportion to circuit voltage. Digital voltmeters are now frequently used to give a display of voltage using ADC. A voltmeter is always connected in parallel to the component across which p.d. is to be measured.

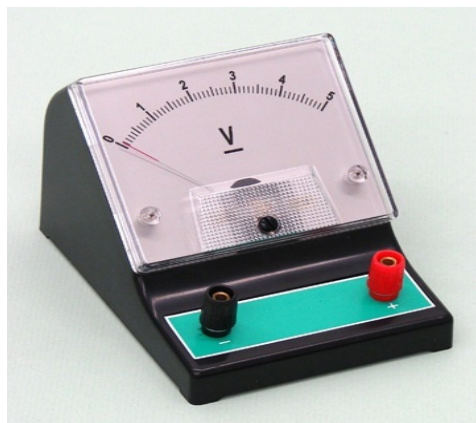

Fig. 6.14; Voltmeter

6.4 SIMPLE POTENTIOMETER CIRCUITS

A simple potentiometer is a device used for taking a number of electrical measurements. It is a piece of resistance wire, usually a metre long, fixed between two points A and B with a cell of output voltage, V , connected between the two ends. The potential difference to be measured is put into a circuit together with an opposing variable p.d. from the voltage divider.

The voltage divider is then adjusted until its p.d., V_{AC} equals the p.d. being measured. Fig. 6.15 illustrates this.

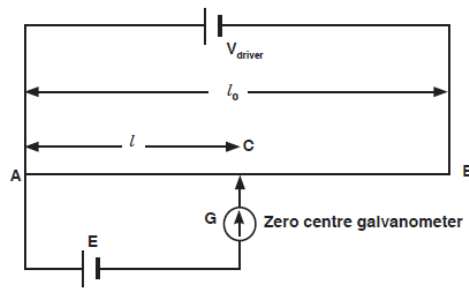

Fig.6.15; Potentiometer wire at balance point

The sliding contact in the above diagram is moved until the galvanometer indicates zero. This position is referred to as the balance point. The current in the lower part of the circuit is zero because the p.d., V_{AC} equals the p.d. E provided by the cell under test. The protective resistor serves only to prevent the galvanometer from the damage.

Electromotive force of the wire is always proportional to the length of the wire. So, the approximate value of E is determined as follows:

$$E \propto l$$

$$E = kl \quad \dots \text{Equation 6.5}$$

$$V_{\text{driver}} \propto l_0$$

$$V_{\text{driver}} = kl_0 \quad \dots \text{Equation 6.6}$$

Dividing equation 5.5 by equation 5.6 gives;

$$\frac{E}{V_{\text{driver}}} = \frac{kl}{kl_0}$$

$$\therefore E = \frac{V_{\text{driver}} \times l}{l_0} \quad \dots \text{Equation 6.7}$$

EXAMPLE 6.4

A potentiometer is set up as shown in the Fig.5.16 and the balance point for the unknown e.m.f., E is found at 84 cm from the left hand end of the meter wire. If the driver cell has e.m.f. of 1.5V and negligible internal resistance, find the value of unknown e.m.f.

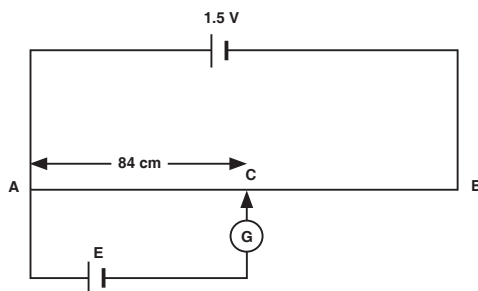

Fig. 6.16; Potentiometer wire

Solution: From Fig.6.14,

$$V_{\text{driver}} = 1.5 \text{ V}, l = 84 \text{ cm}, l_0 = 100 \text{ cm. Using equation 5.7;}$$

$$E = \frac{V_{\text{driver}} \times l}{l_0} = \frac{1.5 \times 84}{100} = 1.26 \text{ V}$$

EXAMPLE 6.5

What value of resistance is needed in series with a driver cell of negligible internal resistance and approximately 3V e.m.f. to arrange that $\frac{2}{3}$ of the 6Ω slide wire is required to balance a p.d. of 1.5V?

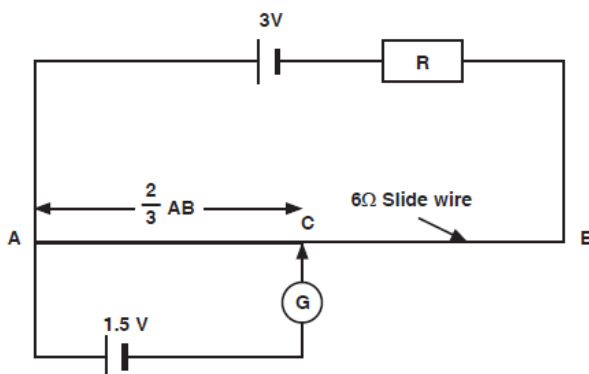

Fig.6.17; Use of the potentiometer to determine the unknown resistance

Solution: At the balance point or null point, no current flows through the galvanometer, i.e. in the lower loop of the circuit. But in the lower loop of the circuit, a current I flows. Since the current in the lower loop is zero.

$$V_{AC} = 1.5\text{V} = \frac{2}{3} V_{AB}$$

$$V_{AB} = \frac{3 \times 1.5}{2} = 2.25 \text{ V}$$

And

$$I = \frac{V_{AB}}{R_{AB}} = \frac{2.25}{6} = 0.375 \text{ A}$$

From

$$E = I \times R_{\text{total}}$$

$$3 = 0.375 \times (R + 6) \quad [\text{At balance point}]$$

So

$$R = 2 \Omega$$

6.4.1 Comparison of e.m.f.s

A potentiometer may sometimes be used to compare e.m.f's of a cell with that of a standard cell. Consider the circuit of Fig. 6.18 below.

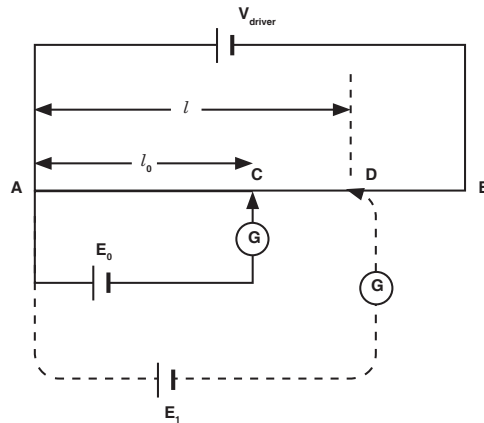

Fig. 6.18; Comparison of e.m.f.s

The balance point is first found with the standard cell of e.m.f E_0 at a balance length l_0 . A new balance length l is then found with the cell e.m.f. E_1 .

$$\therefore E_0 = V_{AC} \text{ and } E_1 = V_{AD}$$

Since $V_{AC} \propto l_0$ and $V_{AD} \propto l$;

$$\frac{V_{AC}}{V_{AD}} = \frac{l_0}{l} \Leftrightarrow \frac{E_0}{E_1} = \frac{l_0}{l} \text{ ..Equation 6.8}$$

So if the standard e.m.f. E_0 is known, lengths l_0 and l are known, then E_1 can be calculated.

EXAMPLE 6.6

In Fig.6.19, AB is a uniform wire of length 1.2 m and resistance 8Ω . A driver cell of e.m.f. 3V and internal resistance 1Ω is driving a current I_p as shown. Calculate the e.m.f. of the cell E_x if the balance length is 66.5 cm.

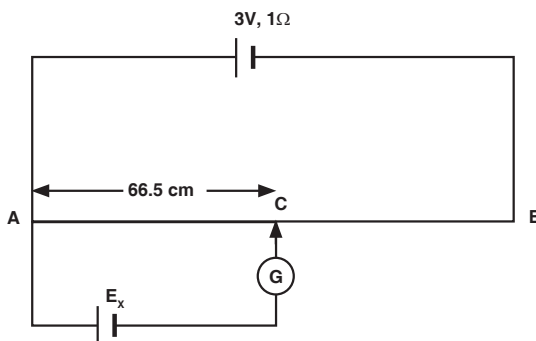

Fig. 6.19; Determination of unknown e.m.f. by comparison

Solution:

Data given:

$$l_{AC} = 66.5 \text{ cm},$$

$$l_{AB} = 120 \text{ cm},$$

$$R_{AB} = 8 \Omega,$$

$$V_{AB} = 3\text{V}$$

$$I_p = \frac{V_{AB}}{R_{AB}} = \frac{3}{8+1} = \frac{1}{3} \text{ A}$$

$$\frac{R_{AC}}{R_{AB}} = \frac{l_{AC}}{l_{AB}}$$

$$\frac{l_{AC} \times R_{AB}}{l_{AD}} = \frac{66.5 \times 8}{120} = 4.43 \Omega$$

$$V_{AC} = E_x = I_p R_{AC} = \frac{1}{3} \times 4.43 = 1.48 \text{ V}$$

6.4.2 Measurement of internal resistance of a cell

The circuit is arranged as shown in Fig. 6.20 with the cell, whose internal resistance r is to be found, is connected in parallel with a resistor with resistance R and a switch. The driver cell as usual is in the upper loop of the circuit.

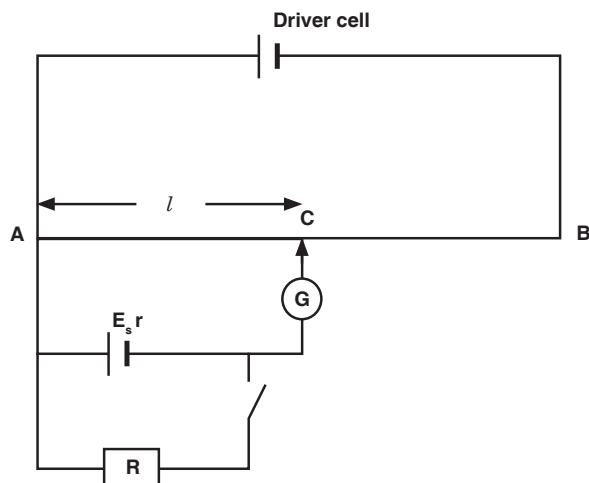

Fig.6.20; Measurement of internal resistance of a cell

The balance point l is found with the switch open. Since at balance point, no current is flowing through G ; E is then measured. The switch is then closed and the new balance point l_1 is found. Balance length l_1 is proportional to output voltage V (across the resistor R); *i.e.*

$$V \propto l_1$$

$$E \propto l$$

$$\therefore \frac{E}{V} = \frac{l}{l_1} \quad \dots \text{Equation 6.9}$$

But in the lower circuit;

$$E = V + Ir \quad \dots \text{Equation 6.10}$$

Substituting equation 5.10 into equation 5.9 gives;

$$\frac{V + Ir}{V} = \frac{l}{l_1}$$

But $V = IR$

$$\frac{IR + Ir}{IR} = \frac{l}{l_1}$$

$$r = R\left(\frac{l}{l_1} - 1\right)$$

\therefore

$$l = \frac{75}{2 \times 0.4} = 93.75 \text{ cm}$$

$$\dots \text{Equation 6.11}$$

EXAMPLE 6.7

In the circuit of Fig. 6.21 below, AB is a uniform wire of length 1m and resistance 4.0Ω . C_1 is an accumulator of e.m.f. 2 V a negligible internal resistance. C_2 is a cell of e.m.f. 1.5 V.

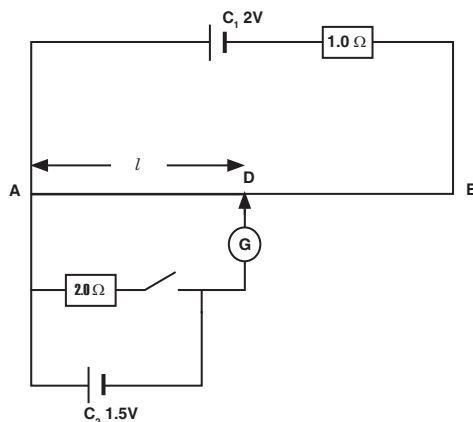

Fig.6.21; Determination of internal resistance using a potentiometer wire

- Find the balance length AD when the switch is open.
- If the balance length is 75.0 cm when the switch is closed, find the internal resistance of C_2 .

Solution:

- When the switch is open at balance D , no current flows in the lower part of the circuit.

$$V_{AD} = \frac{l \times V_{AB}}{l_{AB}} = 1.5$$

\therefore

$$l = \frac{1.5 \times 100}{V_{AB}} \Leftrightarrow l = \frac{150}{IR_{AB}}$$

$$l = \frac{150}{4I} = \frac{75}{2I}$$

In the upper loop;

$$E = I \times R_{\text{total}}$$

\therefore

$$2 = I(1 + R_{AB})$$

$$2 = I(1 + 4)$$

$$I = 0.4 \text{ A}$$

(b) When the switch is closed, the internal resistance of the cell can be calculated from equation 6.15.

$$\therefore r = R \left(\frac{l}{l_1} - 1 \right) = 2 \left(\frac{93.75}{75} - 1 \right) = 0.5 \Omega$$

6.5 MEASUREMENT OF CURRENT BY POTENTIOMETER

Consider the circuit of Fig. 6.22 shown below. Current through a resistor can be calculated at the balance point.

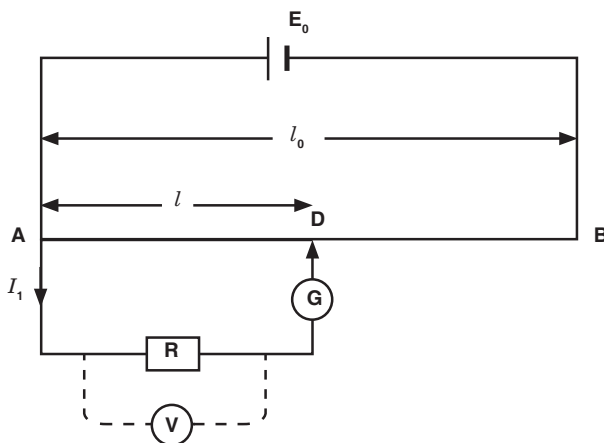

Fig. 6.22; Measurement of current by potentiometer

The potential difference, p.d. across R can be found by finding the balance point on the potentiometer such that if the balance point is at C then V_{AC} balances the p.d. across R . If R is known, then the current can be found.

$$V_{AC} \propto l$$

$$E_0 \propto l_0$$

$$\therefore \frac{V_{AC}}{E_0} = \frac{l}{l_0}$$

$$V_{AC} = I_1 R$$

$$\frac{I_1 R}{E_0} = \frac{l}{l_0}$$

$$\Rightarrow I_1 = \frac{l E_0}{l_0 R} \quad \dots \text{Equation 6.12}$$

ACTIVITY 6-4

To measure the e.m.f. of an unknown cell using a potentiometer.

Procedure:

- Connect the circuit as shown in Fig. 6.23. Voltage supply is set at its appropriate value, so the current is fairly small. This is to protect the galvanometer.
- Close the DPDT (Double Pole Double Throw) switch to the standard cell side and calibrate the potentiometer by finding what length of wire corresponds to the voltage of the standard cell. This is done by finding the location of the sliding contact where the galvanometer does not deflect when the key switch is closed.
- Calculate the constant, k , using the e.m.f. of the standard cell and the length, L_s measured to the sliding contact-use equation $E = kL_s$.
- Throw the DPDT switch to connect the unknown battery in the circuit and move the sliding contact until the galvanometer indicates zero current as in Step 2. (Do not adjust Rheostat R_t since this will change the voltage across the potentiometer wire and upset your calibration). Read the length L_v measured on the sliding contact.
- Calculate the e.m.f. of the unknown battery by the formula: $E = kL_v$
- Now measure the voltage of the unknown battery with the voltmeter. Explain the difference.

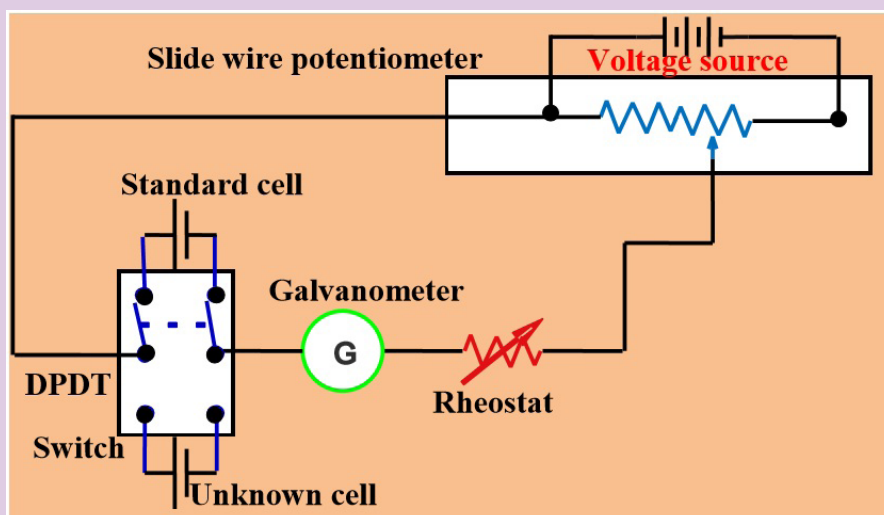

Fig.6.23; To measure the e.m.f. of an unknown cell using a potentiometer

ACTIVITY 6-5

Determination of the constant ϕ of the wire.

Procedure:

- (a) Fix the wire provided firmly on the bench.

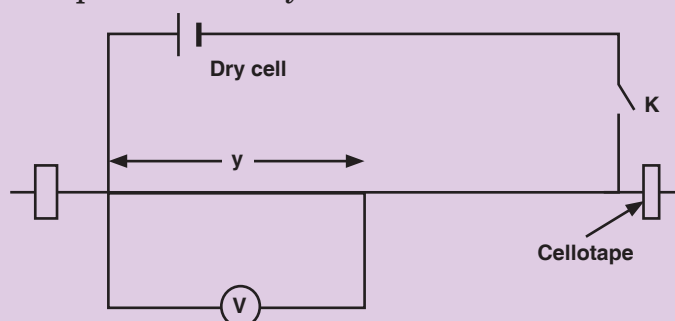

Fig. 6.24; Determination of the constant ϕ of the wire

- (b) Connect the circuit as shown on the figure above starting with a length of the wire, y , equal to 30 cm.
- (c) Close the switch K .
- (d) Read and record the reading V of the voltmeter.
- (e) Open the switch K .
- (f) Repeat procedures (c) to (e) for the values of $y = 40, 50, 60$ and 70 cm.
- (g) Record your results in a suitable table including the values of $\frac{1}{V}$ and $\frac{1}{y}$.
- (h) Plot a graph of $\frac{1}{V}$ (along the vertical axis) against $\frac{1}{y}$ (along the horizontal axis).
- (i) Find the slope s of the graph.
- (j) Determine the intercept c on $\frac{1}{V}$ axis.
- (k) Calculate the constant of the wire from the expression $\phi = \frac{100c}{s}$.

Application Activity 6.1

1. A potentiometer is set up as shown in Fig. 6.25. Given that the balancing point for the unknown e.m.f. E is found to be 74.5 cm from the left hand end of the meter wire (1 m). If the driver cell has an e.m.f. of 1.5 V and negligible internal resistance. Find the value unknown e.m.f.

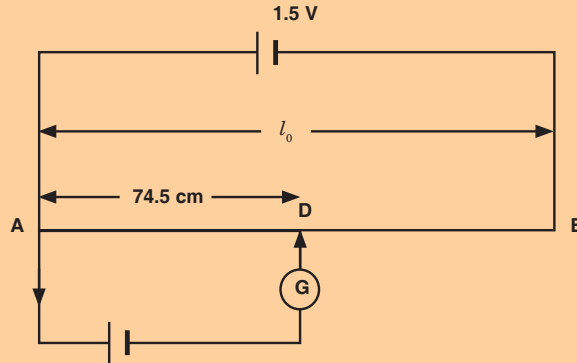

Fig. 6.25; Calculating unknown e.m.f.

2. A certain cell is connected to a potentiometer and a balance point is obtained at 84 cm along the meter wire. When its terminals are connected to a $5\ \Omega$ resistor, the balance point changes to 70 cm. Calculate the balance when a $5\ \Omega$ resistor is now replaced by a $4\ \Omega$ resistor.

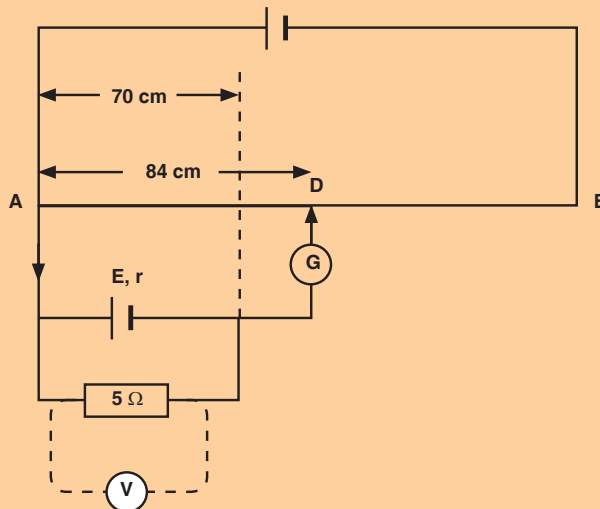

Fig. 6.26; Calculation of the balance length

6.6 ADVANTAGES AND DISADVANTAGES OF POTENTIOMETER

Wear: Most potentiometers last only a few thousand rotations before the materials wear out. Although it means years of service in some applications, it takes special designs to stand up to daily, demanding use. It means they can't be used for machine sensing where rapid cycling would wear them out in a matter of minutes.

Noise: The action of the wiper moving across the element creates a noise called "fader scratch." In new pots, this noise is inaudible, but it can get worse with age. Dust and wear increase the bumpiness of the action and make the noise noticeable. Small cracks can appear in the element, and these make noise as the wiper moves over them.

In addition to these mechanically caused noises, carbon elements, in particular, are prone to producing electrical noise. This noise is heard as a soft, steady hiss that can degrade sound recordings. The resistive materials have improved over the years, so newer pots are quieter.

Inertia: The friction between the potentiometer's wiper and resistive element creates a drag or inertia that the pot must overcome before it turns. Although this drag is not large, it prevents the pot from being used as a rotary sensor in more sensitive applications.

Limited Power: Out of necessity, most potentiometers can dissipate only a few watts of power. To handle more power, they have to be larger and hence expensive. Engineers work around this problem by putting the potentiometer in low-power parts of circuits. They control small currents, which, in turn, control transistors and other components with greater power ratings.

END OF UNIT ASSESSMENT

1. What are Kirchhoff's rules for understanding a circuit?
2. Explain why Kirchhoff's junction rule must be true if the Law of Conservation of Charge (that no charge may be created or destroyed) is true.
3. Explain why Kirchhoff's loop rule must be true if the Law of Conservation of Energy is true.
4. Find the branch currents of the circuit shown below.

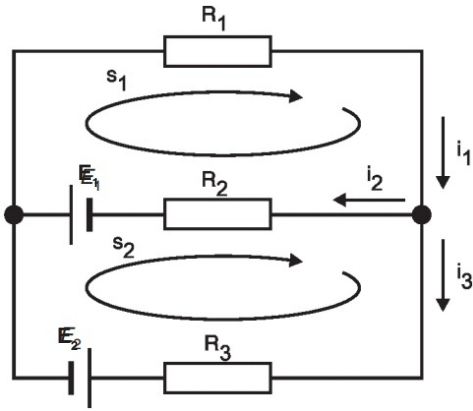

Fig.6.27; Calculation of branch currents 1

5. Solve the circuit for currents I_1 , I_2 , and I_3 , using Kirchhoff's rules.

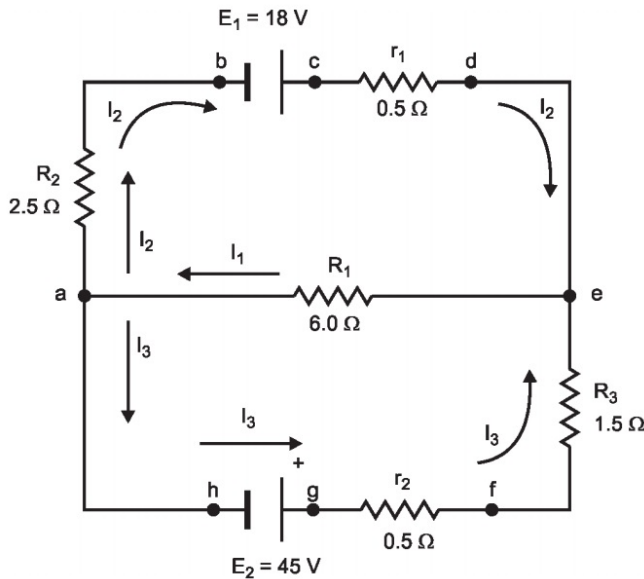

Fig.6.26; Calculation of branch currents 2

6. Find the current flowing in the resistor R_3 of 40Ω .

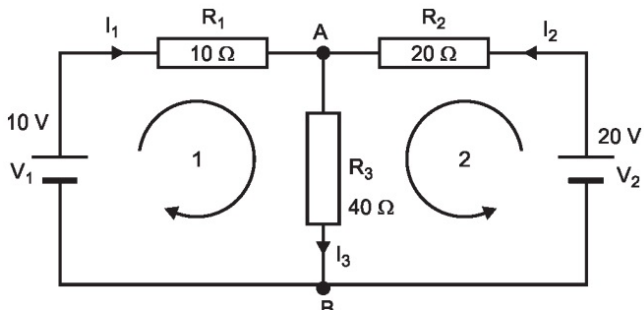

Fig.6.27; Calculation of branch currents 3

7. Find the value of current in resistance R_3 as shown in figure 6.28 below, where $R_1 = 1 \Omega$, $R_2 = 2 \Omega$, $R_4 = 3 \Omega$, $R_5 = 6 \Omega$, $R_3 = 2 \Omega$ and $E_1 = 10 \text{ V}$.

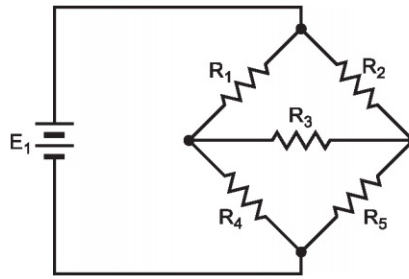

Fig. 6.23; Applying Kirchoff's laws on the bridge of resistors

8. Apply Kirchoff's loop rule to as many closed loops of the circuit as are necessary and calculate the loop currents.

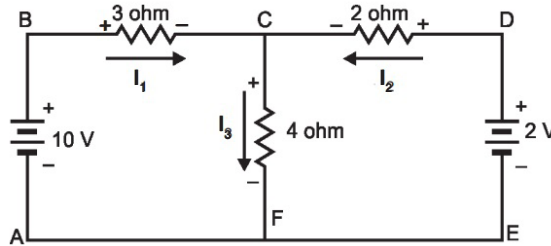

Fig. 6.24; Calculation of branch currents

9. Find the current in each resistor, the equivalent resistance of the network of five resistors and the potential difference V_{ab}

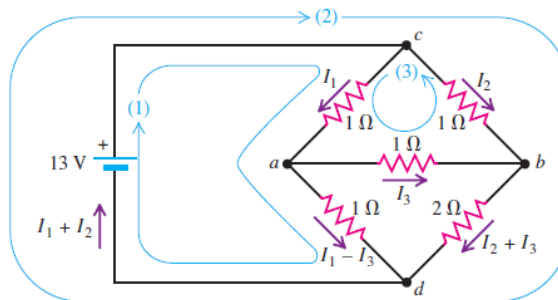

Fig. 6.25

10. Find the current i_0 in the circuit in Fig. below using loop analysis

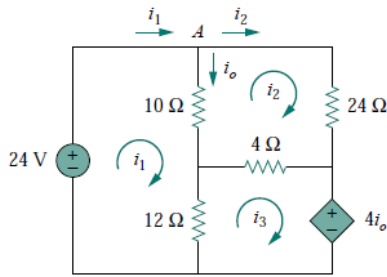

Fig. 6.26

11. For the circuit in Fig. below, find the branch currents I_1 , I_2 , and I_3 using loop analysis.

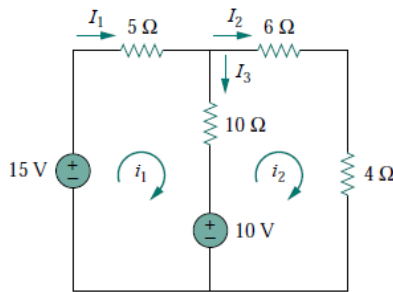

Fig. 6.27

12. (a) For the circuit shown in Fig. below find the reading of the idealized ammeter if the battery has an internal resistance of 3.26Ω

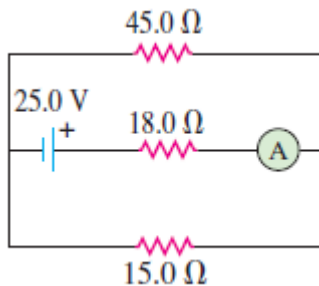

Fig. 6.28

- (b) Solve the equations to find the current through each resistor in the circuit.
13. (a) Apply Kirchhoff's rules to the following circuit to find a set of equations that describe how charges behave inside the circuit.

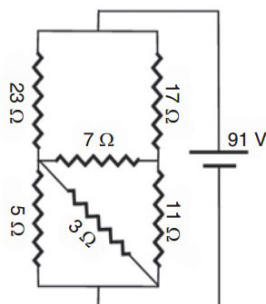

Fig.6.29

- (b) Solve the equations to find the current through each resistor in the circuit.

UNIT SUMMARY

Kirchhoff's laws

There are two Kirchhoff's laws: Kirchhoff's Current Law states that “*the algebraic sum of the currents flowing at a node or junction in an electric circuit is zero.*”

Kirchhoff's Voltage Law states that “*the algebraic sum of the potentials around a closed electric circuit is zero.*”

To solve the resistor circuits using Kirchhoff's rules

1. Define the various currents
 - Can either define branch (segment) currents for each element in the circuit
 - Or can define loop currents for each loop in the circuit
2. If using branch currents, use Kirchhoff's Junction Rule to look for interdependent currents. This allows for reducing the number of variables being solved for.
3. Use Loop Rule to define voltage equations for each loop, using previously defined currents.
4. Solve set of simultaneous equations using algebraic manipulation.

A simple potentiometer is a device used for taking a number of electrical measurements. It is a piece of resistance wire, usually a metre long, fixed between two points *A* and *B* with a cell of output voltage, *V*, connected between the two ends.

Potentiometer can be used to

- (i) compare e.m.f.'s of two primary cells.
- (ii) measure internal resistance of a cell.

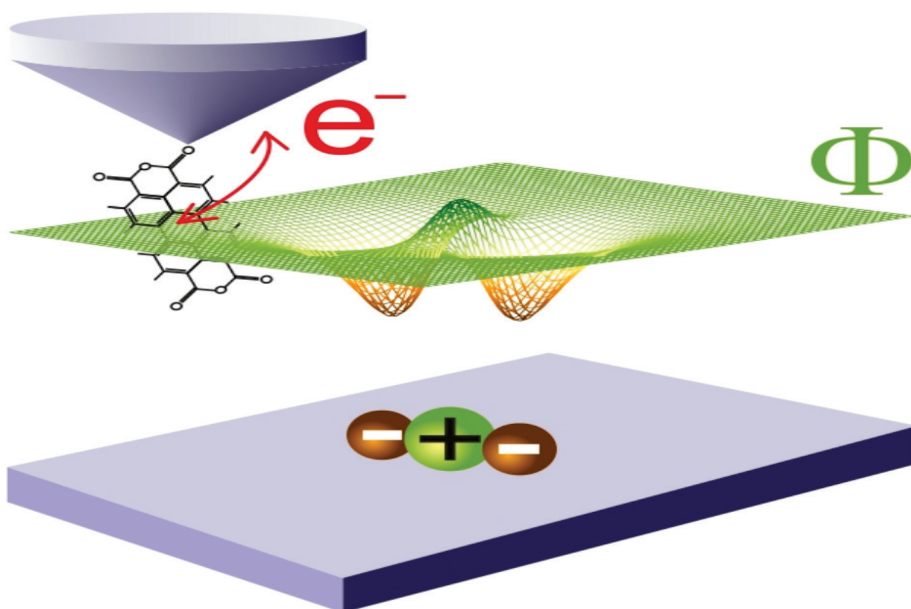
UNIT
7**ELECTRIC FIELD AND
GRAVITATIONAL POTENTIAL**

Key unit competence: Analyze electric field potential and gravitational potential.

Unit Objectives:

By the end of this unit, I will be able to;

- ◇ list the properties of an electric and gravitational fields and the variation of potentials properly.
- ◇ explain the working mechanism of a cathode ray tube, TV tubes and computer monitors properly.
- ◇ explain the everyday applications of electric and magnetic fields.

7.0 INTRODUCTION

Electricity might be leading technological advancement, but its study began with nature. Electrical storms are a very dramatic example of natural phenomena involving electricity. Other examples are found in animals. Some use electricity as a tool for survival – as a weapon (by electric eels) or to sense live food (by platypus and sharks). Animals routinely use electricity to control their bodies. The story of Frankenstein’s monster, brought to life during an electrical storm, was inspired by early experiments where the legs of a dead frog were made to twitch by sending electrical current through them. Today we use electrical technology not just to support our everyday lives in a myriad of ways, but also to diagnose muscle and nerve activity inside the body, and to assist faulty signaling in the body.

7.1 ELECTRIC POTENTIAL

7.1.1 Electric field and Coulomb’s law

When a small charged particle is located in the area surrounding a charged object, the charged particle experiences a force in accordance with Coulomb’s Law. The space around the charged object where force is exerted on the charged particle is called an **electric field** or **electrostatic field**. Theoretically, an electric field due to charge extends to infinity but its effect practically dies away very quickly as the distance from the charge increases.

Electric field is a vector quantity whose direction is defined as the direction which a positive test charge would be pushed when placed in the field. Thus, the electric field direction about a positive charge is always directed away from the positive source. And the electric field direction about a negative charge is always directed toward the negative source as shown in Fig.7.1

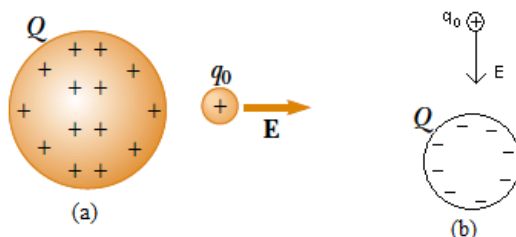

Fig.7.1 A small positive test charge q_0 placed near an object carrying a much larger positive charge Q experiences an electric field E directed as shown

Electric field exists at a point if a test charge at that point experiences an electric force.

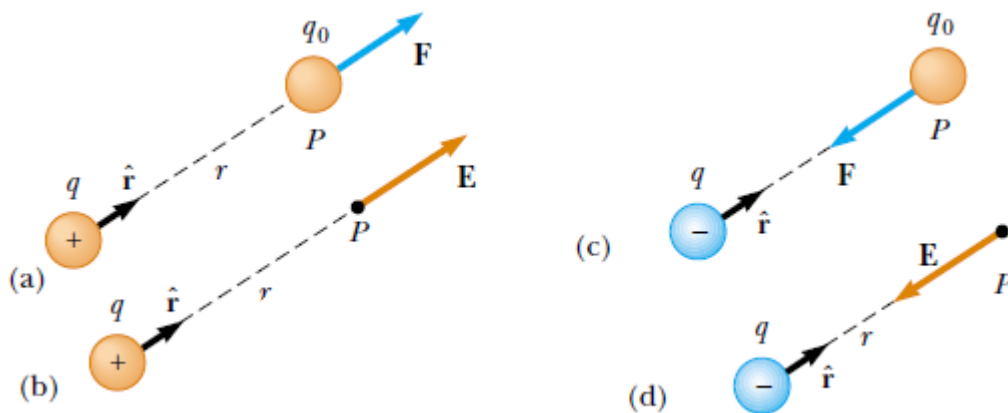

Fig.7.2 A test charge q_0 at point P is a distance r from a point charge q . (a) If q is positive, then the force on the test charge is directed away from q . (b) For the positive source charge, the electric field at P points radially outward from q . (c) If q is negative, then the force on the test charge is directed toward q . (d) For the negative source charge, the electric field at P points radially inward toward q .

The magnitude of the field is proportional to the number of field-lines per unit area passing through a small surface normal to the lines.

The electric field strength or *The electric field E at a point in space is defined as the electric force F_e acting on a positive test charge q_0 placed at that point divided by the magnitude of the test charge:*

The electric field strength or The electric field E at a point in space is defined as the electric force F_e acting on a positive test charge q_0 placed at that point divided by the magnitude of the test charge:

$$E = \frac{F_e}{q_0} \quad \text{.....Equation 7-1}$$

We require the *test charge* to be *small enough* to have a *negligible effect on the charges on the sphere*. A large test charge will cause a rearrangement of the charges of the sphere due to induction and thus the test charge does not have negligible effect on the sphere.

According to Coulomb's law, the force exerted by q on the test charge is

$$F_e = \frac{kq_0q}{r^2} \quad \text{.....Equation 7-2}$$

We find that at P , the electric field created by q_o is

$$E = \frac{kq_o}{r^2} \quad \text{.....Equation 7-3}$$

The value of the Coulomb constant in Equations 7.02 and 7.03 depends on the choice of units

$$k = 8.9875 \times 10^9 \text{ N}\cdot\text{m}^2 / \text{C}^2$$

This number can be rounded, depending on the accuracy of other quantities in a given problem. We'll use either two ($k = 9.0 \times 10^9 \text{ N}\cdot\text{m}^2 / \text{C}^2$) or three significant digits $k = 8.99 \times 10^9 \text{ N}\cdot\text{m}^2 / \text{C}^2$.

Compare Eq. (7.1) to the familiar expression for the gravitational force F_G that the earth exerts on a mass m_o , we get

$$E = \frac{F_G}{m_o} \quad \text{.....Equation 7-4}$$

Thus gravitational field g can be regarded as the gravitational force per unit mass or the acceleration due to gravity. The gravitational field or gravitational force per unit mass, is a useful concept because it does not depend on the mass of the body on which the gravitational force is exerted; likewise, the electric field or electric force per unit charge, is useful because it does not depend on the charge of the body on which the electric force is exerted

Example 7.1 Electric field due a single point charge

1. Calculate the magnitude and direction of the electric field at a point P which is 30 cm to the right of a point charge $q_o = -3.0 \times 10^{-6} \text{ C}$.

Answer

The magnitude of the electric field due to a single point charge is given by

$$E = \frac{kq_o}{r^2} = \frac{(9.0 \times 10^9 \text{ N}\cdot\text{m}^2 / \text{C}^2)(-3.0 \times 10^{-6} \text{ C})}{(30 \times 10^{-2} \text{ m})^2} = -3.0 \times 10^5 \text{ N / C}$$

The direction of the electric field is toward the charge q as shown in Fig. 7.3a, since we defined the direction as that of the force on a positive test charge which here would be attractive.

If q had been positive, the electric field would have pointed away, as in Fig. 7.3b.

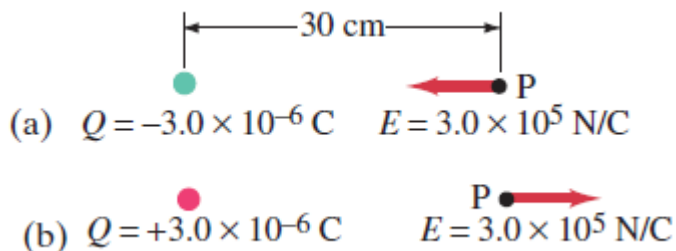

Fig. 7.3 Electric field due to a single point charge

NOTE There is no electric charge at point P. But there is an electric field there. The only real charge is q

7.1.2 Electric potential and electric potential energy

Electric potential is the potential energy per charge.

$$V = \frac{U}{q_o} \quad \text{.....Equation 7-5}$$

The SI unit of electric potential is J/C or V named in honor of **Alessandra Volta**

The amount of work W done by the electric field E created by q to move the test charge q_o a distance d is given by

$$W_{ab} = Fd = q_oEd \quad \text{.....Equation 7-6}$$

It follows that when the particle moves from a point where its potential energy is U_a to a point where it is U_b , the change in electric potential energy is given by

$$\Delta U_{ba} = -W_{ab} = -q_oEd \quad \text{.....Equation 7-7}$$

The change in potential energy between any two points, a and b, equals the negative of the work done by the conservative force on an object as it moves from point a to point b.

If we solve (7.01) and (7.03) for E , we find the general expression for potential difference at a point located a distance d from the charge

$$V_{ba}q_o = -q_oEd \Leftrightarrow V_{ba} = -Ed \quad \text{.....Equation 7-8}$$

This equation is Potential difference.

Example 7.2: Motion of a Proton in a Uniform Electric Field is only valid for the case of a uniform electric field

1. A proton is released from rest in a uniform electric field that has a magnitude of $8.0 \times 10^4 \text{ V/m}$ and is directed along the positive x axis (Fig. 7.1). The proton undergoes a displacement of 0.50 m in the direction of E .

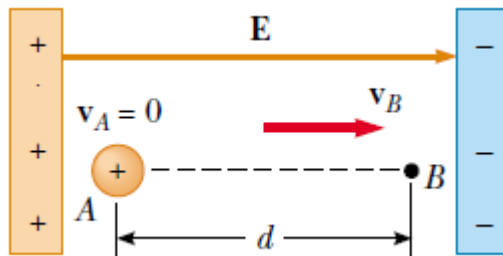

Fig.7.4 A proton accelerates from A to B in the direction of the electric field.

- Find the change in electric potential between points A and B.
- Find the change in potential energy of the proton for this displacement.
- Use the concept of conservation of energy to find the speed of the proton at point B (after completing the 0.50 m displacement in the electric field)
- What if the situation is exactly the same as that shown in Figure, but no proton is present? Could both parts (A) and (B) of this example still be answered?

Answer

(a) the change in Electric potential

$$V_{ba} = -Ed = -(8.0 \times 10^4 \text{ V/m})(0.50 \text{ m}) = -4.0 \times 10^4 \text{ V}$$

(b) the change in potential energy

$$U_{ba} = V_{ba}q = (-4.0 \times 10^4 \text{ V/m})(1.6 \times 10^{-19} \text{ C}) = -6.4 \times 10^{-15} \text{ J}$$

The negative sign means the potential energy of the proton decreases as it

moves in the direction of the electric field; it gains kinetic energy and at the same time loses electric potential energy.

(c) The charge–field system is isolated, so the mechanical energy of the system is conserved:

$$\Delta K + \Delta U = 0 \Leftrightarrow v = \sqrt{\frac{-2\Delta U}{m}} = \sqrt{\frac{-2(-6.4 \times 10^{-15} \text{ J})}{1.67 \times 10^{-27} \text{ kg}}} = 2.8 \times 10^6 \text{ m/s}$$

(d) Part (A) of the example would remain exactly the same because the potential difference between points A and B is established by the source charges in the parallel plates. The potential difference does not depend on the presence q_o of the proton, which plays the role of a test charge.

Part (B) of the example would be meaningless if the proton is not present. A change in potential energy is related to a change in the charge–field system. In the absence of the proton, the system of the electric field alone does not change

❖ **Positive charge moving in opposite direction of electric field**

Now let us calculate the potential difference between two points A and B in the field of a single positive charge q , see the Fig.7.5.

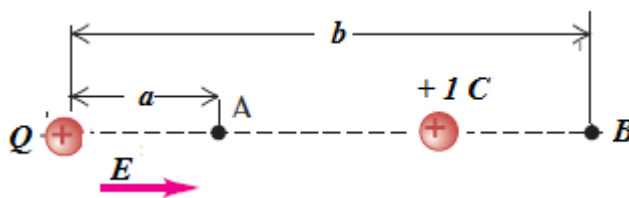

Fig.7.5 Test charge moves along a straight line extending radially from charge q .

When a unit test charge q_o is placed in electric field E created by some source charge distribution at a distance r_o from the charge q placed at 0 in free space the electric force acting on the test charge is given by

$$F = q_o E = \frac{qq_o}{4\pi\epsilon_0 r^2} \dots\dots\dots \text{Equation 7-9}$$

This force is conservative because the force between charges described by Coulomb’s law is conservative. When the test charge is moved in the field by some external agent, the work done by the field on the charge is equal to the negative of the work done by the external agent causing the displacement.

The force is *not* constant during the displacement, the work done in taking the charge from B to A, against the electric field E over short distance dr is

$$dW_{ex} = d(-W_F) = -q_0 E dr = -\frac{qq_0}{4\pi\epsilon_0 r^2} dr \quad \dots\dots\dots\text{Equation 7-10}$$

Over the whole distance BA, therefore, the work done by the force on the unit charge is given by:

$$W_{ba} = -\int_b^a \frac{qq_0}{4\pi\epsilon_0 r^2} dr = -\frac{qq_0}{4\pi\epsilon_0} \int_b^a \frac{dr}{r^2} = -\frac{qq_0}{4\pi\epsilon_0} \left| -\frac{1}{r} \right|_b^a = \frac{qq_0}{4\pi\epsilon_0} \left(\frac{1}{a} - \frac{1}{b} \right) \quad \dots\dots\dots\text{Equation 7-11}$$

Work done by an external agent to carry a unit charge from the charge q placed at point B to point A in free space will be equal to the potential difference V_{ab} between A and B and is given by:

$$V_{ab} = V_a - V_b = \frac{W_{ba}}{q_0} = -\frac{q}{4\pi\epsilon_0} \left(\frac{1}{a} - \frac{1}{b} \right) \quad \dots\dots\dots\text{Equation 7-12}$$

If B is at infinity, then since B is very much greater than A, $\frac{1}{b}$ is negligible compared with $\frac{1}{a}$.

So the electric potential at a is $V_a = \frac{q}{4\pi\epsilon_0 a} \quad \dots\dots\dots\text{Equation 7-13}$

Thus the **electric potential at an arbitrary point** in an electric field equals the work required per unit charge to bring a positive test charge from infinity to that point

The potential near a positive charge is large and positive, and it decreases toward zero at very large distances, Fig.7.6a. The potential near a negative charge is negative and increases toward zero at large distances, Fig.7.6b.

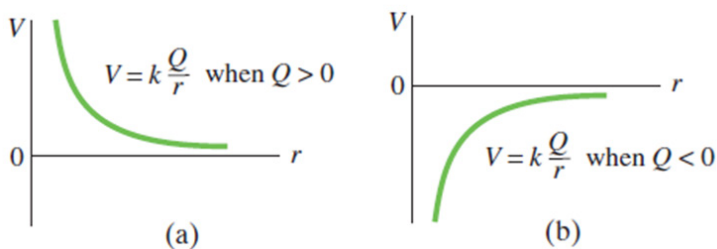

Fig.7. 6 Potential V as function of distance r from a single point charge Q when the charge is (a) positive, (b) negative.

Example 7.3: Work required to bring two positive charges close

1. Two positive point charges, of $12 \mu\text{C}$ and $8 \mu\text{C}$ respectively, are 10 cm apart.

(a) Find the work done in bringing them 4 cm closer so they are 6 cm apart.

$$\text{(Assume } k = \frac{1}{4\pi\epsilon_0} = 9.0 \times 10^9 \text{ m / F).}$$

(b) What minimum work must be done by an external force to bring a charge $12 \mu\text{C}$ from a great distance away (take $r = \infty$) to a point 0.500 m from a charge $8 \mu\text{C}$

(c) What work is required to bring a charge $12 \mu\text{C}$ originally a distance of 1.50 m from a charge $Q = 20.0 \text{ mC}$ until it is 0.50 m away?

Answer

(a) Suppose the $12 \mu\text{C}$ charge is fixed in position, then the potential difference between points 6 cm and 10 cm from it is given by:

$$V = \frac{12 \times 10^{-6}}{4\pi\epsilon_0} \left(\frac{1}{0.06} - \frac{1}{0.1} \right) = 72\,000 \text{ V}$$

The work done in moving the $8 \mu\text{C}$ charge from 10 cm to 6 cm away from the $12 \mu\text{C}$ charge is given by using: $W = qV = (8 \times 10^{-9} \text{ V})(72\,000 \text{ V}) = 5.8 \text{ J}$

(b) The external work required is equal to the change in potential energy:

$$W_{\text{ext}} = q(V_b - V_a) = kqq_0 \left(\frac{1}{r_b} - \frac{1}{r_a} \right) = 9.0 \times 10^9 \times 12.0 \times 10^{-6} \times 8 \times 10^{-6} \left(\frac{1}{0.500} - 0 \right) = 1.728 \text{ J}$$

(c) The external work required is equal to the change in potential energy:

$$W_{\text{ext}} = \Delta U$$

$$W_{\text{ext}} = kqq_0 \left(\frac{1}{r_b} - \frac{1}{r_a} \right) = (9.0 \times 10^9)(12.0 \times 10^{-9})(20 \times 10^{-3}) \left(\frac{1}{0.500} - \frac{1}{1.50} \right) = -1\,438 \text{ J}$$

7.1.3 Equipotential Lines and Surfaces

The electric potential can be represented by drawing **equipotential lines** or **equipotential surfaces**. An equipotential surface is the one on which all points are at the same potential. The potential difference between any two points on the surface is zero, so no work is required to move a charge from one point on the surface to the other. An **equipotential surface must be perpendicular to the electric field** at any point. If this was not so—that is, if there was a component of \vec{E} parallel to the surface—it would require work to move the charge along the surface against this component of \vec{E} ; and this would contradict the idea that it is an *equipotential* surface. The fact that the electric field lines and equipotential surfaces are mutually perpendicular, helps us locate the equipotentials when the electric field lines are known. In a normal two-dimensional drawing, we show equipotential **lines**, which are the intersections of equipotential surfaces with the plane of the electric field line.

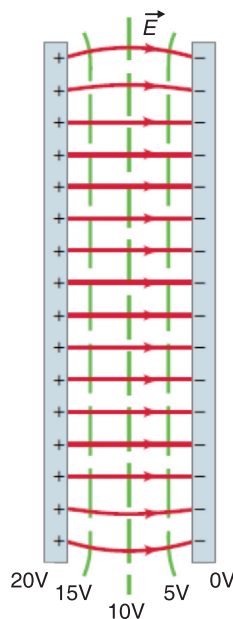

Fig. 7.7. Equipotential lines between two charged parallel plates are always perpendicular to the electric field.

In Fig. 7.7, a few of the equipotential lines are drawn (dashed green lines) for the electric field (red lines) between two parallel plates maintained at a potential difference of 20 V. The negative plate is arbitrarily chosen to be zero volts and the potential of each equipotential line is indicated.

Note that \vec{E} points towards lower values of V .

7.1.4 Potential due to electric dipole

The field lines between two opposite and equal charges make what is called a **dipole**. An electric dipole is a pair of point charges with equal magnitude and opposite sign (a positive charge $+q$ and a negative charge $-q$) separated by a distance a .

The equipotential lines for the case of two equal but oppositely charged particles are shown in Fig. 7.8 as green dashed lines.

Unlike electric field lines, which start and end on electric charges, equipotential lines and surfaces are always continuous curves, and continue beyond the borders indicated in Figs. 7.7 and 7.8.

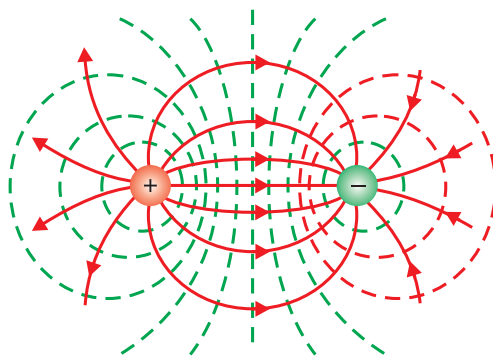

Fig. 7.8. Two equal but oppositely charged particles (an “electric dipole”).

Electric Potential Energy with Several Point Charges

We obtain the electric potential resulting from two or more point charges by applying the **superposition principle**. That is, the total electric potential at some point P due to several point charges is the sum of the potentials due to the individual charges. For a group of point charges, we can write the total electric potential at P in the form:

$$V = \sum_{i=0} \frac{q_i}{4\pi\epsilon_0 r_i} \quad \text{.....Equation 7-14}$$

If the system consists of more than two charged particles, we can obtain the total potential energy by calculating U for every pair of charges and summing the terms algebraically. As an example, the total potential energy of the system of three charges shown in Fig. 7. 10 is

$$U = k\left(\frac{q_1q_2}{r_{12}} + \frac{q_2q_3}{r_{23}} + \frac{q_1q_3}{r_{13}}\right) \quad \text{.....Equation 7-15}$$

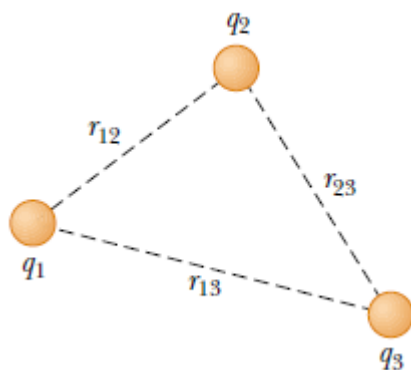

Fig.7. 9 Three point charges are fixed at the positions shown.
The potential energy of this system of charges is given by Equation 7.15.

Example 7.4: The Electric Potential Due to Two Point Charges

1. A charge $q_1 = 2.00 \mu\text{C}$ is located at the origin, and a charge $q_2 = -6.00 \mu\text{C}$ is located at $(0, 3.00) \text{ m}$, as shown in Fig.7.10 below
 - (a) Find the total electric potential due to these charges at the point P , whose coordinates are $(4.00, 0) \text{ m}$.
 - (b) Find the change in potential energy of a $q_3 = 3.00 \mu\text{C}$ charge as it moves from infinity to point P
 - (c) Find the total potential energy of the system.

Answer

a. The electric potential at P due to the two charges is the sum of the potentials due to the individual charges.

$$V = k\left(\frac{q_1}{r_1} + \frac{q_2}{r_2}\right) = (8.988 \times 10^9 \text{ C}^2/\text{N}\cdot\text{m}^2)\left(\frac{2.0 \times 10^{-6} \text{ C}}{4.00 \text{ m}} + \frac{-6.0 \times 10^{-6} \text{ C}}{5.00 \text{ m}}\right) = -6.29 \times 10^3 \text{ V}$$

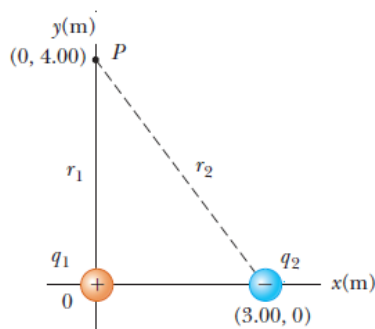

Fig.7. 10 The electric potential at point P due to the point charges q_1 and q_2 is the algebraic sum of the potentials due to the individual charges.

b. When the charge is at infinity, $\Delta U_i = 0$, and when the charge is at P ,
 $U_f = q_3 V_p$;

Therefore, $\Delta U = (V_p - V_\infty)q_3 = (-6.29 \times 10^3 V - 0)(3.00 \times 10^{-6} C) = -18.9 \times 10^{-3} J$

Therefore, because the potential energy of the system has decreased, positive work would have to be done by an external agent to remove the charge from point P back to infinity.

c. The total potential energy of the system

$$U = k\left(\frac{q_1 q_2}{r_{12}} + \frac{q_2 q_3}{r_{23}} + \frac{q_1 q_3}{r_{13}}\right) = -5.48 \times 10^{-3} J$$

Example 7.5: Electric Potential and energy due to electric dipole

1. An electric dipole consists of point charges $q_1 = 12 \text{ nC}$ and $q_2 = -12 \text{ nC}$ placed 10.0 cm apart (Fig.7.10).

Compute

- The electric potentials at points a, b and c.
- The potential energy associated with a $q = 4 \text{ nC}$ point charge if it is placed at points a, b and c.

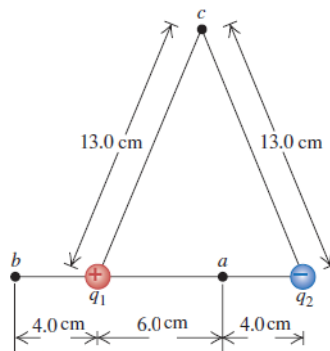

Fig.7.10 What are the potentials at points a, b, and c due to this electric dipole?

Answer

a) At point a we have $r_1 = 0.060 \text{ m}$ and $r_2 = 0.040 \text{ m}$ so Equ.7.32

$$V_a = k\left(\frac{q_1}{r_1} + \frac{q_2}{r_2}\right) = (9.0 \times 10^9 \text{ N} \cdot \text{m}^2 / \text{C}^2)\left(\frac{12 \times 10^{-9} \text{ C}}{0.060 \text{ m}} + \frac{-12 \times 10^{-9} \text{ C}}{0.040 \text{ m}}\right) = -900 \text{ V}$$

The electric potential at point *b* (where $r_1 = 0.040\text{ m}$ and $r_2 = 0.140\text{ m}$) is

$$V_b = k \sum_i^n \frac{q_i}{r_i} = (9.0 \times 10^9 \text{ N} \cdot \text{m}^2 / \text{C}^2) \left(\frac{12 \times 10^{-9} \text{ C}}{0.040 \text{ m}} - \frac{12 \times 10^{-9} \text{ C}}{0.140 \text{ m}} \right) = 1930 \text{ V}$$

The electric potential at point *c* (where $r_1 = r_2 = 0.130\text{ m}$) is

$$V_c = k \left(\frac{q_1}{r_1} + \frac{q_2}{r_2} \right) = (9.0 \times 10^9 \text{ N} \cdot \text{m}^2 / \text{C}^2) \left(\frac{12 \times 10^{-9} \text{ C}}{0.130 \text{ m}} - \frac{12 \times 10^{-9} \text{ C}}{0.130 \text{ m}} \right) = 0$$

b) at the three points we find

$$U_a = qV_a = (4.0 \times 10^9 \text{ C})(-900 \text{ J} / \text{C}) = -3.6 \times 10^{-6} \text{ J}$$

$$U_b = qV_b = (4.0 \times 10^9 \text{ C})(1930 \text{ J} / \text{C}) = 7.7 \times 10^{-6} \text{ J}$$

$$U_c = qV_c = 0$$

All of these values correspond to *U* and *V* being zero at infinity

7.1.5 Conservation of electrical energy

Energy is conserved in the movement of a charged particle through an electric field, as it is in every other physical situation. Electric charge cannot be created or destroyed (though positive and negative charges can neutralise each other).

Given a stationary test charge at a certain location, an applied electric field will cause the charge to move to one end or the other, depending on the charge.

Positive test charges will move in the direction of the field; negative charges will move in the opposite direction.

At the instant at which the field is applied, the motionless test charge has zero kinetic energy, and its electric potential energy is at the maximum. Now the charge accelerates, and its kinetic energy (due to motion) increases as its potential energy decreases. The sum of energies is always constant.

The formula illustrating conservation of energy can be written in many ways, but all expressions are based on the simple premise of equating the initial and final sums of kinetic (E_{kin}) and potential (E_{pot}) energy.

$$\begin{aligned} (E_{kin} + E_{pot})_{initial} &= (E_{kin} + E_{pot})_{final} && \text{..... Equation 7-16} \\ \{(E_{pot})_{initial} - (E_{pot})_{final}\} + \{(E_{kin})_{final} - (E_{kin})_{initial}\} &= 0 \end{aligned}$$

This equation can be written as:

$$\Delta E_{pot} + \Delta E_{kin} = 0$$

For small changes:

$$dE_{pot} + dE_{kin} = 0$$

This means that:

$$E_{pot} + E_{kin} = \text{constant} \quad \text{..... Equation 7-17}$$

Application Activity 7.1

1. Determine the potential at a point 0.50 m (a) from a $20 \mu\text{C}$ point charge, (b) from a $-20 \mu\text{C}$ point charge.
2. A particle of charge $q_1 = 6.0 \mu\text{C}$ is located on the x-axis at the point $x_1 = 5.1 \text{ cm}$. A second particle of charge $q_2 = -5.0 \mu\text{C}$ is placed on the x-axis at $x_2 = -3.4 \text{ cm}$.
 - a) What is the absolute electric potential at the origin ($x = 0$)?
 - b) How much work must we perform in order to slowly move a charge of $q_3 = -7.0 \mu\text{C}$ from infinity to the origin, while keeping the other two charges fixed?
3. Given two $2.00 \mu\text{C}$ charges, as shown in Figure below and a positive test charge $q = 1.28 \times 10^{-18} \text{ C}$ at the origin,
 - c) What is the net force exerted on q by the two $2.00 \mu\text{C}$ charges?
 - d) What is the electric field at the origin due to the two $2.00 \mu\text{C}$ charges?
 - e) What is the electric potential at the origin due to the two $2.00 \mu\text{C}$ charges?

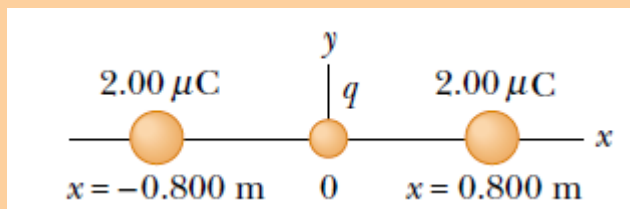

Fig.7. 12

7.2 ELECTRODYNAMICS

This is the study of phenomena associated with charged bodies in motion and varying electric and magnetic fields. Since a moving charge produces a magnetic field, electrodynamics is concerned with effects such as magnetism, electromagnetic radiation and electromagnetic induction, including some practical applications as the electric generator and the electric motor.

This area of electrodynamics, often known as classical electrodynamics, was first systematically explained by the physicist James Clarke Maxwell. Maxwell's equations, a set of differential equations, describe the phenomena of this area with great generality. A more recent development is quantum electrodynamics, which was formulated to explain the interaction of electromagnetic radiation with matter, to which the laws of the quantum theory apply.

When the velocities of the charged particles under consideration become comparable with the speed of light, corrections involving the theory of relativity must be made; this branch of the theory is called relativistic electrodynamics. It is applied to phenomena involved with particle accelerators and with electron tubes that are subject to high voltages and carry heavy currents.

7.2.1 Cathode ray tube

The CRT is a vacuum tube in which a beam of electrons is accelerated and deflected under the influence of electric or magnetic fields. The electron beam is produced by an assembly called an **electron gun** located in the neck of the tube. These electrons, if left undisturbed, travel in a straight-line path until they strike the front of the CRT, the “screen”, which is coated with a material that emits visible light when bombarded with electrons.

The operation of a CRT depends on **thermionic emission**, discovered by Thomas Edison (1847–1931). Consider a voltage applied to two small electrodes inside an evacuated glass “tube” as shown in Fig. 7.7: the **cathode** is negative, and the **anode** is positive. If the cathode is heated (usually by an electric current) so that it becomes hot and glowing, it is found that negative charges leave the cathode and flow to the positive anode. These negative charges are now called electrons, but originally they were called **cathode rays** because they seemed to come from the cathode.

Fig.7.13 is a simplified sketch of a CRT which is contained in an evacuated glass tube. A beam of electrons, emitted by the heated cathode, is accelerated by the high-voltage anode and passes through a small hole in that anode. The inside of the tube face on the right (the screen) is coated with a fluorescent

material that glows at the spot where the electron hits. Voltage applied across the horizontal and vertical deflection plates can be varied to deflect the electron beam to different spots on the screen. The instruments used in the laboratory to display, measure and analyse the waveforms of different circuits is known as **cathode ray oscilloscope**.

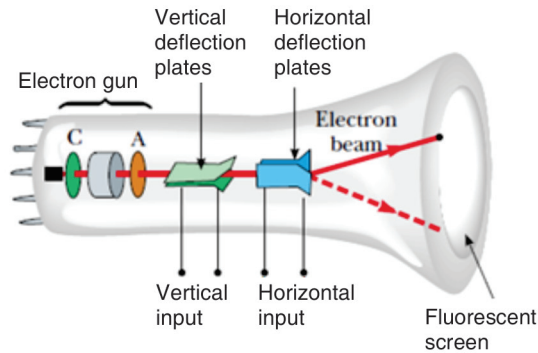

Fig. 7-13: Cathode ray oscilloscope

7.2.2 TV and computer monitors

In TV and computer monitors, the CRT electron beam sweeps over the screen in the manner shown in Fig.7.14 by carefully synchronizing voltages applied to the deflection plates. This is called scanning.

During each horizontal sweep of the electron beam, the **grid** receives a signal voltage that limits the flow of electrons at each instant during the sweep; the more negative the grid voltage is, the more electrons are repelled and fewer pass through, producing a less bright spot on the screen. Thus, the varying grid voltage is responsible for the brightness of each spot on the screen. At the end of each horizontal sweep of the electron beam, the horizontal deflection voltage changes dramatically to bring the beam back to the opposite side of the screen, and the vertical voltage changes slightly so the beam begins a new horizontal sweep slightly below the previous one. The difference in brightness of the spots on the screen forms the “picture”.

Colour screens have red, green, and blue phosphors which glow when struck by the electron beam. The various brightnesses of adjacent red, green and blue phosphors (so close together we don't distinguish them) produce almost any colour. With 30 new frames or pictures every second (25 in countries with 50-Hz line voltage), a “moving picture” is displayed on the TV screen. The commercial movies present 24 frames per second as the film runs.

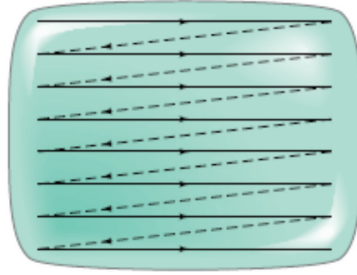

Fig. 7.14. Scanning across a CRT television screen in a succession of horizontal lines.

7.2.3 Trajectory of a charge moving in a cathode ray tube

If electrons enter an electric field in a CRT acting at right angles to their direction of motion, they are deflected from their original path. In Fig. 7.15, a p.d is applied between the plates *P* and *Q* of length *l*, creates an electric field of intensity *E*. Consider an electron of charge *e*, mass *m* and velocity *v* entering the field.

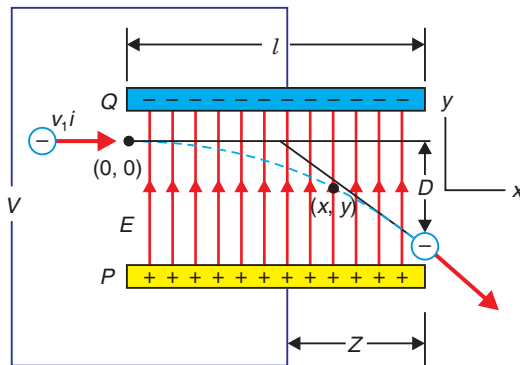

Fig. 7.15. Deflection of electrons in a magnetic field.

The value of *z* is measured from the centre of plates. Assume that the separation of plates is *d*.

Field intensity *E* is given by;

$$E = \frac{F}{e}$$

$$F = Ee \quad \text{..... Equation 7-18}$$

Potential gradient between plates is given by:

$$E = \frac{V}{d} \quad \text{..... Equation 7-19}$$

Substituting equation 7-19 into equation 7-18 gives:

$$F = \frac{Ve}{d} \quad \text{..... Equation 7-20}$$

Since *E* is vertical, there is no horizontal force acting on the electron. Hence, the horizontal velocity is not affected, i.e. it remains constant.

Vertical motion

Displacement y after time t is given by:

$$y = ut + \frac{1}{2}at^2 \quad \text{..... Equation 7-21}$$

Initially, $u = 0 \text{ m/s}$ because an electron enters in the field when it is moving horizontally.

$$y = \frac{1}{2}at^2 \quad \text{..... Equation 7-22}$$

From $F = ma$ and $F = Ee$;

$$a = \frac{Ee}{m} \quad \text{..... Equation 7-23}$$

Substituting equation 7-23 into equation 7-22 gives:

$$y = \frac{Eet^2}{2m} \quad \text{..... Equation 7-24}$$

Substituting equation 7-19 in equation 7-21 gives:

$$y = \frac{Vet^2}{2dm} \quad \text{..... Equation 7-25}$$

Horizontal motion

Displacement x after time t is given by:

$$x = vt \quad \text{..... Equation 7-26}$$

$$t = \frac{x}{v} \quad \text{..... Equation 7-27}$$

Substituting equation 7-26 into equation 7-25 gives:

$$y = \frac{Vex^2}{2mdv^2} \quad \text{..... Equation 7-28}$$

Note that equation 7-21 takes the form:

$$y = kx^2$$

where

$$k = \frac{Ve}{2dmv^2}$$

$$\therefore y \propto x^2 \quad \text{..... Equation 7-29}$$

Equation 7-29 shows that when electron is in the field, its path is parabolic and is called the **equation of trajectory**. When an electron just passes the plates, $x = l$. So,

$$y = \frac{Vel^2}{2mdv^2} \quad \text{..... Equation 7-30}$$

The beam then moves in a straight line after the plates. The time for which electron is between the plates is obtained from:

$$t = \frac{l}{v} \quad \text{..... Equation 7-31}$$

Thus, a component of velocity v gained in the direction of the field during this time is given by:

$$v_y = at$$

$$v_y = \frac{Vel}{dmv}$$

The angle θ at which the beam emerges from the field is given by:

$$\tan \theta = \frac{v_y}{v} \quad \text{..... Equation 7-32}$$

$$\tan \theta = \frac{Vel}{dmv^2} \quad \text{..... Equation 7-33}$$

$$\theta = \tan^{-1} \left(\frac{Vel}{dmv^2} \right) \quad \text{..... Equation 7-34}$$

The vertical deflection D of electron on the screen from initial direction of motion can be obtained by using the fact that it continues in a straight line after leaving the field.

From Fig. 7.9,
$$\tan \theta = \frac{D}{z} \quad \text{..... Equation 7-35}$$

Equating equation 7-34 and 7-32 gives:

$$\frac{D}{z} = \frac{Vel}{dmv^2}$$

$$D = \frac{Velz}{dmv^2} \quad \text{..... Equation 7-36}$$

EXAMPLE 7.6

A beam of electrons moving with velocity $1 \times 10^7 \text{ m/s}$ enters mid-way between two horizontal parallel plates P and Q in a direction parallel to the plates as shown on Fig.7-16. P and Q are 5 cm long and 2 cm apart, and have a p.dV applied between them.

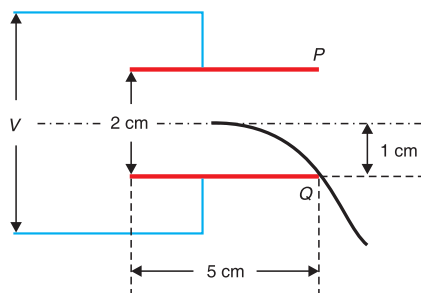

Fig. 7.16. Beam of charges entering mid-way between plates.

Calculate V if the beam is deflected so that it just grazes the edge of the lower plate Q . (Assume $\frac{e}{m} = 1.8 \times 10^{11} \text{ C/kg}$)

$$y = 1 \text{ cm} = 1 \times 10^{-2} \text{ m} \quad d = 2 \times 10^{-2} \text{ m} \quad \frac{e}{m} = 1.8 \times 10^{11} \text{ C/kg} \quad v = 1 \times 10^7 \text{ m/s}$$

From
$$y = \frac{V e l^2}{2 m d v^2};$$

$$V = \frac{2 m d v^2 y}{e l^2} = \frac{2 \times 2 \times 10^{-2} \times (1 \times 10^7)^2 \times 1 \times 10^{-2}}{1.8 \times 10^{11} \times (5 \times 10^{-2})^2}$$

$$V = 88.89 \text{ V}$$

Application Activity 7.2

- Fig. 7.17 shows two metal plates 2.0 cm long placed 5 mm apart. A fluorescent screen is placed 20.0 cm from one of the plates. An electron of kinetic energy $3.2 \times 10^{-6} \text{ J}$ is incident mid-way between the plates. Calculate the voltage applied across the plates to deflect the electron 2.1 cm on the screen. Assume that the electron moves through vacuum.

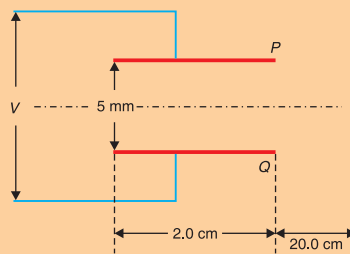

Fig. 7.17. Beam falling on the screen 20.0 cm away from the screen.

- In the diagram of Fig. 7.18, P and Q are parallel metal plates each of length $l = 4 \text{ cm}$. A p.d of 12 V is applied between P and Q . The space between P and Q is virtual. A beam of electrons of speed $1.0 \times 10^6 \text{ m/s}$ is directed mid-way between P and Q at right angles to the electric field between P and Q . Show that the electron beam emerges from the space between P and Q at an angle of 64.6° to the initial direction of the beam.

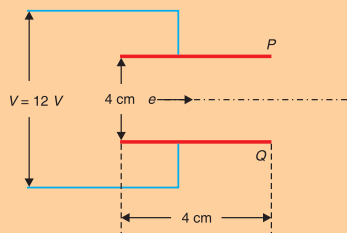

Fig. 7.18: Electron entering mid-way between parallel plates.

7.3 GRAVITATIONAL ENERGY

7.3.1 Newton's Law of Universal Gravitation

In 1687 Newton published his work on the law of gravity in his treatise *Mathematical Principles of Natural Philosophy*. Newton's law of universal gravitation states that

Every particle in the Universe attracts every other particle with a force that is directly proportional to the product of their masses and inversely proportional to the square of the distance between them.

If the particles have masses m_1 and m_2 and are separated by a distance r , (Fig.7.24) the magnitude of this gravitational force is

$$F = G \frac{m_1 m_2}{r^2} \quad \text{.....Equation 7-36}$$

where G is a constant, called the *universal gravitational constant*, that has been measured experimentally. Its value in SI units is

$$G = 6.67 \times 10^{-11} \text{ N} \cdot \text{m}^2 / \text{kg}^2$$

The form of the force law given by Equation 7.43 is often referred to as an inverse square law because the magnitude of the force varies as the inverse square of the separation of the particles.¹

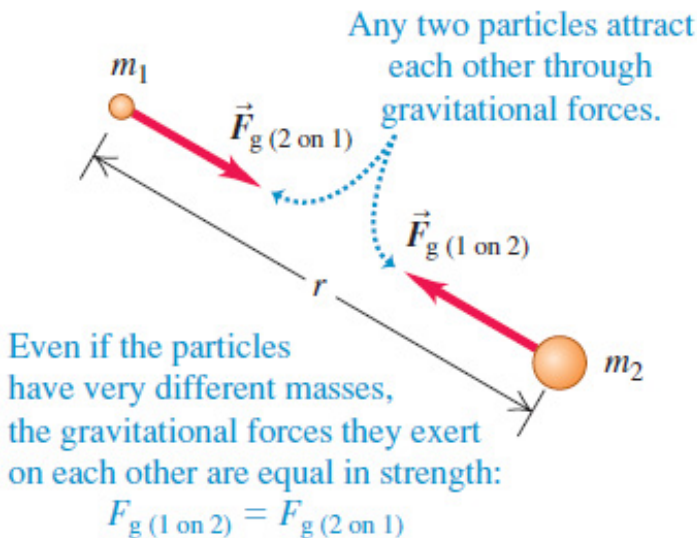

Fig.7. 19 The gravitational forces between two particles of masses m_1 and m_2 .

The magnitude of the force exerted by the Earth on a particle of mass m near the Earth's surface is

$$F = G \frac{M_e m}{R_e^2} \quad \dots\dots\dots \text{Equation 7-37}$$

Where $M_e = 5.98 \times 10^{24} \text{ kg}$ is the Earth's mass and $R_e = 6.378 \times 10^6 \text{ m}$ its radius
 This force is directed toward the center of the Earth.

7.3.2 Gravitational potential energy

Gravity is a conservative force, and we may define a potential energy associate with it. Recall that the work you must do to lift a mass m from one point to another is equal to the gain in potential energy. Work is done against gravity only when the displacement is radial. Going sideways to r requires no work. Suppose a mass m starts a distance r_1 from a mass M and we lift it out to $r_2 > r_1$.

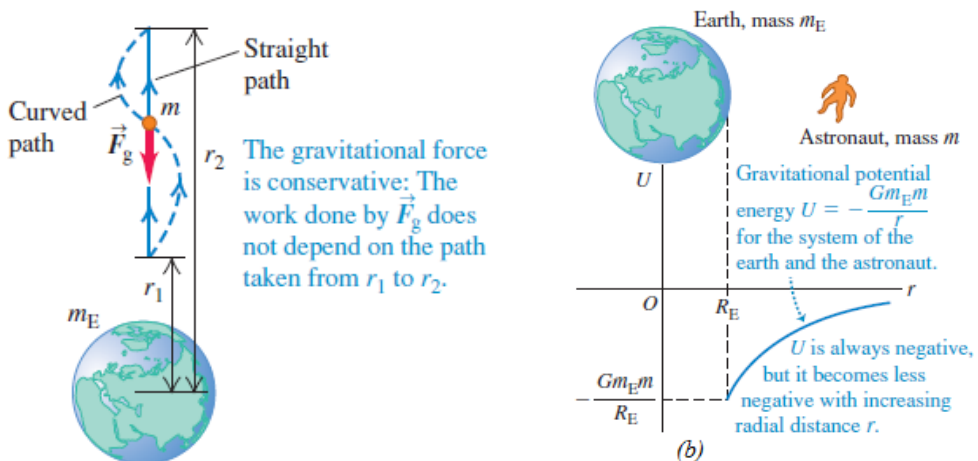

Fig.7. 20 (a) Work done on a body by the gravitational force as the body moves from radial coordinate r_1 to r_2 . (b) The gravitational potential energy depends on the distance r between the body of mass m and the center of the earth. When the body moves away from the earth, r increases, the gravitational force does negative work, and U increases (i.e., becomes less negative). When the body “falls” toward earth, r decreases, the gravitational work is positive, and the potential energy decreases (i.e., becomes more negative).

The work done by the gravitational force when the body moves directly away from or toward the center of the earth is given by:

$$W_{12} = \int_1^2 F dr = -GMm \int_1^2 \frac{dr}{r^2} = -GMm \left[-\frac{1}{r} \right]_1^2 = GMm \left(\frac{1}{r_2} - \frac{1}{r_1} \right) \quad \dots\dots \text{Equation 7-38}$$

We define the corresponding **gravitational potential energy** U so that

$$\Delta U_{21} = -W_{12} = -GMm\left(\frac{1}{r_2} - \frac{1}{r_1}\right) \quad \text{.....Equation 7-39}$$

The zero point of potential energy is arbitrary. Only differences in potential energy matter. If we choose $U = 0$ at ∞ , then the gravitational potential energy is

$$U = -\frac{GMm}{r} \quad \text{.....Equation 7-40}$$

This expression applies to the Earth–particle system where the particle is separated from the center of the Earth by a distance r , provided that $r \geq R_e$. The result is not valid for particles inside the Earth, where $r < R_e$.

The work done in bringing a unit mass from a given point to infinity in gravitational field, against the gravitational field, is defined as the gravitational potential (V) at that point.

$$V = -\frac{GM}{r} \quad \text{.....Equation 7-41}$$

Frequently we are interested in objects a small distance h above the surface of the earth, where $h \ll R_e$. If we take $r_1 = R_e$ and $r_2 = R_e + h$ then

$$\Delta U = -GM_e m \left(\frac{1}{R_e + h} - \frac{1}{R_e} \right) = -GM_e m \left(\frac{R_e - R_e - h}{(R_e + h)R_e} \right) \approx m \frac{GM_e}{R_e} = mgh$$

This approximation is useful near the **surface of the earth**.

If the potential at infinity is taken as zero by convention, the negative sign indicates that the potential at infinity (zero) is higher than the potential close to the earth. On the earth’s surface, of radius R_e , we therefore obtain:

$$U(R_e) = -\frac{GMm}{R_e} \quad \text{.....Equation 7-42}$$

The gravitational potential energy of a body of mass m due to the Earth’s gravitational field is zero at infinity; when a body moves from infinity to a point in the gravitational field, its potential energy decreases and kinetic energy increases as shown in Fig.7.32b. Although Equation 7.42 was derived for the particle–Earth system, it can be applied to any two particles. That

is, the gravitational potential energy associated with any pair of particles of masses m_1 and m_2 separated by a distance r is

$$U(r) = -\frac{Gm_1m_2}{r} \quad \text{.....Equation 7-43}$$

When two particles are at rest and separated by a distance r , an external

agent has to supply energy at least equal to $U = -\frac{Gm_1m_2}{r}$ in order to separate the particles to an infinite distance.

It is therefore convenient to think of the absolute value of the potential energy as the *binding energy* of the system. If the external agent supplies energy greater than the binding energy, the excess energy of the system will be in the form of kinetic energy when the particles are at an infinite separation.

Example 7.7: Binding energy

1. Calculate the binding energy of the earth-sun system neglecting the effect of the presence of other planets and satellites. Mass of earth = 6×10^{24} , mass of sun = 3.3×10^5 times the mass of earth and the distance between earth and sun = 1.5×10^8 km.

Answer:

The binding energy is the absolute value of the potential energy

$$W = -\frac{GMm}{R} = \frac{(6.67 \times 10^{-11} \text{ N} \cdot \text{m}^2 / \text{kg}^2)(3.3 \times 10^5 \times 6 \times 10^{24} \text{ kg})(6 \times 10^{24} \text{ kg})}{1.5 \times 10^8 \text{ m}} = 5.28 \times 10^{33} \text{ J}$$

Gravitational Potential Energy of a System

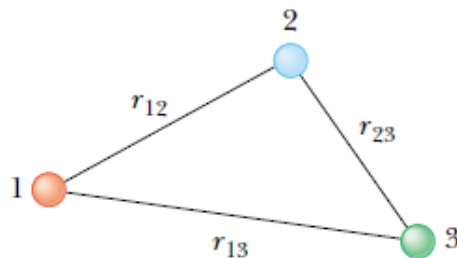

Fig.7. 21 Three interacting particles

We can extend this concept to three or more particles. In this case, the total potential energy U_{tot} of the system is the sum over all pairs of particles. Each pair contributes a term of the form given by Equation 7.36. For example, if the system contains three particles, as in Fig.7.29, we find that by **superposition principle**

$$U_{tot} = U_{12} + U_{13} + U_{23} = -G\left(\frac{m_1m_2}{r_{12}} + \frac{m_1m_3}{r_{13}} + \frac{m_2m_3}{r_{23}}\right) \quad \text{.....Equation 7-45}$$

The absolute value of U_{tot} represents the work needed to separate the particles by an infinite distance.

Example 7.8: Superposition of gravitational potential energy

1. A system consists of three particles, each of mass 5.00 g, located at the corners of an equilateral triangle with sides of 30.0 cm. (a) Calculate the potential energy of the system. (b) If the particles are released simultaneously, where will they collide?

Answer

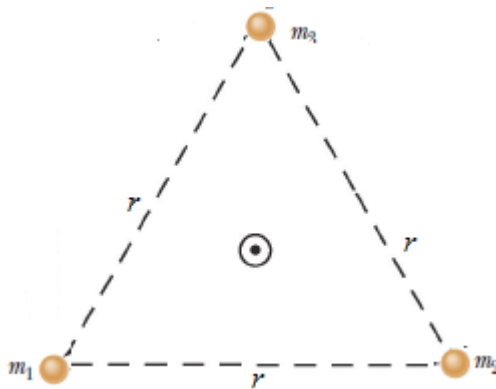

Fig.7. 21 A system consisting of three particles.

The gravitational potential energy of the system is the sum of the gravitational potential energies of all three pairs of particles

$$U_{tot} = -G\left(\frac{m_1m_2}{r_{12}} + \frac{m_1m_3}{r_{13}} + \frac{m_2m_3}{r_{23}}\right) = -\frac{3Gm^2}{r} = \frac{3(6.67 \times 10^{-11})(5.00 \times 10^{-3})^2}{30.0 \times 10^{-2}} = 0.556 \times 10^{-15} \text{ J}$$

7.3.3 Kinetic energy of satellite

Force towards center: $F = \frac{mv^2}{R} = \frac{GMm}{R^2}$ where v is the speed in the orbit of radius R .

Kinetic energy in orbit: $K = \frac{1}{2}mv^2 = \frac{GMm}{2R}$ Equation 7-45

So from this relation, the potential energy of the mass in orbit is numerically twice its kinetic energy and opposite sign:

$$K = \frac{GMm}{2R} = -\frac{U}{2}$$
Equation 7-46

The K of satellite increases when it falls to an orbit of smaller radius, that is, the satellite speeds up. This apparent abnormality is explained by the fact that the U decreases by twice as much as the K increases, from (Eq.7.46)

7.3.4 Total energy in orbit

The total energy of a satellite in circular orbit is the sum of its potential energy and its kinetic energy.

$$E = K + U = \frac{GMm}{2R} - \frac{GMm}{R} = -\frac{GMm}{2R} = \frac{U}{2}$$
Equation 7-47

The total mechanical energy in a circular orbit is negative and equal to one-half the potential energy. Increasing the orbit radius r means increasing the mechanical energy (that is, making E less negative). Fig.7.35 shows the variation of K , U , and E with r for a satellite moving in a circular orbit about a massive central body. Note that as r is increased, the kinetic energy (and thus also the orbital speed) decreases.

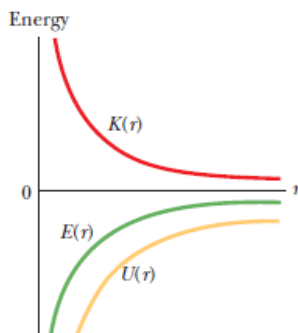

Fig.7. 23 The variation of kinetic energy K , potential energy U , and total energy E with radius r for a satellite in a circular orbit. For any value of r , the values of U and E are negative, the value of K is positive, and $E = -K$. As $r \rightarrow \infty$ all three energy curves approach a value of zero.

If the satellite is in a relatively low orbit that encounters the outer fringes of earth’s atmosphere, mechanical energy decreases due to negative work done by the force of air resistance; as a result, the orbit radius decreases until the satellite hits the ground or burns up in the atmosphere.

Example 7.9

1. A satellite of mass 450 kg orbits the Earth in a circular orbit at 6.83 Mm above the Earth's surface. Find: (a) the potential energy (b) the kinetic energy and (c) the total energy of the satellite

Answer

(a) the distance between the satellite and the center of the Earth is

$$R = R_e + h = 6.37 \times 10^6 + 6.83 \times 10^6 = 13.2 \times 10^6 \text{ m}$$

The potential energy:

$$U = -\frac{GMm}{R} = \frac{(6.67 \times 10^{-11} \text{ N} \cdot \text{m}^2 / \text{kg}^2)(5.98 \times 10^{24} \text{ kg})(450 \text{ kg})}{13.2 \times 10^6 \text{ m}} = -13.6 \times 10^9 \text{ J}$$

(b) the kinetic energy:

$$K = \frac{GMm}{2R} = \frac{(6.67 \times 10^{-11} \text{ N} \cdot \text{m}^2 / \text{kg}^2)(5.98 \times 10^{24} \text{ kg})(450 \text{ kg})}{2 \times 13.2 \times 10^6 \text{ m}} = 6.80 \times 10^9 \text{ J}$$

(c) The total energy:

$$E = K + U = -13.6 \times 10^9 \text{ J} + 6.80 \times 10^9 \text{ J} = -6.80 \times 10^9 \text{ J}$$

$$\text{or } E = -\frac{GMm}{2R} = \frac{(6.67 \times 10^{-11} \text{ N} \cdot \text{m}^2 / \text{kg}^2)(5.98 \times 10^{24} \text{ kg})(450 \text{ kg})}{2 \times 13.2 \times 10^6 \text{ m}} = -6.80 \times 10^9 \text{ J}$$

The total energy equals the negative of the kinetic energy.

Escape speed:

Near the surface of the Earth, the force of attraction between the Earth and some object is constant and equal to mg which is independent of the height of the object above the Earth's surface. The gravitational field near the surface of the Earth is said to be uniform.

If we project an object vertically upward with initial speed in uniform gravitational field, it will rise to a maximum height given by the law of conservation of mechanical energy:

$$\frac{1}{2}mu^2 + 0 = mgh$$

However, we know from Newton's law of gravity that gravitational of the

Earth is not uniform, but decreases as $\frac{1}{r^2}$.

If we project an object upward with a very large initial speed so that the object moves a distance comparable to the radius of the Earth, we must take into account the decrease in the gravitational force on the object to calculate correctly the maximum height the object attains.

$$\frac{1}{2}mu^2 - \frac{GMm}{R_e} = \frac{1}{2}mv^2 - \frac{GMm}{R} \quad \dots\dots\dots\text{Equation 7-48}$$

The minimum speed the object must have at the Earth's surface in order to escape from the influence of the Earth's gravitational field is **escape speed**. Traveling at this minimum speed, the object continues to move farther and farther away from the Earth as its speed asymptotically approaches zero.

Letting in Equation of escape velocity, $u = v_e$, $v = 0$ and taking $R = \infty$, we obtain

$$\frac{1}{2}mu^2 - \frac{GMm}{R_e} = 0 \Leftrightarrow v_e = \sqrt{\frac{2GM}{R_e}} \quad \dots\dots\dots\text{Equation 7-4}$$

Note that this expression for v_e is independent of the mass of the object. In other words, a spacecraft has the same escape speed as a molecule. Furthermore, the result is independent of the direction of the velocity and ignores air resistance.

If the object is given an initial speed equal to v_e , its total energy is equal to zero. This can be seen by noting that when the object's kinetic energy and its potential energy are both zero.

Example 7.10

1. Calculate the escape speed from the Earth for a 5 000 kg spacecraft, and determine the kinetic energy it must have at the Earth's surface in order to move infinitely far away from the Earth.

Answer

$$v_e = \sqrt{\frac{2GMm}{R_e}} = \sqrt{\frac{2(6.67 \times 10^{-11} \text{ m}^3 / \text{s}^2 \cdot \text{kg}^2)(5.98 \times 10^{24} \text{ kg})}{6.37 \times 10^6 \text{ m}}} = 11.2 \text{ km / s}$$

The kinetic energy of the spacecraft is

$$K = \frac{1}{2}mv_e^2 = \frac{1}{2}(5\,000 \text{ kg})(11.2 \times 10^3 \text{ km / s})^2 = 3.14 \times 10^{11} \text{ J}$$

2. What if we wish to launch a 1 000 kg spacecraft at the escape speed? How much energy does this require?

Answer

From Equation $v_e = \sqrt{\frac{2GM}{R}}$, the mass of the object moving with the escape speed does not appear.

Thus, the escape speed for the 1 000 kg spacecraft is the same as that for the 5 000 kg spacecraft

The only change in the kinetic energy is due to the mass, so the 1 000 kg spacecraft will require one fifth of the energy of the 5 000 kg spacecraft:

$$K = \frac{1}{2} m v_e^2 = \frac{3.14 \times 10^{11}}{5} = 6.28 \times 10^{10} \text{ J}$$

7.3.5 Relation between electric and gravitational field

There are many similarities between Coulomb's law and Newton's law of universal gravitation:

- Both are inverse square laws that are also proportional to the product of another quantity; for gravity it is the product of two masses, and for the electric force it is the product of the two charges.
- The forces act along the line joining the centres of the masses or charges.
- The magnitude of the force is the same as the force that would be measured if all the mass or charge is concentrated at a point at the centre of the sphere.

Therefore, distance in both cases is measured from the centres of the spheres. In both cases we are assuming that r is longer than the radius of the object. However, the two forces also differ in some important ways:

- The electric force can attract or repel, depending on the charges involved, whereas the gravitational force can only attract.
- The universal gravitational constant, $G = 6.673 \times 10^{-11} \text{ N} \cdot \text{m}^2 / \text{kg}^2$, is very small, meaning that in many cases the gravitational force can be ignored unless at least one of the masses is very large. In contrast, Coulomb's constant, $k = 9.0 \times 10^9 \text{ N} \cdot \text{m}^2 / \text{C}^2$, is a very large number (over one hundred billion billion times bigger than G), implying that even small charges can result in noticeable forces.
- Just as a mass can be attracted gravitationally by more than one body at once, so a charge can experience electric forces from more than one body

at once. Experiments have shown that the force between two charges can be determined using Coulomb's law independently of the other charges present, and that the net force on a single charge is the vector sum of all these independently calculated electric forces acting on it.

Application Activity 7.3

- An asteroid, headed directly toward Earth, has a speed of 12 km/s relative to the planet when the asteroid is 10 Earth radii from Earth's center. Neglecting the effects of Earth's atmosphere on the asteroid, find the asteroid's speed v_f when it reaches Earth's surface.
- A playful astronaut releases a bowling ball, of mass $m = 7.20 \text{ kg}$, into circular orbit about Earth at an altitude h of 350 km.
 - What is the mechanical energy E of the ball in its orbit?
 - What is the mechanical energy E_o of the ball on the launchpad at the Kennedy Space Center (before launch)? From there to the orbit, what is the change ΔE in the ball's mechanical energy?
- What is the force of gravity acting on a 2000 kg spacecraft when it orbits two Earth radii from the Earth's center (that is, a distance $R_e = 6380 \text{ km}$ above the Earth's surface)? The mass of the Earth is $M_e = 5.98 \times 10^{24} \text{ kg}$

END OF UNIT ASSESSMENT

- Four particles of masses m , $2m$, $3m$ and $4m$ are kept in sequence at the corners of a square of side a . Find the magnitude of gravitational force acting on a particle of mass m placed at the centre of the square.

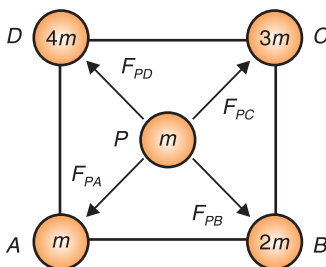

Fig. 7.24. System of four masses.

- Mass M is divided into two parts xM and $(1-x)M$. For a given separation, the value of x for which the gravitational attraction between the two

pieces becomes maximum. Find this maximum value of x .

3. Three identical point masses, each of mass 1 kg lies in the $x - y$ plane at points $(0, 0)$, $(0, 0.2 \text{ m})$ and $(0.2 \text{ m}, 0)$. Find the net gravitational force on the mass at the origin.

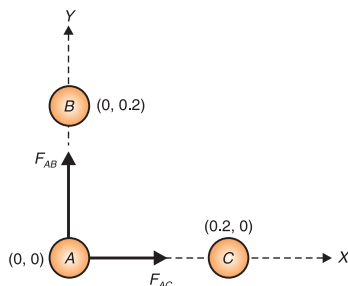

Fig. 7.25. Three identical masses in space.

4. Two positive charges sit in an (x, y) -coordinate system. The first one has charge $q_1 = 0.40 \mu\text{C}$ and sits at $(-0.30 \text{ m}, 0)$. The second one has charge $q_2 = 0.30 \mu\text{C}$ and sits at $(0, +0.30 \text{ m})$. Find the *electric potential* at the origin.
5. (a) Find the electric potential energy of the system of two charges shown in the Figure 7.26.

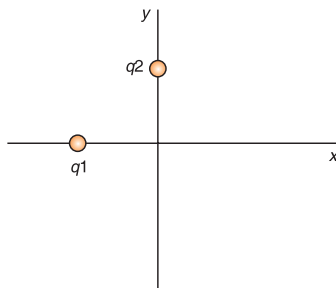

Fig. 7.26. System of charges.

- (b) Find the electric potential energy of the system if a third charge $q_3 = -0.10 \mu\text{C}$ is placed at the origin.
6. Two rectangular copper plates are oriented horizontally with one directly above the other. They are separated by a distance of 25 mm. The plates are connected to the terminals a 5.0 volt flashlight battery. The positive plate (the one at the higher electric potential) is at the bottom; the negative plate (the one at the lower electric potential) is at the top.

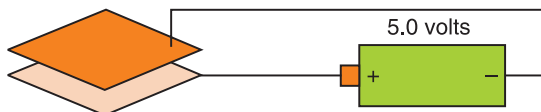

Fig. 7.27. Two rectangular copper plates are oriented horizontally with a supply.

If an electron is placed on the upper plate, then released, with what speed will it strike the lower plate? Use conservation of energy.

7. A charge of $+2.82 \mu\text{C}$ sits in a uniform electric field of 12.0 N/C directed at an angle of 60° above the $+x$ axis. The charge moves from the origin (point A) to the point $(1.40 \text{ m}, 0)$ (point B) on the x -axis.

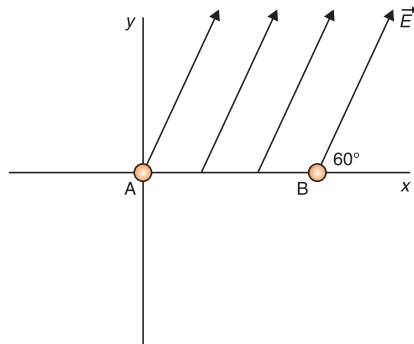

Fig. 7.28. System of forces.

- a. Find the force exerted on the charge by the electric field.
- b. Find the work done on the charge by the electric field as the charge moves from A to B.
- c. Find the change in the charge's electric potential energy as it moves from A and B.
- d. Find the electric potential difference between points A and B.

UNIT SUMMARY

Electric Field and Electric Potential Due to a Point Charge

The direction of electric field is taken to be the direction of the force it would exert on a positive test charge.

$$\text{potential } V = \frac{\text{Work done}}{\text{Unit charge}} \text{ or Potential } V = \frac{\text{Energy to be applied}}{\text{Unit charge}}$$

$$V = -\frac{q}{4\pi\epsilon_0 r}$$

Electric Potential Energy and Potential Difference

The work done by a conservative force in moving an object between any two positions is independent of the path taken. Hence, we define the potential energy for electrostatic force mathematically as:

Potential Energy $U =$ Work done on a Charge

And the change in electrical energy between two points A and B is given by:

$$\Delta U = \frac{q^2}{4\pi\epsilon_0\epsilon_r} \left(\frac{1}{r_A} - \frac{1}{r_B} \right)$$

$$U_B - U_A = -qEd$$

Equipotential Lines and Surfaces

An equipotential surface is one on which all points are at the same potential. **An equipotential surface must be perpendicular to the electric field at any point.**

Potential due to Electric Dipole

Unlike electric field lines, which start and end on electric charges, equipotential lines and surfaces are always continuous closed curved.

Conservation of Electrical Energy

At the instant at which the field is applied, the motionless test charge has zero kinetic energy, and its electric potential energy is at a maximum. Then, the charge accelerates, and its kinetic energy (from motion) increases as its potential energy decreases. The sum of energies is always constant.

$$E_{pot} + E_{kin} = \text{constant}$$

Cathode Ray Tube (CRT)

The CRT is a vacuum tube in which a beam of electrons is accelerated and deflected under the influence of electric or magnetic fields.

These electrons, if left undisturbed, travel in a straight-line path until they strike the screen of the CRT, which is coated with a material that emits visible light when bombarded with electrons.

TV and Computer Monitors

In TV and computer monitors, the CRT electron beam sweeps over the screen in the manner of carefully synchronized voltages applied to the deflection plates and is called scanning.

Trajectory of a charge moving in a cathode ray tube

The equation of motion of a charge in a field is calculated by considering vertical and horizontal displacements and is given by:

$$y = \frac{Vex^2}{2mdv^2}$$

$$\therefore y \propto x^2$$

This equation shows that when electron is in the field, its path is parabolic and is called the **equation of trajectory**.

The vertical deflection D of electron on the screen from initial direction of motion can be obtained by using equation:

$$D = \frac{Velz}{dmv^2}$$

Electrodynamics

When the velocities of the charged particles under consideration become comparable with the speed of light, corrections involving the theory of relativity must be made; this branch of the theory is called **relativistic electrodynamics**.

Gravitational Potential

The gravitational potential V at a point is defined numerically as work done in taking a uniform mass from infinity to that point.

$$V = -\frac{GM_e}{R}$$

Escape Velocity for a Planet

If the rocket is fired from the surface of the earth with velocity v such that it just escapes from the influence of the earth's gravitational pull. Then this velocity is called **escape velocity**.

$$\begin{aligned}v &= \sqrt{2gR_e} \\v &= \sqrt{2 \times 9.8 \times 6.4 \times 10^6} \\&= 11.2 \times 10^3 \text{ m/s} = 11.2 \text{ km/s}\end{aligned}$$

Energy Conservation in Gravitational Fields

Conservation of energy tells us that the total energy of the system is conserved, and in this case, the sum of kinetic and potential energy must be constant. This means that every change in the kinetic energy of a system must be accompanied by an equal but opposite change in the potential energy.

$$\text{Total energy } E = k.e. + p.e.$$

$$E = -\frac{GM_e m}{2r}$$

UNIT 8

MOTION IN ORBITS



Key unit competence: Evaluate Newton's law of gravitation and apply Kepler's laws of planetary motion.

Unit Objectives:

By the end of this unit I will be able to;

- ◇ Explain the terms, concept and characteristics of waves properly.
- ◇ Explain the properties of waves.
- ◇ Explain the behavior of waves in vibrating strings and applications of waves properly.

Introductory Activity

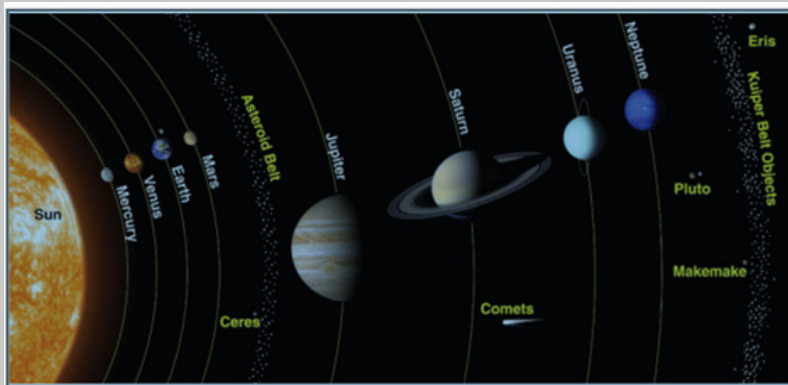

People have always enjoyed viewing stars and planets on clear, dark nights. It is not only the beauty and variety of objects in the sky that is so fascinating, but also the search for answers to questions related to the patterns and motions of those objects.

Until the late 1700s, Jupiter and Saturn were the only outer planets identified in our solar system because they were visible to the naked eye. Combined with the inner planets the solar system was believed to consist of the Sun and six planets, as well as other smaller bodies such as moons. Some of the earliest investigations in physical science started with questions that people asked about the night sky.

- i) Based on the scenario above and the observation from the picture. Briefly summarize what is illustrated in the picture.
- ii) What is the name of belt separating the largest and smallest planets?
- iii) Explain why you think the moon doesn't fall on the earth.
- iv) Why don't we fly off into space rather than remaining on the Earth's surface? Explain your idea.
- v) Explain why planets move across the sky.

8.1. INTRODUCTION

Gravity is the mysterious force that makes everything fall down towards the Earth. But after research it has turned out that all objects have gravity. It's just that some objects, like the Earth and the Sun, have a stronger gravity than others. How much gravity an object has depends its mass. It also depends on how close you are to the object. The closer you are, the stronger the gravity.

Gravity is very important to our everyday lives. Without Earth's gravity we would fly right off it. If you kicked a ball, it would fly off forever. While it might be fun to try for a few minutes, we certainly can't live without gravity. Gravity also is important on a larger scale. It is the Sun's gravity that keeps the Earth in orbit around the Sun. Life on Earth needs the Sun's light and warmth to survive. Gravity helps the Earth to stay at just the right distance from the Sun, so it's not too hot or too cold.

8.2. NEWTON'S LAW OF GRAVITATION

This is also called *the universal law of gravitation or inverse square law*. It states that “*the gravitational force of attraction between two masses m_1 and m_2 is directly proportional to the product of masses and inversely proportional to the square of their mean distance apart.*”

Remember two objects exert equal and opposite force of gravitation on each other.

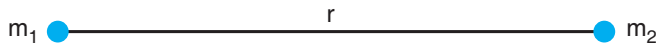

Fig. 8.1: Gravitational force between two masses

Mathematically:

$$F \propto \frac{m_1 m_2}{r^2}$$

$$F = \frac{G m_1 m_2}{r^2} \quad \text{.....Equation 8-1}$$

where $G = 6.7 \times 10^{-11} \text{ N m}^2/\text{kg}^2$ and is called the universal gravitational constant.

Notes:

- The value of G in the laboratory was first determined by Cavendish using the torsional balance.
- The value of G is $6.67 \times 10^{-11} \text{ N. m}^2. \text{ kg}^{-2}$ in S.I.
- Dimensional formula $[M^{-1}L^3T^{-2}]$.
- The value of G does not depend upon the nature and size of the bodies.
- It also does not depend upon the nature of the medium between the two bodies.
- As G is very small hence gravitational forces are very small, unless one (or both) of the masses is huge.

Properties of Gravitational Force

- It is always attractive in nature while electric and magnetic force can be attractive or repulsive.
- It is independent of the medium between the particles while electric and magnetic forces depend on the nature of the medium between the particles.
- It holds good over a wide range of distances. It is found true for interplanetary to interatomic distances.
- It is a central force, i.e. it acts along the line joining the centres of two interacting bodies.
- It is a two-body interaction, i.e. gravitational force between two particles is independent of the presence or absence of other particles; so, the principle of superposition is valid, i.e. force on a particle due to number of particles is the resultant of forces due to individual particles, i.e. $\vec{F} = \vec{F}_1 + \vec{F}_2 + \vec{F}_3 + \dots$
- On the contrary, nuclear force is a many-body interaction.
- It is the weakest force in nature : For example $F_{\text{nuclear}} > F_{\text{electromagnetic}} > F_{\text{gravitational}}$
- The ratio of gravitational force to electrostatic force between two electrons is of the order of 10^{-43} .
- It is a conservative force, i.e. work done by it is path independent or work done in moving a particle round a closed path under the action of gravitational force is zero.
- It is an action reaction pair, i.e. the force with which one body (say, earth) attracts the second body (say, moon) is equal to the force with which moon attracts the earth. This is in accordance with Newton's third law of motion.

8.3. KEPLER'S LAWS OF PLANETARY MOTION

Planets are large natural bodies rotating around a star in definite orbits. The planetary system of the star sun, called **solar system**, consists of eight planets, viz. Mercury, Venus, Earth, Mars, Jupiter, Saturn, Uranus, and Neptune. Out of these planets mercury is the smallest, closest to the sun. Jupiter is the largest and has the maximum number of moons. Venus is closest to the earth and the brightest planet. Kepler, after a life time study, worked out three empirical laws which govern the motion of these planets and are known as Kepler's laws of planetary motion. These are stated below.

1st Law: This law is called the law of orbits and it states that planets move in ellipses with the sun as one of their foci. It can also be stated that planets describe ellipses about the sun as one focus. (Fig. 8.2)

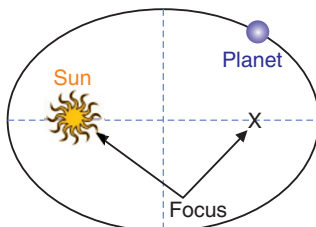

Fig. 8.2: Kepler's first law

2nd Law: This is called the law of areas and states that the line joining the sun and the planet sweeps out equal areas in equal periods of time. (Fig. 8.3)

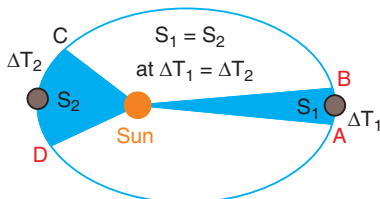

Fig. 8.3: Kepler's second law

According to the law, if the time taken to move from A to B equals the time taken to move from C to D.

Then: $S_1 = S_2$ Equation 8-2

3rd Law: The law of periods states that the square of the period T of revolution of any planet is proportional to the cube of its mean distance R from the sun. (Fig. 8.4)

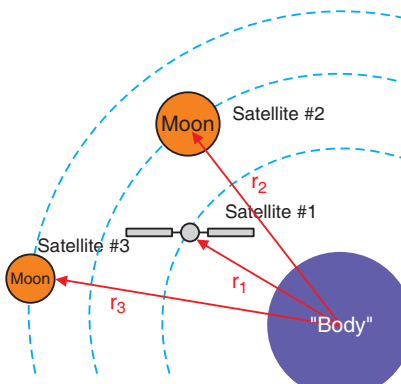

Fig. 8.4: Kepler's third law

$$T^2 \propto R^3$$

8.4. VERIFICATION OF KEPLER'S THIRD LAW OF PLANETARY MOTION

Assuming that a planet's orbit is circular (which is not exactly correct but is a good approximation in most cases), then the mean distance from the sun is constant –radius. Suppose, a planet of mass m_2 moving around the sun of mass m_1 . If the motion of the planet is circular, there are two types of forces:

- (a) Gravitational force of attraction F_1 between the sun and the planet,

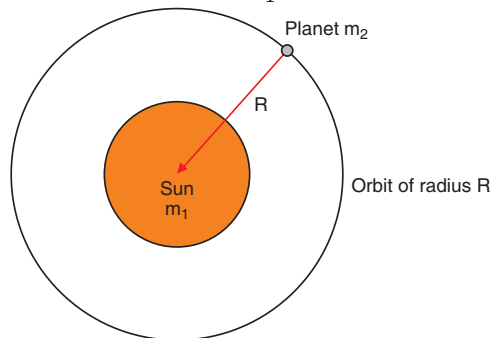

Fig. 8.5: Gravitational force of attraction of the sun and the planet

$$\text{It is given by } F_1 = \frac{Gm_1m_2}{R^2} \quad \text{..... Equation 8-3}$$

- (b) Centripetal force F_2 responsible for keeping the planet moving in a circular motion around the sun.

$$F_2 = \frac{m_2v^2}{R}$$

For the planet to move around the sun in orbit of constant radius:

$$F_1 = F_2$$

$$\frac{m_2v^2}{R} = \frac{Gm_1m_2}{R^2}$$

$$v^2 = \frac{Gm_1}{R}$$

But linear velocity $v = \omega R$ and $\omega = \frac{2\pi}{T}$ where ω is the angular velocity

$$\text{So, } \frac{4\pi^2R^2}{T^2} = \frac{Gm_1}{R}$$

$$R^3 = kT^2 \quad \text{..... Equation 8-4}$$

$$\text{This is true that } R^3 \propto T^2 \quad \text{..... Equation 8-5}$$

EXAMPLE 8.1:

The distance of a planet from the sun is 5 times the distance between the earth and the sun. What is the time period of revolution of the planet?

Solution:

According to Kepler's law

$$R^3_{\text{earth}} \propto T^2_{\text{earth}}$$

$$R^3_{\text{planet}} \propto T^2_{\text{planet}}$$

Dividing these equations and making T_{planet} the subject gives

$$T^2_{\text{planet}} = T^2_{\text{earth}} \cdot R^3_{\text{planet}} / R^3_{\text{earth}}$$

But $R_{\text{planet}} = 5 R_{\text{earth}}$ which gives

$$5^3 R^3_{\text{earth}} = R^3_{\text{planet}}$$

$$T^2_{\text{planet}} = T^2_{\text{earth}} \cdot (5)^3$$

But $T_{\text{earth}} = 1$ year

$$T_{\text{planet}} = (5)^{\frac{3}{2}} \times T_{\text{Earth}}$$

$$T_{\text{planet}} = (5)^{\frac{3}{2}} \times 1 \text{ year} = 5^{\frac{3}{2}} \text{ years}$$

EXAMPLE 8.2:

The planet is revolving around the sun as shown in elliptical path.

The correct option is:

- The time taken in travelling DAB is less than that for BCD .
- The time taken in travelling DAB is greater than that for BCD .
- The time taken in travelling CDA is less than that for ABC .
- The time taken in travelling CDA is greater than that for ABC .

Solution:

- When the planet passes nearer to sun, it moves fast and vice versa. Hence, the time taken in travelling DAB is less than that for BCD .

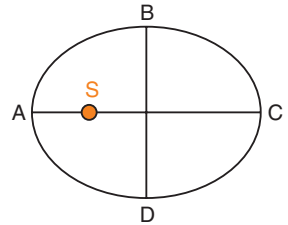

Fig. 8.6: Planet revolving around the sun.

Background information:

Kepler's third law (the Harmonic Law), relates the orbital period of a planet (that is, the time it takes a planet to complete one orbit) to its mean distance from the Sun. This law states that the closest planets travel at the greatest speeds and have the shortest orbital periods.

	Mercury	Earth	Ratio
Mass (10 ²⁴ kg)	0.33011	5.9724	0.0553
Equatorial radius (km)	2439.7	6378.1	0.383
Polar radius (km)	2439.7	6356.8	0.384
Volumetric mean radius (km)	2439.7	6371.0	0.383
	Venus	Earth	Ratio
Mass (10 ²⁴ kg)	4.8675	5.9724	0.815
Equatorial radius (km)	6051.8	6378.1	0.949
Polar radius (km)	6051.8	6356.8	0.952
Volumetric mean radius (km)	6051.8	6371.0	0.950
	Moon	Earth	Ratio
Mass (10 ²⁴ kg)	0.07346	5.9724	0.0123
Equatorial radius (km)	1738.1	6378.1	0.2725
Polar radius (km)	1736.0	6356.8	0.2731
Volumetric mean radius (km)	1737.4	6371.0	0.2727
	Mars	Earth	Ratio
Mass (10 ²⁴ kg)	0.64171	5.9724	0.107
Equatorial radius (km)	3396.2	6378.1	0.532

Polar radius (km)	3376.2	6356.8	0.531
Volumetric mean radius (km)	3389.5	6371.0	0.532
	Jupiter	Earth	Ratio
Mass (10²⁴ kg)	1,898.19	5.9724	317.83
Equatorial radius (1 bar level) (km)	71,492	6,378.1	11.209
Polar radius (km)	66,854	6,356.8	10.517
Volumetric mean radius (km)	69,911	6,371.0	10.973
	Saturn	Earth	Ratio
Mass (10²⁴ kg)	568.34	5.9724	95.16
Equatorial radius (1 bar level) (km)	60,268	6,378.1	9.449
Polar radius (1 bar level) (km)	54,364	6,356.8	8.552
Volumetric mean radius (km)	58,232	6,371.0	9.140
	Uranus	Earth	Ratio
Mass (10²⁴ kg)	86.813	5.9724	14.54
Equatorial radius (1 bar level) (km)	25,559	6,378.1	4.007
Polar radius (1 bar level) (km)	24,973	6,356.8	3.929
Volumetric mean radius (km)	25,362	6,371.0	3.981
	Neptune	Earth	Ratio
Mass (10²⁴ kg)	102.413	5.9724	17.15
Equatorial radius (1 bar level) (km)	24,764	6,378.1	3.883

Polar radius (1 bar level) (km)	24,341	6,356.8	3.829
Volumetric mean radius (km)	24,622	6,371.0	3.865
	Pluto	Earth	Ratio
Mass (10²⁴ kg)	0.01303	5.9724	0.0022
Equatorial radius (km)	1187	6378.1	0.186
Polar radius (km)	1187	6356.8	0.187
Volumetric mean radius (km)	1187	6371.0	0.186

Source of data: lunar and planetary science by National Aeronautics and Space Administration (NASA)

Use the data provided in the tables above and find the orbital period for each orbital radius for each planet. Enter the data into spreadsheets and plot line graphs for the data, with each planet's orbital radius on the X-axis and its orbital period on the Y-axis.

Planet	Orbital Radius (X)	Orbital Period (Y)

Describe any general trends you see:

- Is there a systematic relationship between period and radius for the planets for each case?
- How would you describe this relationship in words?
- Is the relationship you observe consistent with Kepler's third law?
- How could you improve your test for consistency?

Application Activity 8.1

Using the cross and down clues write the correct words in the numbered grid below.

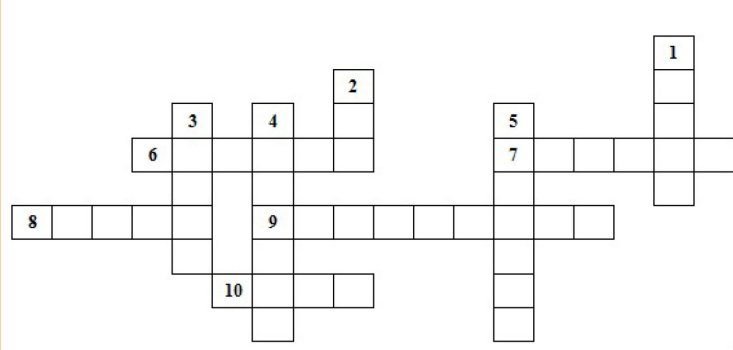

Across

6. The second largest planet with many rings.
7. This planet's blue color is the result of absorption of red light by methane in the upper atmosphere.
8. A small body that circles the Sun with a highly elliptical orbit.
9. An object in orbit around a planet.
10. A large cloud of dust and gas which escapes from the nucleus of an active comet.

DOWN

1. It is the brightest object in the sky except for the Sun and the Moon.
2. The largest object in the solar system.
3. The only planet whose English name does not derive from Greek/Roman mythology.
4. An area seen as a dark spot on the photosphere of the Sun.
5. This planet is more than twice as massive as all the other planets combined.

8.5. ACCELERATION DUE TO GRAVITY AT THE SURFACE OF THE EARTH

The force of attraction exerted by the earth on a body is called gravitational pull or gravity. We know that when force acts on a body, it produces acceleration. Therefore, a body under the effect of gravitational pull must accelerate. The acceleration produced in the motion of a body under the effect of gravity is called acceleration due to gravity (g). Consider a body of mass m lying on the surface of earth. Then gravitational force on the body is given by:

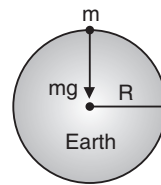

Fig. 8.7: Acceleration due to gravity at the surface of the earth.

$$F = \frac{GMm}{R^2} \quad \text{..... Equation 8-6}$$

where M = mass of the earth and R = radius of the earth.

If g is the acceleration due to gravity, then the force on the body due to earth is given by

$$\text{Force} = \text{mass} \times \text{acceleration}$$

or
$$F = mg \quad \text{..... Equation 8-7}$$

From equation 8-6 and 8-7 we have $mg = \frac{GMm}{R^2}$

$$\therefore g = \frac{GM}{R^2}$$

$$\Rightarrow g = \frac{G}{R^2} \left(\frac{4}{3} \pi R^3 \rho \right) \quad [\text{As mass } (M) = \text{volume } \frac{4}{3} \pi R^3 \times \text{density } (\rho)]$$

$$\therefore g = \frac{4}{3} \pi \rho GR$$

Notes:

- From the expression $g = \frac{GM}{R^2} = \frac{4}{3} \pi \rho GR$ it is clear that its value depends upon the mass, radius and density of planet and it is independent of mass, shape and density of the body placed on the surface of the planet. i.e. a given planet (reference body) produces same acceleration in a light as well as heavy body.
- The greater the value of (M/R^2) or ρR , greater will be the value of g for that planet.

- Acceleration due to gravity is a vector quantity and its direction is always towards the centre of the planet.
- Dimensions of $[g] = [LT^{-2}]$
- Average value of g is taken as 9.8 m/s^2 or 981 cm/s^2 , on the surface of the earth at mean sea level.
- In general, the value of acceleration due to gravity vary due to the following factors: (a) Shape of the earth, (b) Height above the earth surface, (c) Depth below the earth surface and (d) Axial rotation of the earth.

EXAMPLE 8.3:

Acceleration due to gravity on moon is $(1/6)^{\text{th}}$ of the acceleration due to gravity on earth. If the ratio of densities of earth (ρ_e) and moon (ρ_m) is

$$\frac{\rho_e}{\rho_m} = \frac{5}{3}, \text{ find the radius of moon } R_m \text{ in terms of radius of the earth } R_e.$$

Solution:

$$\text{Acceleration due to gravity, } g = \frac{4}{3}\pi\rho GR \quad \therefore g \propto R$$

$$\text{or} \quad \frac{g_m}{g_e} = \frac{\rho_m}{\rho_e} = \frac{R_m}{R_e} \quad \left[\text{As } \frac{g_m}{g_e} = \frac{1}{6} \text{ and } \left(\frac{\rho_e}{\rho_m} = \frac{5}{3} \right) \text{ (given)} \right]$$

\therefore

$$\frac{R_e}{R_m} = \left(\frac{g_e}{g_m} \right) \left(\frac{\rho_e}{\rho_m} \right) = \frac{1}{6} \times \frac{5}{3} \quad \therefore R_m = \frac{5}{18} R_e$$

EXAMPLE 8.4:

The moon's radius is $(1/4)^{\text{th}}$ of that of earth and its mass is $1/80$ times that of the earth. If g represents the acceleration due to gravity on the surface of the earth, what is acceleration due to gravity on the surface of the moon?

Solution:

$$\text{Acceleration due to gravity, } g = \frac{GM}{R^2}$$

$$\frac{g_{\text{moon}}}{g_{\text{earth}}} = \frac{M_{\text{moon}}}{M_{\text{earth}}} \times \frac{R_{\text{earth}}^2}{R_{\text{moon}}^2} = \left(\frac{1}{80} \right) \left(\frac{4}{1} \right)^2$$

$$\frac{g'}{g} = \left(\frac{R}{R+h} \right)^2 = \left(\frac{R}{R+2R} \right)^2 = \frac{1}{9} \quad \Rightarrow g' = \frac{g}{9}$$

$$g_{\text{moon}} = g_{\text{earth}} \times \frac{16}{80} = \frac{g}{5}.$$

8.6. VARIATION OF ACCELERATION DUE TO GRAVITY WITH HEIGHT

Consider a particle placed at a height h above the surface of the earth where acceleration due to gravity is g' as shown on the figure below.

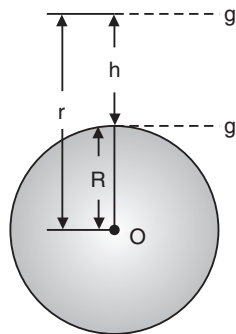

Fig. 8.8: Variation of acceleration due to gravity with height

Acceleration due to gravity at the surface of the earth

$$g = \frac{GM}{R^2} \quad \text{..... Equation 8-8}$$

Acceleration due to gravity at height h from the surface of the earth

$$g' = \frac{GM}{(R+h)^2} \quad \text{..... Equation 8-9}$$

From equations 8-8 and 8-9:

$$g' = g \left(\frac{R}{R+h} \right)^2 \quad \text{..... Equation 8-10}$$

$$\square \quad r = R + h$$

$$\therefore \quad g' = g \frac{R^2}{r^2}$$

Notes:

- As we go above the surface of the earth, the value of g decreases because $g' \propto \frac{1}{r^2}$.

This expression can be plotted on the graph as:

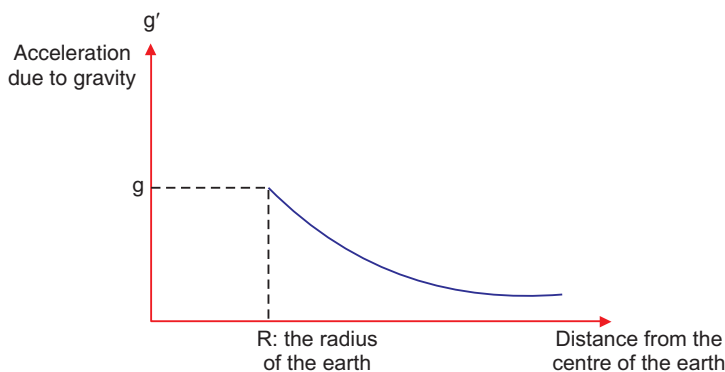

Fig. 8.9: Curve of variation of acceleration due to gravity with height.

- If $r = \infty$ then $g' = 0$, i.e. at infinite distance from the earth, the value of g becomes zero.
- If $h \ll R$, i.e. height is negligible in comparison to the radius. Then from equation (iii), we get

$$g' = g \left(\frac{R}{R+h} \right)^2 = g \left(1 + \frac{h}{R} \right)^{-1} = g \left[1 - \frac{2h}{R} \right] \quad [\text{As } h \ll R]$$

- If $h \ll R$, then decrease in the value of g with height:

Absolute decrease, $\Delta g = g - g' = \frac{2hg}{R}$

Fractional decrease, $\frac{\Delta g}{g} = \frac{g - g'}{g} = \frac{2h}{R}$

Percentage decrease, $\frac{\Delta g}{g} \times 100\% = \frac{2h}{R} \times 100\%$

EXAMPLE 8.5:

The acceleration of a body due to the attraction of the earth (radius R) is g . Find the acceleration due to gravity at a distance $2R$ from the surface of the earth.

Solution:

$$\frac{g'}{g} \left(\frac{R}{R+h} \right)^2 = \left(\frac{R}{R+2R} \right)^2 = \frac{1}{9} \Rightarrow g' = \frac{g}{9}$$

EXAMPLE 8.6:

Find the height of the point above the earth's surface, at which acceleration due to gravity becomes 1% of its value at the surface is (Radius of the earth = R).

$$g' = g \left(\frac{R}{R+h} \right)^2$$

Solution:

Acceleration due to gravity at height h is given by

$$\Rightarrow \frac{g}{100} = g \left(\frac{R}{R+h} \right)^2 \Rightarrow \frac{R}{R+h} = \frac{1}{10} \Rightarrow h = 9R$$

8.7. VARIATION OF GRAVITY WITH DEPTH

Consider a mass placed at point P below the surface of the earth as shown below:

Acceleration due to gravity at the surface of the earth

$$g = \frac{GM}{R^2} = \frac{4}{3} \pi \rho GR \quad \dots\dots\dots \text{Equation 8-11}$$

Acceleration due to gravity at depth d from the surface of the earth of radius R

$$g' = \frac{4}{3} \pi \rho G(R-d) \quad \dots\dots\dots \text{Equation 8-12}$$

Dividing equations 8-12 by 8-11, we get

$$g' = g \left| 1 - \frac{d}{R} \right|$$

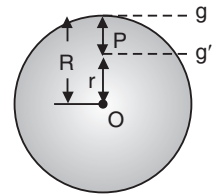

Fig. 8.10

Notes:

- The value of g decreases on going below the surface of the earth. From equation 8-12, we get $g' \propto (R - d)$. So it is clear that if d increases, the value of g decreases.

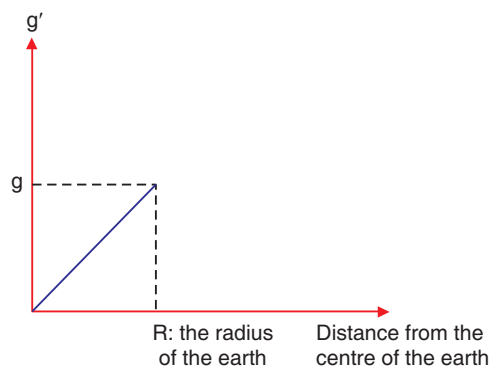

Fig. 8.11: Variation of gravity with depth

Combining the graphs for variation of acceleration due to gravity below and above the surface of the earth will give the graph as shown below:

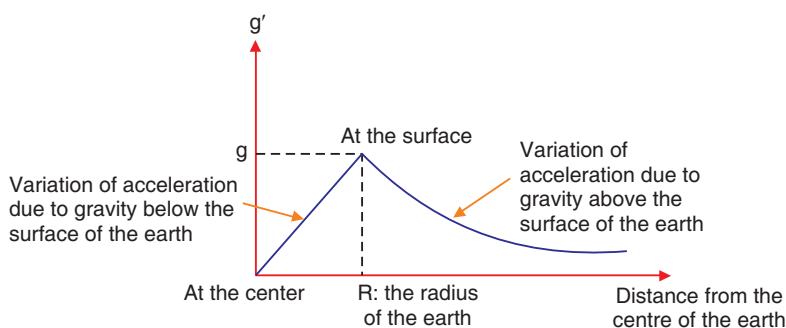

Fig. 8.12: Curve of Variation of gravity with depth and height

- At the centre of earth $d = R \therefore g' = 0$, i.e., the acceleration due to gravity at the centre of earth becomes zero.

- Decrease in the value of g with depth

Absolute decrease,
$$\Delta g = g - g' = \frac{dg}{R}$$

Fractional decrease,
$$\frac{\Delta g}{g} = \frac{g - g'}{g} = \frac{d}{R}$$

Percentage decrease,
$$\frac{\Delta g}{g} \times 100\% = \frac{d}{R} \times 100\%$$

- The rate of decrease of gravity outside the earth ($h \ll R$) is double to that of inside the earth.

EXAMPLE 8.7:

Weight of a body of mass m decreases by 1% when it is raised to height h above the earth's surface. If the body is taken to a depth h in a mine, what is the change in its weight?

Solution:

Percentage change in g when the body is raised to height h ,

$$\frac{\Delta g}{g} \times 100\% = \frac{2h \times 100}{R} = 1\%$$

Percentage change in g when the body is taken into depth d ,

$$\frac{\Delta g}{g} \times 100\% = \frac{d}{R} \times 100\% = \frac{h}{R} \times 100\% \quad [\text{As } d = h]$$

Percentage decrease in weight =

$$\frac{1}{2} \left(\frac{2h}{R} \times 100 \right) = \frac{1}{2} (1\%) = 0.5\%$$

EXAMPLE 8.8:

What is the depth at which the effective value of acceleration due to gravity

is $\frac{g}{4}$? (R = radius of the earth)

Solution:

$$g' = g \left(1 - \frac{d}{R} \right) \Rightarrow \frac{g}{4} = g \left(1 - \frac{d}{R} \right) \Rightarrow d = \frac{3R}{4}$$

8.8. VARIATION IN G DUE TO ROTATION OF EARTH

As the earth rotates, a body placed on its surface moves along the circular path and hence experiences centrifugal force. Due to it, the apparent weight of the body decreases.

Since the magnitude of centrifugal force varies with the latitude of the place, therefore the apparent weight of the body varies with latitude due to variation in the magnitude of centrifugal force on the body.

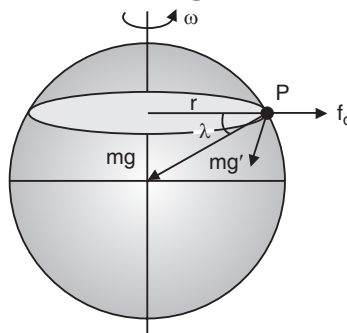

Fig. 8.13: Variation in g due to rotation of earth.

If the body of mass m lying at point P , whose latitude is λ , then due to rotation of earth its apparent weight can be given by the vector sum of the weight of the body and centripetal force

$$m\vec{g}' = m\vec{g} + \vec{F}_c$$

or $mg' = \sqrt{(mg)^2 + (F_c)^2 + 2mg F_c \cos(180^\circ - \lambda)}$

$\Rightarrow mg' = \sqrt{(mg)^2 + (m\omega^2 R \cos \lambda)^2 + 2mg m\omega^2 R \cos \lambda (-\cos \lambda)}$

[As $F_c = m\omega^2 r = m\omega^2 R \cos \lambda$] Equation 8-13

By solving we get, $g' = g - \omega^2 R \cos^2 \lambda$ Equation 8-14

The latitude at a point on the surface of the earth is defined as the angle, which the line joining that points to the centre of earth makes with equatorial plane. It is denoted by λ . For the poles, $\lambda = 90^\circ$ and for equator, $\lambda = 0^\circ$.

Notes:

- Substituting $\lambda = 90^\circ$ in the above expression, we get

$$g_{\text{pole}} = g - \omega^2 R \cos^2 90^\circ.$$

$\therefore g_{\text{pole}} = g$ Equation 8-15

i.e., there is no effect of rotational motion of the earth on the value of g at the poles.

- Substituting $\lambda = 0^\circ$ in the above expression, we get $g_{\text{equator}} = 0^\circ$.

$\therefore g_{\text{equator}} = g - \omega^2 R$ Equation 8-16

i.e., the effect of rotation of earth on the value of g at the equator is maximum.

From the equations 8-15 and 8-16

$$g_{\text{pole}} - g_{\text{equator}} = R\omega^2 = 0.034 \text{ m/s}^2 \quad \text{..... Equation 8-17}$$

- When a body of mass m is moved from the equator to the poles, its weight increases by an amount

$$m(g_p - g_e) = m\omega^2 R \quad \text{..... Equation 8-18}$$

- Weightlessness due to rotation of earth: As we know that apparent weight of the body decreases due to rotation of earth. If ω is the angular velocity of rotation of earth for which a body at the equator will become weightless.

$$g' = g - \omega^2 R \cos^2 \lambda$$

$\Rightarrow 0 = g - \omega^2 R \cos^2 0^\circ$ [As $\lambda = 0$ for equator]

$$\Rightarrow g = \omega^2 R \quad \therefore \omega = \sqrt{\frac{g}{R}}$$

$$\text{or time period of rotation of earth, } T = \frac{2\pi}{\omega} = 2\pi \sqrt{\frac{R}{g}}$$

Substituting the value of $R = 6400 \times 10^3 \text{ m}$ and $g = 10 \text{ m/s}^2$, we get

$$\omega = \frac{1}{800} = 1.25 \times 10^{-3} \frac{\text{rad}}{\text{s}}$$

$$\text{and } T = 5026.5 \text{ s} = 1.40 \text{ h.}$$

- This time is about $\frac{1}{17}$ times the present time period of rotation of earth. Therefore, if the earth starts rotating 17 times faster than all objects on equator will become weightless.
- If earth stops rotating about its own axis, then, at the equator, the value of g increases by $\omega^2 R$ and consequently the weight of body lying there increases by $m\omega^2 R$.
- **Work done in planetary motion** by gravity of sun is zero. This is because force acting on the planet is towards the centre of sun while the direction of displacement is tangentially forward. Since the two are perpendicular, work done $= \vec{f} \cdot \vec{d} = Fd \cos \theta$ becomes zero. This is because, $\theta = 90^\circ \Rightarrow \cos 90^\circ = 0$.

EXAMPLE 8.9:

What is the angular velocity of the earth with which it has to rotate so that acceleration due to gravity on 60° latitude becomes zero? (Radius of earth = 6400 km. At the poles $g = 10 \text{ ms}^{-2}$)

Solution:

Effective acceleration due to gravity due to rotation of earth,

$$g' = g - \omega^2 R \cos^2 \lambda$$

$$\Rightarrow 0 = g - \omega^2 R \cos^2 60^\circ \Rightarrow \frac{\omega^2 R}{4} = g$$

$$\Rightarrow \omega = \sqrt{\frac{4g}{R}} = 2\sqrt{\frac{g}{R}} = 2\sqrt{\frac{10}{6400}} \quad [\text{As } g' = 0 \text{ and } \lambda = 60^\circ]$$

$$\Rightarrow \omega = 7.9 \times 10^{-2} \text{ rad/s}$$

8.9. VARIATION OF 'G' DUE TO SHAPE OF EARTH

Earth is elliptical in shape. It is flattened at the poles and bulged out at the equator.

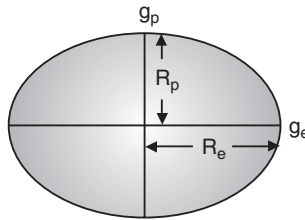

Fig. 8.14: Variation of g due to shape of earth.

The equatorial radius is about 21 km longer than polar radius.

$$\text{At equator, } g_e = \frac{GM}{R_e^2} \quad \text{..... Equation 8-19}$$

$$\text{At poles, } g_p = \frac{GM}{R_p^2} \quad \text{..... Equation 8-20}$$

From equations 8-19 and 8-20

$$\frac{g_e}{g_p} = \frac{R_p^2}{R_e^2}$$

Since $R_{\text{equator}} > R_{\text{pole}} \quad \therefore \quad g_{\text{pole}} > g_{\text{equator}} \quad \text{and } g_p = g_e + 0.018 \text{ ms}^{-2}$

Therefore, the weight of body increases as it is taken from equator to the pole.

8.10. ROCKETS

A rocket is a device that produces thrust by ejecting stored matter. A rocket moves forward when gas expelled from the rear of a rocket pushes it in the opposite direction. From Newton's laws of motion, for every action, there is an equal and opposite reaction. In a rocket, fuel is burned to make a hot gas and this hot gas is forced out of narrow nozzles in the back of the rocket, propelling the rocket forward.

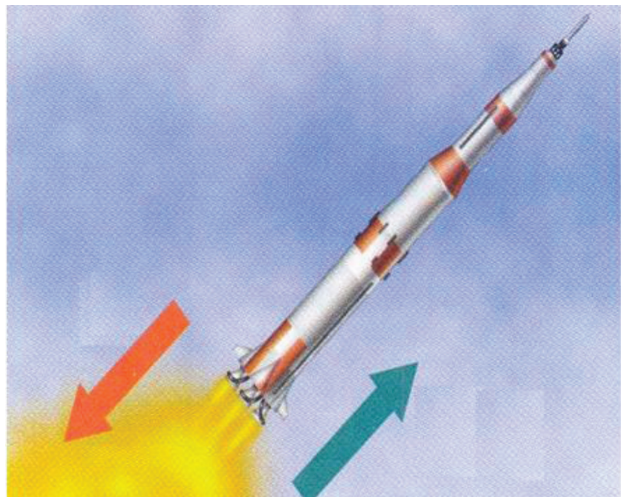

Fig. 8.15: Rocket

Spacecraft Propulsion

Spacecraft Propulsion is characterized in general by its complete integration within the spacecraft (e.g. satellites). Its function is to provide forces and torques in (empty) space to:

- transfer the spacecraft: used for interplanetary travel
- position the spacecraft: used for orbit control
- orient the spacecraft: used for altitude control



Fig. 8.16: Spacecraft

The jet propulsion systems for launching rockets are also called primary propulsion systems. Spacecrafts, e.g. satellites, are operated by secondary propulsion systems.

Characteristics of Spacecraft Propulsion Systems

In order to fulfill altitude and orbit operational requirements of spacecraft, spacecraft propulsion systems are characterized by:

- Very high velocity increment capability (many km/s)
- Low thrust levels (1 mN to 500 N) with low acceleration levels
- Continuous operation mode for orbit control
- Pulsed operation mode for altitude control
- Predictable, accurate and repeatable performance (impulse bits)
- Reliable, leak-free long time operation (storable propellants)
- Minimum and predictable thrust exhaust impingement effects

Classification of Propulsion Systems

Spacecraft propulsion can be classified according to the source of energy utilized for the ejection of propellant:

- **Chemical propulsion** use heat energy produced by a chemical reaction to generate gases at high temperature and pressure in a combustion chamber. These hot gases are accelerated through a nozzle and ejected from the system at a high exit velocity to produce thrust force.
- **Electric propulsion** uses electric or electromagnetic energy to eject matter at high velocity to produce thrust force.
- **Nuclear propulsion** uses energy from a nuclear reactor to heat gases which are then accelerated through a nozzle and ejected from the system at a high exit velocity to produce thrust force.

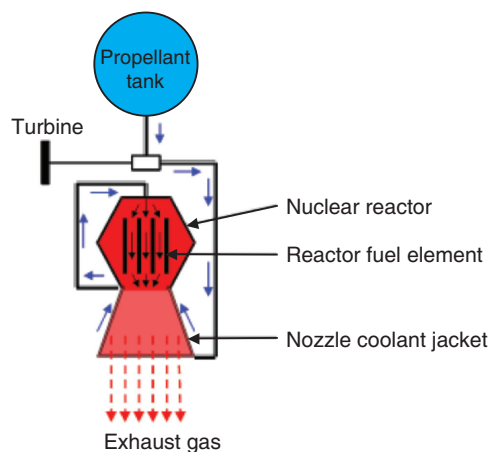

Fig. 8.17: Nuclear propulsion

Notes:

- While chemical and electric systems are used for the propulsion of today's spacecrafts, nuclear propulsion is still under study. Therefore, only chemical and electric propulsion will be dealt with in this book.

8.11. SATELLITES

A satellite is an artificial or a natural body placed in orbit round the earth or another planet in order to collect information or for communication. Communication satellites are satellites that are used specifically to communicate. Part of that communication will be the usual commands and signals we get from any satellite. The payload of the satellite consists of huge collection of powerful radio transmitters and a big dish or something like that, to enable it to talk to things on the ground. And we'll use them to transmit TV signals, to transmit radio signals, and in some cases, it might be to be transmit internet signals. So, all of that gets turned into radio somehow and transmitted up into space and then bounced back down somewhere else.

There is only one main force acting on a satellite when it is in orbit, and that is the gravitational force exerted on the satellite by the Earth. This force is constantly pulling the satellite towards the centre of the Earth.

A satellite doesn't fall straight down to the Earth because of its velocity. Throughout a satellite's orbit there is a perfect balance between the gravitational force due to the Earth, and the centripetal force necessary to maintain the orbit of the satellite.

8.11.1. Orbital Velocity of Satellite.

Satellites are natural or artificial bodies describing orbit around a planet under its gravitational attraction. Moon is a natural satellite while INSAT-1B is an artificial satellite of the earth. Condition for establishment of artificial satellite is that the centre of orbit of satellite must coincide with centre of earth or satellite must move around great circle of earth.

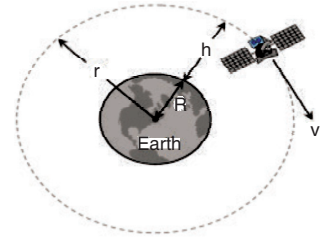

Fig. 8.18: Orbital Velocity of Satellite

Orbital velocity of a satellite is the velocity required to put the satellite into its orbit around the earth. For revolution of satellite around the earth, the gravitational pull provides the required centripetal force.

$$\frac{mv^2}{r} = \frac{GMm}{r^2}$$

$$\Rightarrow v = \sqrt{\frac{GM}{r}} \quad \dots\dots\dots \text{Equation 8-21}$$

$$v = \sqrt{\frac{gR^2}{R+h}} = R\sqrt{\frac{g}{R+h}} \quad \dots\dots\dots \text{Equation 8-22}$$

$$[\text{As } GM = gR^2 \quad \text{and} \quad r = R + h] \quad \dots\dots\dots \text{Equation 8-23}$$

Notes:

- Orbital velocity is independent of the mass of the orbiting body and is always along the tangent of the orbit, i.e. satellites of different masses have the same orbital velocity, if they are in the same orbit.
- Orbital velocity depends on the mass of central body and radius of orbit.
- For a given planet, greater the radius of orbit, lesser will be the orbital velocity of the satellite ($v \propto 1/\sqrt{r}$).
- Orbital velocity of the satellite when it revolves very close to the surface of the planet:

$$v = \sqrt{\frac{GM}{r}} = \sqrt{\frac{GM}{R+h}}$$

$$\therefore v = \sqrt{\frac{GM}{R}} = \sqrt{gR} \quad [\text{As } h = 0 \text{ and } GM = gR^2]$$

For the earth $v = \sqrt{9.8 \times 6.4 \times 10^6} = 7.9 \text{ km/s} \approx 8 \text{ km/s} \Rightarrow 2^{\text{nd}}$ cosmic velocity

- Close to the surface of planet, $v = \sqrt{\frac{GM}{R}} \quad [\text{As } v_e = \sqrt{\frac{2GM}{R}}]$

$$\therefore v = \frac{v_e}{\sqrt{2}}, \text{ i.e. } v_{\text{escape}} = \sqrt{2} v_{\text{orbital}} \quad \dots\dots\dots \text{Equation 8-24}$$

It means that if the speed of a satellite orbiting close to the earth is made $\sqrt{2}$ times (or increased by 41%) then it will escape from the gravitational field.

- If the gravitational force of attraction of the sun on the planet varies as $F \propto \frac{1}{r^n}$, then the orbital velocity varies as:

$$v \propto \frac{1}{\sqrt{r^n - 1}} \quad \dots\dots\dots \text{Equation 8-25}$$

EXAMPLE 8.10:

Two satellites *A* and *B* go round a planet *P* in circular orbits having radii $4R$ and R respectively. If the speed of the satellite *A* is $3v$, what is the speed of the satellite *B*?

Solution:

Orbital velocity of satellite

$$v = \sqrt{\frac{GM}{r}} \quad \therefore v = \frac{1}{\sqrt{r}} \Rightarrow \frac{v_B}{v_A} = \sqrt{\frac{r_A}{r_B}}$$

$$\Rightarrow \frac{v_B}{3v} = \sqrt{\frac{4R}{R}} \Rightarrow v_B = 6v.$$

EXAMPLE 8.11:

A satellite is moving around the earth with speed v in a circular orbit of radius r . If the orbit radius is decreased by 1%, what is its speed?

Solution:

Orbital velocity, $v = \sqrt{\frac{Gm}{r}}$

$$\therefore v \propto \frac{1}{\sqrt{r}} \quad [\text{If } r \text{ decreases, then } v \text{ increases}]$$

Percentage change in $v = \frac{1}{2}$ (percentage change in r) = $\frac{1}{2}$ (1%) = 0.5%

∴ Orbital velocity increases by 0.5%.

8.11.2. Time Period of Satellite

It is the time taken by satellite to go once around the earth.

$$\therefore T = \frac{\text{circumference of the orbit}}{\text{orbit velocity}}$$

$$\Rightarrow T = \frac{2\pi r}{v} = 2\pi r \sqrt{\frac{r}{GM}} \quad [\text{As } v = \sqrt{\frac{GM}{r}}]$$

$$\Rightarrow T = 2\pi \sqrt{\frac{r^3}{GM}} = 2\pi \sqrt{\frac{(R+h)^3}{gR^2}} \quad [\text{As } GM = gR^2]$$

$$\Rightarrow T = 2\pi \sqrt{\frac{(R+h)^3}{gR^2}} = 2\pi \sqrt{\frac{R}{g} \left(1 + \frac{h}{R}\right)^{3/2}}$$

Notes:

- From $T = 2\pi \sqrt{\frac{r^3}{GM}}$, it is clear that time period is independent of the mass of orbiting body and depends on the mass of central body and radius of the orbit.

$$\bullet T = 2\pi \sqrt{\frac{r^3}{GM}}$$

$$\Rightarrow T^2 = \frac{4\pi^2}{GM} r^3 \quad \text{i.e. } T^2 \propto r^3$$

This is in accordance with Kepler's third law of planetary motion.

- Time period of nearby satellite,

$$\text{From } T = 2\pi \sqrt{\frac{r^3}{GM}} = 2\pi \sqrt{\frac{R^3}{gR^2}} = 2\pi \sqrt{\frac{R}{g}} \quad \dots\dots\dots \text{Equation 8-26}$$

[As $h = 0$ and $GM = gR^2$]

For earth $R = 6400$ km and $g = 9.8$ m/s²

$$\Rightarrow T = 84.6 \text{ minute} \approx 1.4 \text{ h.}$$

- Time period of nearby satellite in terms of density of planet can be given as

$$T = 2\pi \sqrt{\frac{r^3}{GM}} = 2\pi \sqrt{\frac{R^3}{GM}} = \frac{2\pi(R^3)^{1/2}}{\left[G \cdot \frac{4}{3} \pi R^3 \rho\right]^{1/2}}$$

$$T = \sqrt{\frac{3\pi}{G\rho}} \quad \text{..... Equation 8-27}$$

- If the gravitational force of attraction of the sun on the planet varies as $F \propto \frac{1}{r^n}$, then the time period varies as $T \propto r^{\frac{n+1}{2}}$.
- If there is a satellite in the equatorial plane rotating in the direction of earth's rotation from west to east, then for an observer, on the earth, angular velocity of satellite will be $(\omega_S - \omega_E)$. The time interval between the two consecutive appearances overhead will be

$$T = \frac{2\pi}{\omega_S - \omega_E} = \frac{T_S T_E}{T_E - T_S} \quad \text{..... Equation 8-28}$$

$$\left[\text{As } T = \frac{2\pi}{\omega} \right]$$

If $\omega_S = \omega_E$, $T = \infty$ i.e. satellite will appear stationary relative to earth. Such satellites are called geostationary satellites.

EXAMPLE 8.12:

A satellite is launched into a circular orbit of radius ' R ' around earth while a second satellite is launched into an orbit of radius $1.02 R$. What is the percentage difference in the time periods of the two satellites?

Solution:

Orbital radius of second satellite is 2% more than the first satellite.

So from $T \propto (r)^{3/2}$, percentage increase in time period = $\frac{3}{2}$ (Percentage increase in orbital radius)

$$= \frac{3}{2} (2\%) = 3\%.$$

EXAMPLE 8.13:

What is the periodic time of a satellite revolving above Earth's surface at a height equal to R , where R is the radius of Earth?

Solution:

$$\begin{aligned} T &= 2\pi \sqrt{\frac{(R+h)^3}{GM}} = 2\pi \sqrt{\frac{(R+R)^3}{gR^2}} \\ &= 2\pi \sqrt{\frac{8R}{g}} = 4\sqrt{2}\pi \sqrt{\frac{R}{g}} \quad [\text{As } h = R \text{ (given)}]. \end{aligned}$$

8.11.3. Height of Satellite

As we know, time period of satellite $T = 2\pi \sqrt{\frac{r^3}{GM}} = 2\pi \sqrt{\frac{(R+h)^3}{gR^2}}$

By squaring and rearranging both sides, $\frac{gR^2 T^2}{4\pi^2} = (R+h)^3$

$$\Rightarrow h = \left(\frac{T^2 g R^2}{4\pi^2} \right)^{1/3} - R \quad \dots\dots\dots \text{Equation 8-29}$$

By knowing the value of time period we can calculate the height of satellite the surface of the earth.

EXAMPLE 8.14:

Given radius of earth ' R ' and length of a day ' T ', what is the height of a geostationary satellite?

Solution:

$$h = \left(\frac{T^2 g R^2}{4\pi^2} \right)^{1/3} - R$$

From the expression

$$\therefore h = \left(\frac{GMT^2}{4\pi^2} \right)^{1/3} - R \quad [\text{As } gR^2 = GM]$$

EXAMPLE 8.15:

A satellite is revolving round the earth in circular orbit at some height above surface of the earth. It takes 5.26×10^3 seconds to complete a revolution while its centripetal acceleration is 9.32 m/s^2 . What is the height of satellite above the surface of earth? (Radius of the earth $6.37 \times 10^6 \text{ m}$)

Solution:

Centripetal acceleration (a_c) = $\frac{v^2}{r}$ and $T = \frac{2\pi r}{v}$

From equations (i) and (ii) $r = \frac{a_c T^2}{4\pi^2} \Rightarrow R + h = \frac{9.32 \times (5.26 \times 10^3)^2}{4 \times \pi^2}$

$h = 6.53 \times 10^6 - R = 6.53 \times 10^6 - 6.37 \times 10^6 = 160 \times 10^3 \text{ m} = 160 \text{ km} \approx 170 \text{ km}$.

8.11.4. Geostationary Satellite

The satellite which appears stationary relative to earth is called geostationary or geosynchronous satellite, e.g. communication satellite.

A geostationary satellite always stays over the same place above the earth. Such a satellite is never at rest. It appears stationary due to its zero relative velocity with respect to that place on earth.

The orbit of a geostationary satellite is known as the parking orbit.

Notes:

- It should revolve in an orbit concentric and coplanar with the equatorial plane.
- Its sense of rotation should be same as that of earth about its own axis, i.e. in anti-clockwise direction (from west to east).
- Its period of revolution around the earth should be the same as that of earth about its own axis.

$$\therefore T = 24 \text{ h} = 86400 \text{ s}$$

- Height of geostationary satellite

$$\text{As } T = 2\pi\sqrt{\frac{r^3}{GM}} \Rightarrow 2\pi\sqrt{\frac{(R+h)^3}{GM}} = 24 \text{ h}$$

Substituting the value of G and M we get $R + h = r = 42000 \text{ km} = 7R$

\therefore Height of geostationary satellite from the surface of earth,

$$h = 6R = 36000 \text{ km}$$

- Orbital velocity of geostationary satellite can be calculated by

$$v = \sqrt{\frac{GM}{r}}$$

- Substituting the value of G and M , we get $v = 3.08 \text{ km/s}$.

8.11.5. Energy of Satellite

When a satellite revolves around a planet in its orbit, it possesses both potential energy (due to its position against gravitational pull of earth) and kinetic energy (due to orbital motion).

1. Potential energy: $U = mV = -\frac{GMm}{r}$ $\left[AsV = -\frac{GM}{r}, L^2 = m^2GMr \right]$
2. Kinetic energy: $K = \frac{1}{2}mv^2 = \frac{GMm}{2r} = \frac{L^2}{2mr^2}$ $\left[Asv = \sqrt{\frac{GM}{r}} \right]$
3. Total energy: $E = U + K = \frac{-GMm}{r} + \frac{GMm}{2r} = \frac{-GMm}{2r} = \frac{-L^2}{2mr^2}$

Notes

- Kinetic energy, potential energy or total energy of a satellite depends on the mass of the satellite and the central body and also on the radius of the orbit.
- From the above expressions we can say that
Kinetic energy (K) = – (Total energy)
Potential energy (U) = 2 (Total energy)
Potential energy (K) = – 2 (Kinetic energy)

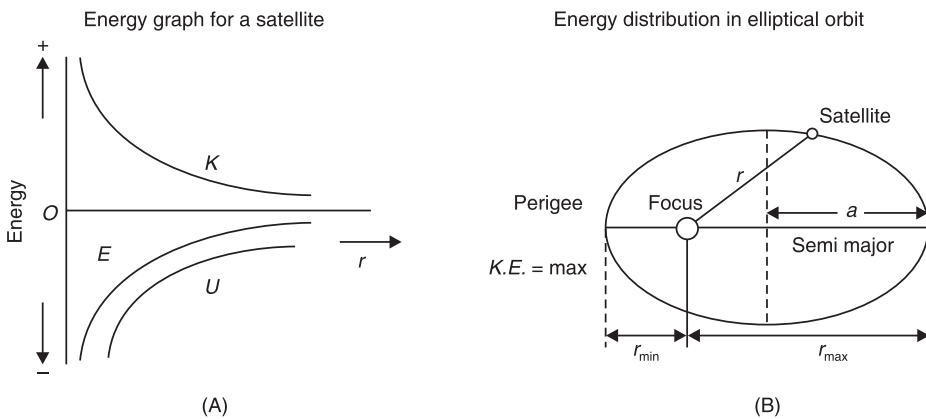

Fig. 8.19: Energy of a satellite.

- If the orbit of a satellite is elliptical, then
 - (a) Total energy (E) = $\frac{-GMm}{2a}$ = constant; where a is semi-major axis.
 - (b) Kinetic energy (K) will be maximum when the satellite is closest to the central body (at perigee) and minimum when it is farthest from the central body (at apogee).
 - (c) Potential energy (U) will be minimum when kinetic energy is maximum, i.e. when satellite is closest to the central body (at perigee). Potential energy is maximum when kinetic energy is minimum, i.e. the satellite is farthest from the central body (at apogee).

- **Binding Energy:** Total energy of a satellite in its orbit is negative. Negative energy means that the satellite is bound to the central body by an attractive force and energy must be supplied to remove it from the orbit to infinity. The energy required to remove the satellite from its orbit to infinity is called **Binding Energy** of the system, i.e.

$$\text{Binding Energy (B.E.)} = -E = \frac{GMm}{2r} \quad \text{..... Equation 8-33}$$

EXAMPLE 8.17:

What is the Potential energy of a satellite having mass ' m ' and rotating at a height of $6.4 \times 10^6 \text{ m}$ from the earth's centre?

Solution:

$$\text{Potential energy} = -\frac{GMm}{r} = -\frac{GMm}{R_e + h} = -\frac{GMm}{2R_e} \quad [\text{As } h = R_e \text{ (given)}]$$

$$\therefore \text{Potential energy} = -\frac{gR_e^2 m}{2R_e} = -0.5 mgR_e \quad [\text{As } GM = gR_e^2]$$

EXAMPLE 8.18:

Two satellites are moving around the earth in circular orbits at height R and $3R$ respectively, R being the radius of the earth. What is the ratio of their kinetic energies?

Solution:

$$r_1 = R + h_1 = R + R = 2R \text{ and}$$

$$r_2 = R + h_2 = R + 3R = 4R$$

$$\text{Kinetic energy} \propto \frac{1}{r} \quad \therefore \frac{(KE)_1}{(KE)_2} = \frac{r_2}{r_1} = \frac{4R}{2R} = \frac{2}{1} = 2$$

Application Activity 8.2

1. The distance of Neptune and Saturn from sun are nearly 10^{13} and 10^{12} metres respectively. Assuming that they move in circular orbits, what will be their periodic times in the ratio?
2. A spherical planet far out in space has a mass M_0 and diameter D_0 . A particle of mass m falling freely near the surface of this planet will experience an acceleration due to gravity which is equal to g . Derive the expression of g in terms of D .
3. At surface of earth, weight of a person is 72 N . What is his weight at height $R/2$ from surface of earth ($R =$ radius of earth)?
4. Assuming earth to be a sphere of a uniform density, what is the value of gravitational acceleration in a mine 100 km below the earth's surface (Given $R = 6400\text{ km}$)?
5. If the gravitational force between two objects was proportional to $1/R$; where R is separation between them, then a particle in circular orbit under such a force would have its orbital speed v proportional to which value?
6. An earth satellite S has an orbital radius which is 4 times that of a communication satellite C . What is its period of revolution?

8.12 TYPES AND APPLICATIONS OF SATELLITE SYSTEMS

Four different types of satellite orbits have been identified depending on the shape and diameter of each orbit:

- GEO (Geo-stationary earth orbit)
- MEO (medium earth orbit)
- LEO (Low earth orbit) and
- HEO (Highly elliptical orbit)

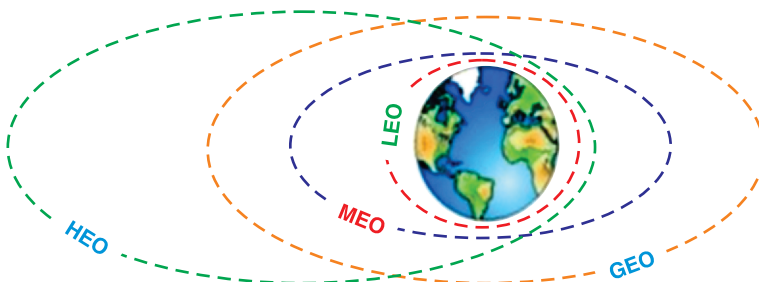

Fig. 8.20: Types of satellite orbits

GEO (geostationary orbit)

A geostationary orbit or geosynchronous equatorial orbit (GEO) has a circular orbit 35,786 kilometres above the Earth's equator and following the direction of the Earth's rotation. An object in such an orbit has an orbital period equal to the Earth's rotational period (one sidereal day) and thus appears motionless, at a fixed position in the sky, to ground observers.

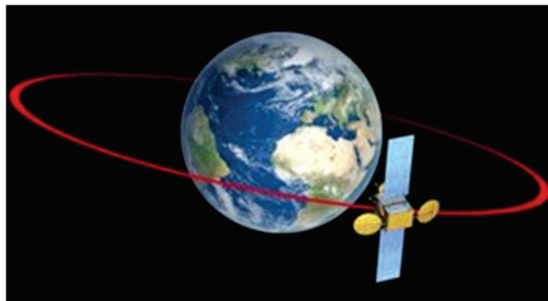

Fig. 8.21: Geostationary orbit

Most common geostationary satellites are either weather satellites or communication satellites relaying signals between two or more ground stations and satellites that broadcast signals to a large area on the planet. All radio and TV, whether satellite etc. are launched in this orbit.

Advantages of Geo-Stationary Earth Orbit

1. It is possible to cover almost all parts of the earth with just 3 geo satellites.
2. Antennas need not be adjusted every now and then, but can be fixed permanently.
3. The life-time of a GEO satellite is quite high usually around 15 years.

Disadvantages of Geo-Stationary Earth Orbit

1. Larger antennas are required for northern/southern regions of the earth.
2. High buildings in a city limit the transmission quality.
3. High transmission power is required.
4. These satellites cannot be used for small mobile phones.
5. Fixing a satellite at Geo stationary orbit is very expensive.

LEO (Low Earth Orbit)

Satellites in low Earth orbits are normally military reconnaissance satellites that can locate out tanks from 160 km above the Earth. They orbit the earth very quickly, one complete orbit normally taking 90 minutes. However, these orbits have very short lifetimes in the order of weeks compared with decades for geostationary satellites. Simple launch vehicles can be used to

place these satellites of large masses into orbit.

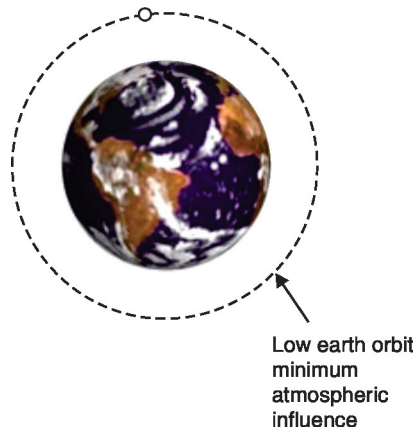

Fig. 8.22: Low Earth Orbit

Low Earth Orbit is used for things that we want to visit often with the Space Shuttle, like the Hubble Space Telescope and the International Space Station. This is convenient for installing new instruments, fixing things that are broken, and inspecting damage. It is also about the only way we can have people go up, do experiments, and return in a relatively short time.

A special type of LEO is the Polar Orbit. This is a LEO with a high inclination angle (close to 90 degrees). This means the satellite travels over the poles.



Polar orbit

Fig. 8.23: Polar Orbit

Advantages of Low Earth Orbit

1. The antennas can have low transmission power of about 1 watt.
2. The delay of packets is relatively low.
3. Useful for smaller foot prints

Disadvantages of Low Earth Orbit

1. If global coverage is required, it requires at least 50-200 satellites in this orbit.
2. Special handover mechanisms are required.
3. These satellites involve complex design.
4. Very short life: Time of 5-8 years. Assuming 48 satellites with a life-time of 8 years each, a new satellite is needed every 2 months.

5. Data packets should be routed from satellite to satellite.

MEO (Medium Earth Orbit) or ICO (Intermediate Circular Orbit)

Medium Earth Orbit satellites move around the earth at a height of 6000-20000 km above earth's surface. Their signal takes 50 to 150 milliseconds to make the round trip. MEO satellites cover more earth area than LEOs but have a higher latency. MEOS are often used in conjunction with GEO satellite systems.

Advantages of Medium Earth Orbit

1. Compared to LEO system, MEO requires only a dozen satellites.
2. Simple in design.
3. Requires very few handovers.

Disadvantages of Medium Earth Orbit

1. Satellites require higher transmission power.
2. Special antennas are required.

HEO (Highly Elliptical Orbit)

A satellite in elliptical orbit follows an oval-shaped path. One part of the orbit is closest to the centre of Earth (perigee) and another part is farthest away (apogee). A satellite in this type of orbit generally has an inclination angle of 64 degrees and takes about 12 hours to circle the planet. This type of orbit covers regions of high latitude for a large fraction of its orbital period.

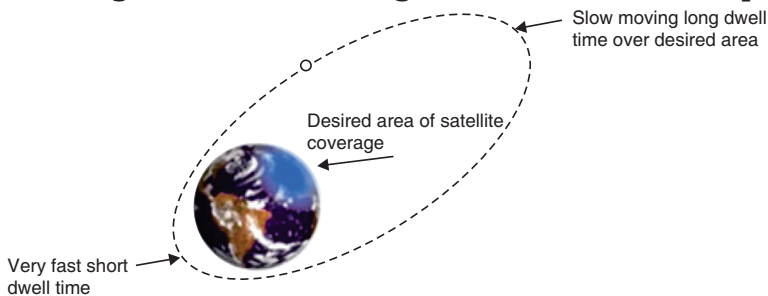

Fig. 8.24: Highly Elliptical Orbit

8.13. COSMIC VELOCITY FIRST, SECOND AND THIRD

The cosmic velocity is the initial velocity which a body must have to be able to overcome the gravity of another object.

We have:

1. The first cosmic velocity
2. Second cosmic velocity
3. The third cosmic velocity

8.13.1. The first cosmic velocity

As you know the satellites which were sent by a human are orbiting around the Earth. They had to be launched with a very high velocity, namely, with the first cosmic velocity.



Fig. 8.25: Orbiting satellite

This velocity can be calculated using the gravitational force and the centripetal force of the satellite:

$$\frac{mv_1^2}{R_e} = \frac{GM_e m}{R_e^2}$$

$$v_1 = \sqrt{\frac{GM_e}{R_e}} \quad \text{..... Equation 8-34}$$

Where:

v = the value of the first cosmic velocity

M_e = the mass of the Earth

R_e = the radius of the Earth

G = the gravitational constant

We put the data into this formula and we obtain:

$$v_1 = \sqrt{\frac{6.67 \times 10^{-11} \times 6.2 \times 10^{24}}{6.4 \times 10^6}} = 7900 \text{ m/s}$$

Satellites must have extremely high velocity to orbit around the Earth. In fact, satellites go around the Earth at the height $h = 160$ km in order not to break into the atmosphere.

8.13.2. Second cosmic velocity (escape velocity)

In the previous section we calculated the velocity which a body has to have to go around the Earth, which means that we calculated the value of the first cosmic velocity. Now it is time to give attention to calculating the second cosmic velocity *-it is the speed needed to “break free” from the gravitational attraction of the Earth or celestial body to which it is attract.*

In order to understand this issue we should know something about kinetic and potential energy.

$$\frac{1}{2} m v_e^2 = \frac{G M_e m}{R_e}$$

This value is calculated using the fact that as the body moves away from the Earth, the kinetic energy decreases and the potential energy increases. At infinity, both the energies are equal to zero, because, when the distance between the body and the Earth increases, the kinetic energy decreases and at infinity, it has the value of 0.

The potential energy at infinity has got the highest value but if we put infinity in the previous formula, we will obtain zero (or an extremely small fraction).

The value of the second cosmic velocity is calculated as follows;

$$\frac{1}{2} m v_e^2 = \frac{G M_e m}{R_e}$$
$$v_e = \sqrt{\frac{2 G M_e}{R_e}}$$
$$v_e = \sqrt{\frac{6.67 \times 10^{-11} \times 6.2 \times 10^{24}}{6.4 \times 10^6}} = 11200 \text{ m/s}$$

This called second cosmic velocity or escape velocity

And finally, the practical curiosity.

$$v_e = \sqrt{2} \times v_1 \quad \text{..... Equation 8-35}$$

We can also obtain the value of the second cosmic velocity by multiply the value of the first cosmic velocity by the square root of two.

8.13.3. The 3rd cosmic velocity

The third cosmic velocity is the initial velocity which a body has to have to leave the Solar System and its value is:

$$v_3 = 16.7 \text{ km/s at solar system}$$

At the surface of the Earth, this velocity is about 42 km/s. But due to its revolution, it is enough to launch the body with velocity 16.7 km/s in the direction of this movement.

8.13.4. The fourth cosmic velocity

It is the initial velocity which a body should have to leave the Milky Way.

$$v_e = \sqrt{\frac{2GM_G}{R_G}} \quad \begin{array}{l} \text{Whene } M_G = \text{man of milk way Galaxy} \\ R_G = \text{Radius of Galaxy} \end{array}$$

$$v_e = 130 \text{ km/s at milk way Galaxy}$$

This velocity is about 350 km/s but since Sun is going around the galaxy centre, so it is enough to launch the body with the velocity of 130 km/s in the direction of the Sun's movement.

Application Activity 8.3

The grid shown below contains terms used in this unit. Highlight at least 25 terms. Construct 10 sentences in context of motion in orbits using those words found in the grid.

	1	2	3	4	5	6	7	8	9	10	11	12	13	14	15	16
A	A	A	X	P	O	T	E	N	T	I	A	L	O	R	K	O
B	Q	C	V	I	Y	O	F	U	O	D	S	T	W	O	R	K
C	A	S	C	C	B	X	D	Y	O	H	X	L	I	T	A	I
D	S	A	O	E	Q	T	K	I	N	E	T	I	C	A	D	S
E	P	T	S	C	L	G	R	Y	O	I	L	W	I	T	I	V
F	S	E	M	Z	Y	E	N	E	R	G	Y	B	O	I	U	E
G	P	L	I	O	P	A	R	O	B	H	R	H	P	O	S	L
H	A	L	C	K	N	R	V	A	I	T	E	A	R	N	C	O
I	C	I	D	E	E	T	M	O	T	I	O	N	V	Q	X	C
J	E	T	Z	P	W	H	I	G	A	I	V	O	T	I	Y	I
L	C	E	I	L	T	O	B	O	L	F	O	R	C	E	T	T
M	R	S	G	E	O	S	T	A	T	I	O	N	A	R	Y	Y
N	A	X	M	R	N	X	Q	Z	O	R	O	C	K	E	T	S
O	F	I	W	R	O	P	R	O	P	U	L	S	I	O	N	O
P	T	P	L	A	N	E	T	A	R	Y	D	O	X	B	B	S

Application Activity 8.4

Using the Across and Down clues, write the correct words in the numbered grid below.

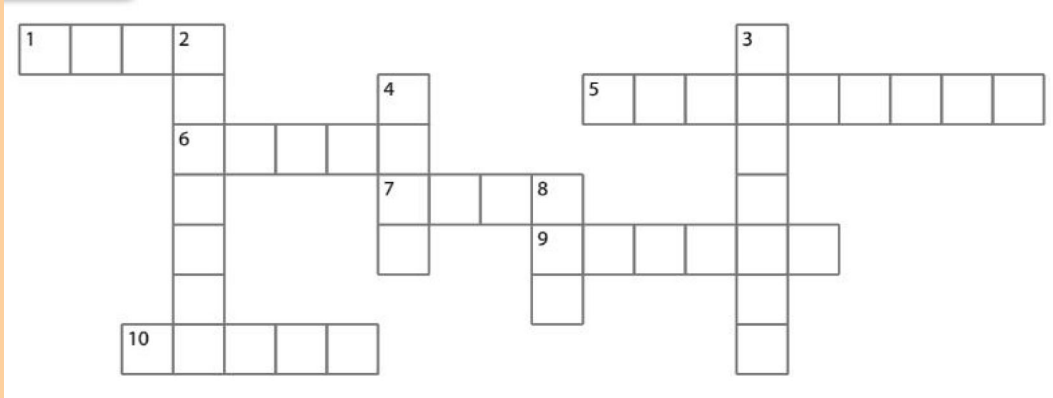

ACROSS

1. The only natural satellite of Earth.
5. An object in orbit around a planet.
6. The smallest planet and farthest from the Sun.
7. This planet probably got this name due to its red color and is sometimes referred to as the Red Planet.
9. This planet's blue color is the result of absorption of red light by methane in the upper atmosphere.
10. It is the brightest object in the sky except for the Sun and the Moon.

DOWN

2. Named after the Roman god of the sea.
3. The closest planet to the Sun and the eighth largest.
4. A large cloud of dust and gas which escapes from the nucleus of an active comet.
8. The largest object in the solar system.

END OF UNIT ASSESSMENT

1. A satellite **A** of mass m is at a distance of r from the centre of the earth. Another satellite **B** of mass $2m$ is at distance of $2r$ from the earth's centre. What is the ratio of their time periods?
2. Mass of moon is 7.34×10^{22} kg. If the acceleration due to gravity on the moon is 1.4 m/s^2 , find the radius of moon. Use ($G = 6.67 \times 10^{-11} \text{ Nm}^2/\text{kg}^2$).
3. A planet has mass $1/10$ of that of earth, while radius is $1/3$ that of earth. If a person can throw a stone on earth surface to a height of 90 m , to what height will he be able to throw the stone on that planet?
4. If the distance between centres of earth and moon is D and the mass of earth is 81 times the mass of moon, then at what distance from centre of earth the gravitational force will be zero?
5. What is the depth d at which the value of acceleration due to gravity becomes $\frac{1}{n}$ times the value at the surface? [R = radius of the earth]
6. The distance between centre of the earth and moon is 384000 km . If the mass of the earth is $6 \times 10^{24} \text{ kg}$ and $G = 6.67 \times 10^{-11} \text{ Nm}^2/\text{kg}^2$, what is the speed of the moon?
7. One project after deviation from its path, starts moving round the earth in a circular path at radius equal to nine times the radius at earth R , what is its time?
8. A satellite **A** of mass m is revolving round the earth at a height ' r ' from the centre. Another satellite **B** of mass $2m$ is revolving at a height $2r$. What is the ratio of their time periods?

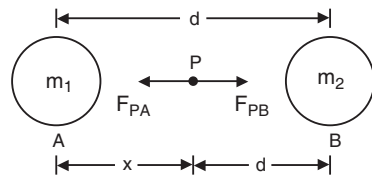

Fig. 8.26: Force between two masses

UNIT SUMMARY

Newton's law of gravitation

This is also called the universal law of gravitation or inverse square law. And states that “the gravitational force of attraction between two masses m_1 and m_2 is directly proportional to the product of masses and inversely proportional to the square of their mean distance apart.”

$$F = \frac{Gm_1m_2}{r^2}$$

Kepler's laws of planetary motion

1st Law: This law is called the law of orbits and states that planets move in ellipses with the sun as one of their foci. It can also be stated that planets describe ellipses about the sun as one focus.

2nd Law: This is called the law of areas and states that the line joining the sun and the planet sweeps out equal areas in equal periods of time.

3rd Law: The law of periods states that the square of the periods T of revolution of planets are proportional to the cubes of their mean distances R from the sun.

$$T^2 \propto R^3$$

Verification of Kepler's third law of planetary motion

Gravitational force of attraction of the sun and the planet

$$F_1 = \frac{Gm_1m_2}{R^2}$$

Centripetal force responsible for keeping the planet moving in a circular motion around the sun.

$$F_2 = \frac{m_2v^2}{R}$$

If $F_1 = F_2$ we get:

$$R^3 = kT^2$$

Which is true that

$$T^2 \propto R^3$$

Acceleration due to gravity at the surface of the earth

At the surface of the earth acceleration due to gravity is given by;

$$g = \frac{GM_e}{R^2}$$

This value is constant and its average value is taken to be 9.8 m/s^2

Variation of acceleration due to gravity with height

The acceleration due to gravity at a point above the surface of the earth is given by;

$$g' = g \left(\frac{R}{R+h} \right)^2$$

This value decreases as you move further from the surface of the earth.

Variation of gravity with depth

At a point below the surface of the earth, acceleration due to gravity is given by;

$$g' = \frac{4}{3} \pi \rho G (R-d)$$

The depth d is measured from the surface of the earth. The value of acceleration due to gravity increases as we move towards the surface. At centre of earth $g = 0$.

Variation in g Due to Rotation of Earth

As the earth rotates, a body placed on its surface moves along the circular path and hence experiences centrifugal force, due to which the apparent weight of the body decreases.

By solving, the acceleration due to gravity is given by;

$$g' = g - \omega^2 R \cos^2 \lambda$$

Variation of gravity g Due to Shape of Earth

The value of acceleration due to gravity will vary depending on someone's position at the surface of the earth as;

$$\text{At equator} \quad g_e = \frac{GM}{R_e^2}$$

$$\text{At poles} \quad g_p = \frac{GM}{R_p^2}$$

Rockets and spacecraft

A rocket is a device that produces thrust by ejecting stored matter. Spacecraft Propulsion is characterized in general by its complete integration within the spacecraft (e.g. satellites).

Satellites

A satellite is an artificial body placed in orbit round the earth or another planet in order to collect information or for communication.

Orbital Velocity of Satellite

$$v = R \sqrt{\frac{g}{R+h}}$$

Time Period of Satellite

The period of a satellite is given by;

$$T = 2\pi \sqrt{\frac{R}{g} \left(1 + \frac{h}{R}\right)^{3/2}}$$

Height of Satellite

The height at which a satellite is launched is given by;

$$h = \left(\frac{T^2 g R^2}{4\pi^2}\right)^{1/3} - R$$

Geostationary Satellite

The satellite which appears stationary relative to earth is called geostationary or geosynchronous satellite e.g. communication satellite.

Angular Momentum of Satellite

The angular momentum of a satellite is given by;

$$L = \sqrt{m^2 G M r}$$

It is seen that angular momentum of satellite depends on both the mass of orbiting and central body as well as the radius of orbit.

Energy of Satellite

When a satellite revolves around a planet in its orbit, it possesses both potential energy (due to its position against gravitational pull of earth) and kinetic energy (due to orbital motion).

(1) Potential energy : $U = mV = \frac{-GMm}{r}$

(2) Kinetic energy : $K = \frac{1}{2}mv^2 = \frac{GMm}{2r}$

Total energy (E) = $\frac{-GMm}{2r}$ constant

Types and applications of Satellite Systems

- GEO (Geo-stationary earth orbit)
- MEO (medium earth orbit)
- LEO (Low earth orbit) and
- HEO (Highly elliptical orbit)

Cosmic velocity

The first cosmic velocity

$$v_1 = 7900 \text{ m/s}$$

Second cosmic velocity

This is also called the escape velocity, $v_2 = 11200 \text{ m/s}$

Third cosmic velocity

The third cosmic velocity is the initial velocity which a body has to have to escape the Solar System and its value is given by;

$$v_3 = 16.7 \text{ km/s}$$

UNIT
9

ATOMIC MODELS AND PHOTOELECTRIC EFFECT



Key unit competence: Evaluate the atomic models and photoelectric effect

Unit Objectives:

By the end of this unit I will be able to;

- ◇ Describe different atomic models by explaining their concepts and drawbacks.
- ◇ Explain the photoelectric effect and its applications in everyday life.

Introductory Activity

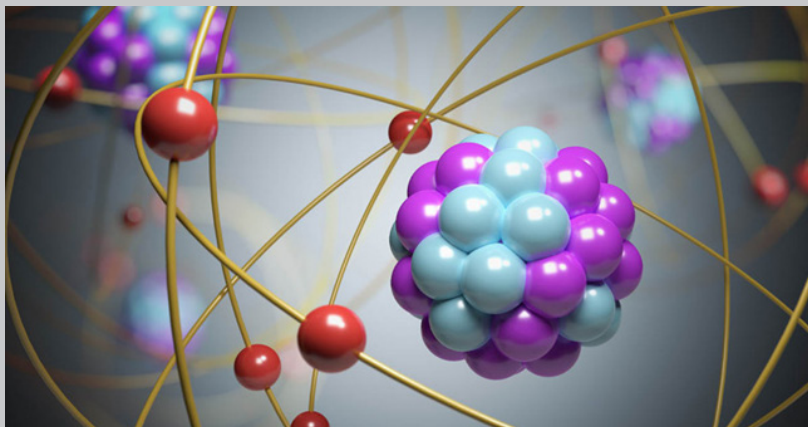

1. Basing on the figure above,
 - a. How is the structure/arrangement of balls shown in the figure related to an atom? You can use chemistry knowledge from O'level.
 - b. Relate the arrangement of electrons in an atom to how the balls in the figure above are arranged.
 - c. Explain how movement of particles in an atom leads to release or absorption of energy
4. It is important to realise that a lot of what we know about the structure of atoms has been developed over a long period of time. This is often how scientific knowledge develops, with one person building on the ideas of someone else. In attempt to explain an atom, different scientists suggest different models. An atomic model represents what the structure of an atom could look like, based on what we know about how atoms behave. It is not necessarily a true picture of the exact structure of an atom.
 - a. Why did these scientists use the word Model not exact structure of an atom?
 - b. Can you explain some of the scientific models that tried to explain the structure of an Atom?

9.0 INTRODUCTION

An atomic theory is a model developed to explain the properties and behaviours of atoms. An atomic theory is based on scientific evidence available at any given time and serves to suggest future lines of research about atoms.

The concept of an atom can be traced to debate among Greek philosophers

that took place around the sixth century B.C. One of the questions that interested these thinkers was the nature of matter. Is matter continuous or discontinuous? If you could break a piece of chalk as long as you wanted, would you ever reach some ultimate particle beyond which further division was impossible? Or could you keep up that process of division forever?

Such questions need the knowledge on the atomic structure and interaction with photoelectric effect to be answered. This theory is helpful in Chemistry (Atomic structure), Security (Alarm systems), Medicine, Archaeology, etc.

9.1 STRUCTURE OF THE ATOM AND THOMSON'S MODEL

structure of the atom

An atom is the smallest particle of an element that retains again the characteristics or the properties of that element during chemical reaction.

By the early 1900s scientists were able to break apart the atoms into particles that they called the **electron** and the **nucleus** which is made of **proton** and **neutrons**.

- **Electrons**

Electrons surround the dense nucleus of an atom. It is the smallest subatomic particle with a mass of $m_e = 9.109 \times 10^{-31} \text{ kg}$ and a negative electric charge. The electron is also one of the few elementary particles that is stable, meaning it can exist by itself for a long period of time. Most other elementary particles can exist independently for only a fraction of a second. Electrons have no detectable shape or structure.

The electrons revolve around the nucleus in fixed trajectory (orbits) called **energy levels** or **shell**. These shells have the names K, L, M, N, etc... The shell of atom just prior to the outermost shell of an atom cannot accommodate more than 8 electrons even it has a capacity to accommodate more electrons. The outermost shell (last shell) which contains electrons is called the conduction shell or **valence shell**. On each electron shell, we can meet $N = 2n^2$ electrons, where N is the number of the electron shell. The valence electrons which are not very attached to the nucleus are called free electrons. The **free electrons** can be easily detached from the atom by **application of a small external energy** (usually thermal energy by increasing the temperature).

- **Protons**

Proton is a subatomic particle with a positive charge. The charge is equal and opposite to that of an electron. The mass of a proton is 1840 times that of an electron. Thus the mass of an atom is mainly due to protons and neutrons. The proton is one of the few elementary particles that are stable—that is, it can exist by itself for a long period of time. The number of protons is called the **atomic number (Z)**.

In normal atom, the number of electrons is equal to the number of protons. The atomic number (Z) of an atom is equal to the number of protons (or electrons) contained in atom.

- **Neutron**

Neutron is a subatomic particle with a mass almost equal to the mass of a proton. It has no electric charge. The neutron is about 10-13 cm in diameter and weighs $m_n = 1.67 \times 10^{-27} \text{ kg}$.

The number of protons and neutrons is called **nucleons number**, or, alternatively, the **mass number (A)**. The mathematical relationship between atomic number (Z), mass number (A) and neutron number (n) is $A = z + n$

An atom is represented by a symbol like this ${}_{30}^{64}\text{Zn}$. This indicates $z = 30$ and $A = 64$, Zn is symbol element Zinc. For a proton the symbol is ${}^1_1\text{H}$ since the proton is the nucleus of hydrogen. A neutron is denoted by ${}_0^1n$ and electron by ${}_{-1}^0e$ where $A = 0$ because an electron is not composed of protons or neutrons and $z = -1$ because an electron has a negative charge. Nuclei that contain the same number of protons but a different number of neutrons are known as **isotopes**.

Thus ${}^6_6\text{C}$, ${}^{12}_6\text{C}$, ${}^{13}_6\text{C}$, ${}^{14}_6\text{C}$, ${}^{15}_6\text{C}$ and ${}^{16}_6\text{C}$ are all isotope of carbone. Hydrogen has isotope of ${}^1_1\text{H}$, ${}^2_1\text{H}$ (Deuterium) and ${}^3_1\text{H}$ (tritium)

The unit used to measure the mass of an atom is called the **atomic mass**

unit, abbreviated “**amu or u**” and is defined as a $\frac{1}{12}$ the mass of an atom of carbon-12 i.e.

$$u = \frac{1}{12} \frac{12 \times 10^{-3} \text{ kg / mol}}{6.023 \times 10^{23} \text{ atom / mol}} = 1.6605 \times 10^{-27} \text{ kg / atom}$$

Therefore $u = 1.6605 \times 10^{-27} \text{ kg} = 931.5 \text{ MeV} / c^2$

Atomic structure is the structure of the nucleus and of the extra nuclear electrons. The extra nuclear electrons are arranged in atomic shells.

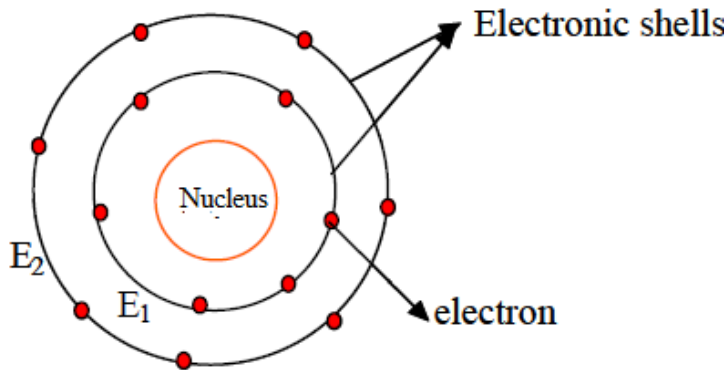

Fig.9. 1 The radius of the nucleus depends on the atomic mass A and is given by

$$r = (1.2 \times 10^{-15}) A^{\frac{1}{3}} \text{ and, the radius of the orbit is given by } r = (5.29 \times 10^{-10}) n^2$$

Thomson's model

English scientist **Joseph John Thomson's** cathode ray experiments (end of the 19th century) led to the discovery of the negatively charged electron and the first ideas of the structure of these indivisible atoms. In his model of the atom, **Sir J J Thomson** (1856-1940) suggested a model of atom as *"The atom is like a volume of positive charge with electrons embedded throughout the volume, much like the seeds in watermelon."* Fig.9.4

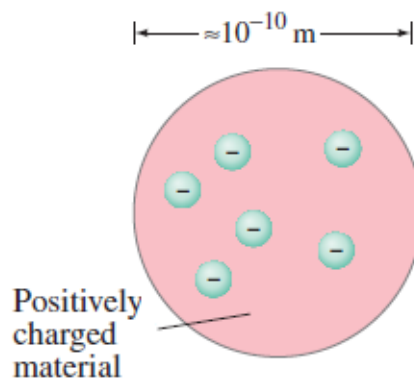

Fig.9. 2 the atom is a homogeneous sphere of positive charge inside of which there were tiny negatively charged electrons, a little like plums in a pudding

Success and Failure of Thomson's model

Thomson's model explained the phenomenon of thermionic emission, photoelectric emission and ionization. The model fails to explain the scattering of α -particles and it is the origin of spectral lines observed in the spectrum of hydrogen and other atoms.

9.2 RUTHERFORD'S ATOMIC MODEL

Rutherford performed experiments on the scattering of alpha particles by extremely thin gold foils and made the following observations;

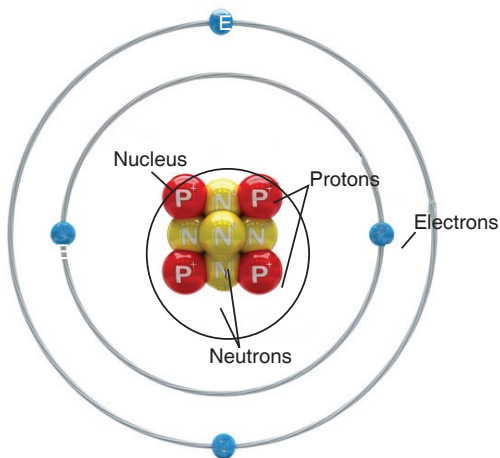

Fig. 9-1: Structure of an atom

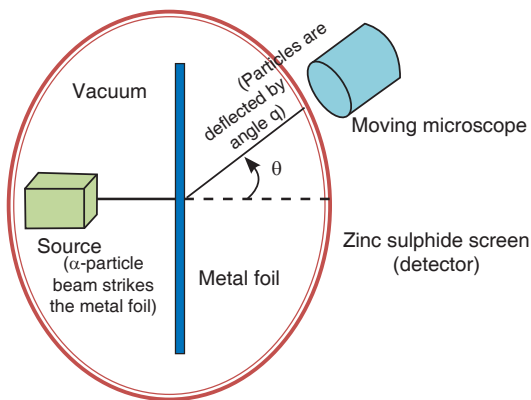

Fig. 9-2: Rutherford's experiment

Note:

- Some of α -particles are deflected through small angles.
- A few α -particles (1 in 1000) are deflected through the angle more than 90° .
- A few α -particles (very few) returned back *i.e.* deflected by 180° .
- Distance of closest approach (Nuclear dimension) is the minimum distance from the nucleus up to which the α -particle approach. It is denoted by r_0 . From figure

$$r_0 = \frac{1}{4\pi\epsilon_0}; \quad \text{.....Equation 9-1}$$

$$E = \frac{1}{2}mv^2 \quad \text{.....Equation 9-2}$$

Equation 9-2 is the equation of kinetic energy of α -particle.

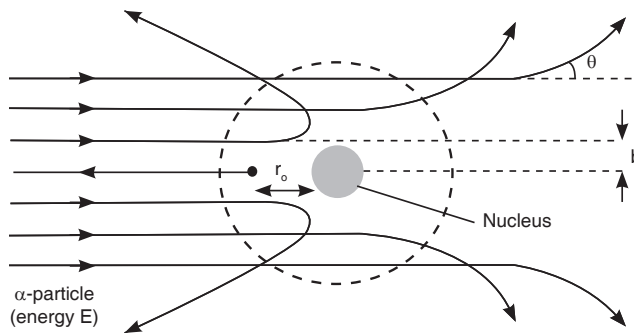

Fig. 9-3: Scattering of alpha particles

From these experiments a new model of the atom was born called Rutherford's planetary model of the atom. The following conclusions were made to describe the atomic structure:

- Most of the mass and all of the charge of an atom is concentrated in a very small region called atomic nucleus.
- Nucleus is positively charged and its size is of the order of $10^{-15} m$.
- In an atom there is maximum empty space and the electrons revolve around the nucleus in the same way as the planets revolve around the sun.

Drawbacks : Rutherford's model could not explain the following:

- **Stability of atom:** It could not explain the stability of atom because according to classical electrodynamics, an accelerated charged particle should continuously radiate energy. Thus, an electron moving in a circular path around the nucleus should also radiate energy and thus move into and smaller orbits of gradually decreasing radius and it should ultimately fall into nucleus.

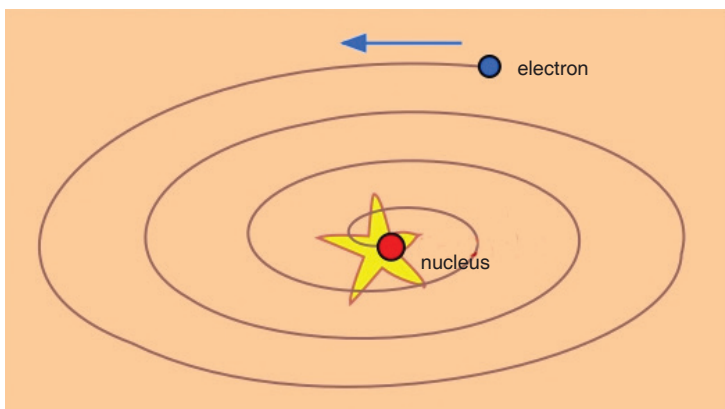

Fig. 9-4: Death spiral of the electron

- According to this model, the spectrum of atom must be continuous whereas practically it is a line spectrum.
- It did not explain the distribution of electrons outside the nucleus.

9.3 BOHR'S ATOMIC MODEL

Bohr proposed a model for hydrogen atom which is also applicable for some lighter atoms in which a single electron revolves around a stationary nucleus of positive charge Ze (called hydrogen like atom). Bohr's model is based on the following postulates:

- Each electron moves in a circular orbit centered at the nucleus.
- The centripetal force needed by the electron moving in a circle is provided by electrostatic force of attraction between the nucleus and electrons.
- The angular momenta p of electrons are whole number multiples of $\frac{h}{2\pi}$ where h is the Planck's constant. i.e.

$$p = \frac{nh}{2\pi} = mvr. \quad \text{.....Equation 9-3}$$

- When electron moves in its allowed orbit, it doesn't radiate energy. The atom is then stable. Such stable orbits are called stationary orbit.
- When an electron jumps from one allowed orbit to another, it radiates energy. The energy of radiation equals energy difference between levels.

$$hf = E_i - E_f$$

where h is Planck's constant and f is the frequency of radiation. When electron jumps from higher energy orbit (E_1) to lower energy orbit (E_2), then difference of energies of these orbits, i.e. $E_1 - E_2$ emits in the form of photon. But if electron goes from E_2 to E_1 it absorbs the same amount of energy.

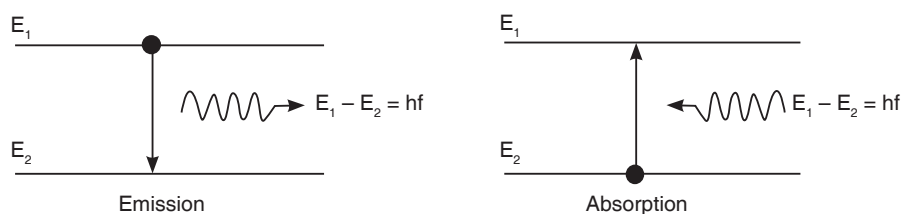

Fig. 9-5: Emission and absorption of radiation

Notes:

- According to Bohr theory, the momentum of an electron revolving in second orbit of H_2 atom will be $\frac{h}{\pi}$

- For an electron in the n th orbit of hydrogen atom in Bohr model, circumference of orbit = $n\lambda$; where λ = de-Broglie wavelength.

Bohr's Orbits (For Hydrogen and H_2 -Like Atoms).

A: Radius of orbit

For an electron around a stationary nucleus, the electrostatics force of attraction provides the necessary centripetal force, i.e.

$$\frac{1}{4\pi\epsilon_0} \frac{(Ze)e}{r^2} = \frac{mv^2}{r} \quad \text{.....Equation 9-4}$$

Also,
$$mvr = \frac{nh}{2\pi} \quad \text{.....Equation 9-5}$$

From equation 9-4 and 9-5, radius of n^{th} orbit

$$r_n = \frac{n^2 h^2}{4\pi^2 k Z m e^2} = \frac{n^2 h^2 \epsilon_0}{\pi m Z e^2} = 0.53 \frac{n^2}{Z} 10^{-10} \text{m} \quad \left[\text{Where } k = \frac{1}{4\pi\epsilon_0} \right]$$

$\Rightarrow r_n \propto \frac{n^2}{Z} \quad \text{.....Equation 9-6}$

Notes:

- The radius of the innermost orbit ($n = 1$) of hydrogen atom ($z = 1$) is called Bohr's radius a_0 , i.e. $a_0 = 0.53 \cdot 10^{-10} \text{m}$

B: Speed of electron

From the above relations, speed of electron in n th orbit can be calculated as

$$v_n = \frac{2\pi k Z e^2}{nh} = \frac{Z e^2}{2\epsilon_0 nh} = \left(\frac{c}{137} \right) \cdot \frac{z}{n} = 2.2 \times 10^6 \frac{z}{n} \text{ m/s}$$

where (c = speed of light $3 \times 10^8 \text{ m/s}$).

Notes:

- The ratio of speed of an electron in ground state in Bohr's first orbit of hydrogen atom to velocity of light in air is equal to $\frac{e^2}{2\epsilon_0 ch} = \frac{1}{137}$ (where c = speed of light in air).

Drawbacks of Bohr's atomic model

- It is valid only for single valency atoms, e.g. : H, He⁺², Li⁺, Na⁺¹ etc.
- Orbits were taken as circular but according to Sommerfeld these are elliptical.
- Intensity of spectral lines could not be explained.
- Nucleus was taken as stationary but it also rotates on its own axis.
- It could not explain the minute structure in spectral lines.
- This does not explain the Zeeman effect (splitting up of spectral lines in magnetic field) and Stark effect (splitting up in electric field)
- This does not explain the doublets in the spectrum of some of the atoms like sodium ($5890 \times 10^{-10} \text{m}$ & $5896 \times 10^{-10} \text{m}$)

9.4 ENERGY LEVELS AND SPECTRAL LINES OF HYDROGEN

When hydrogen atom is excited, it returns to its normal unexcited state (or ground state) by emitting the energy it had absorbed earlier. This energy is given out by the atom in the form of radiations of different wavelengths as the electron jumps down from a higher orbit to a lower orbit. Transition from different orbits causes different wavelengths. These constitute spectral series which are characteristic of the atom emitting them. When observed through a spectrocope, these radiations are imaged as sharp and straight vertical lines of a single colour.

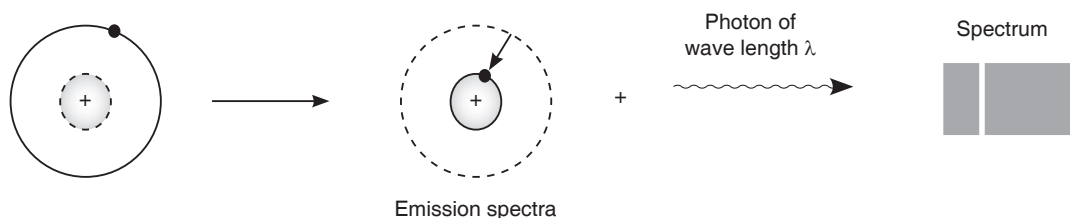

Fig. 9-6: Energy spectrum of hydrogen atom

The spectral lines arising from the transition of electron forms a spectra series. Mainly there are five series and each series is named after its discover as Lyman series, Balmer series, Paschen series, Brackett series and Pfund series. First line of the series is called first member, for which line wavelength is maximum (λ_{max}). Last line of the series ($n_2 = \infty$) is called series limit, for which line wavelength is minimum (λ_{min}).

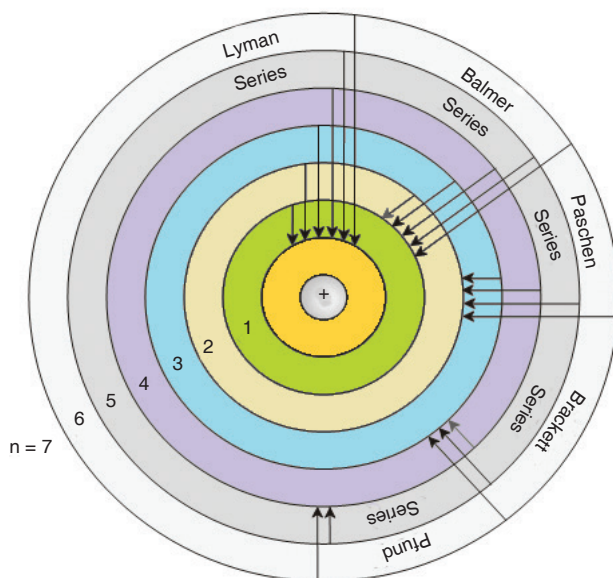

Fig. 9-7: Energy levels of Hydrogen atom

9.5 THERMIONIC EMISSION (THERMO ELECTRONIC EMISSION)

Thermionic emission means the discharge of electrons from heated materials. It is widely used as a source of electrons in conventional electron tubes (e.g., television picture tubes) in the fields of electronics and communications. The phenomenon was first observed (1883) by Thomas A. Edison as a passage of electricity from a filament to a plate of metal inside an incandescent lamp.

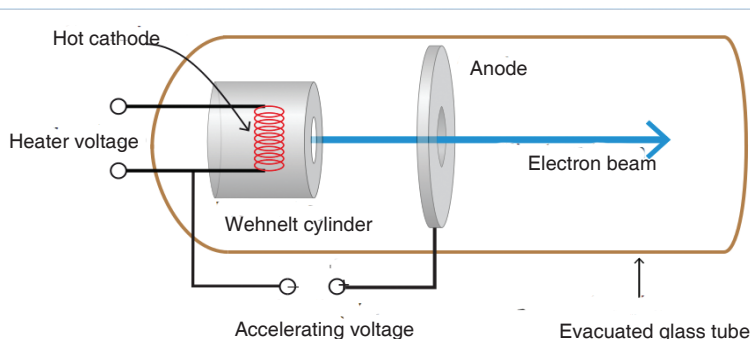

Fig. 9-8: Thermionic emission

In thermionic emission, the heat supplies some electrons with at least the minimal energy required to overcome the attractive force holding them in the structure of the metal. This minimal energy, called the work function, is the characteristic of the emitting material and the state of contamination of its surface.

9.6 APPLICATIONS OF CATHODE RAYS

9.6.1 Cathode ray oscilloscope

The cathode-ray oscilloscope (CRO) is a common laboratory instrument that provides accurate time and amplitude measurements of voltage signals over a wide range of frequencies. Its reliability, stability and ease of operation makes it suitable as a general purpose laboratory instrument.

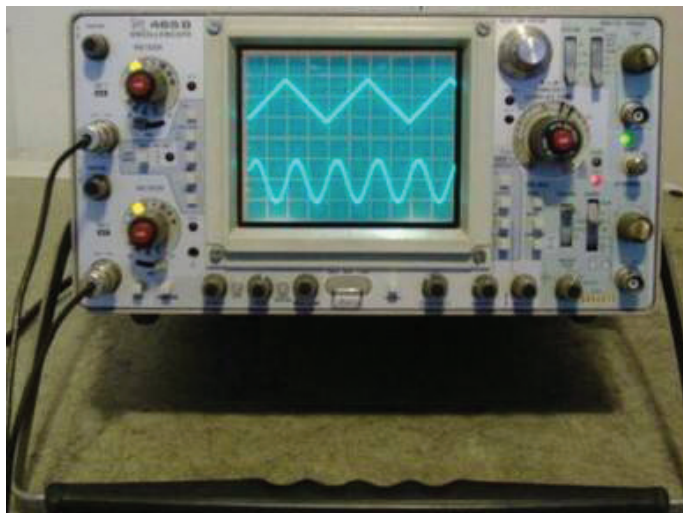

Fig. 9-9: Cathode Ray Oscilloscope (C.R.O)

The main part of the C.R.O. is a highly evacuated glass tube housing parts which generates a beam of electrons, accelerates them, shapes them into a narrow beam and provides external connections to the sets of plates changing the direction of the beam. The heart of the CRO is a cathode-ray tube shown schematically in Fig.9-10;

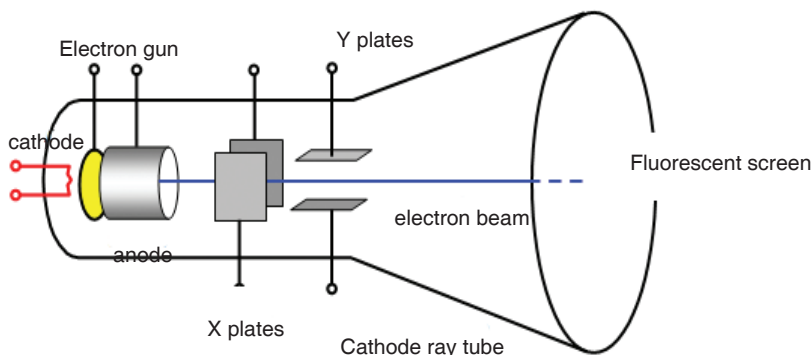

Fig.9-10: C.R.O tube

Working of a C.R.O

- An indirectly heated cathode provides a source of electrons for the beam by ‘boiling’ them out of the cathode.
- The anode is circular with a small central hole. The potential of anode creates an electric field which accelerates the electrons, some of which emerge from the hole as a fine beam. This beam lies along the central axis of the tube.
- The grid has the main function of concentrating the beam at the centre controlling the potential of the grid that controls the number of electrons for the beam, and hence the intensity of the spot on the screen where the beam hits.
- X and Y are two deflection plates. The X plates are used for deflecting the beam from left to right (the x-direction) by means of the ‘ramp’ voltage. The Y plates are used for deflection of the beam in the vertical direction. Voltages on the X and Y sets of plates determine where the beam will strike the screen and cause a spot of light.
- The screen coated on the inside with a fluorescent material which shines with green light (usually) where the electrons are striking.

9.6.2 TV tubes

The picture tube is the largest component of a television set, consisting of four basic parts. The glass face panel is the screen on which images appear. Suspended immediately behind the panel is a steel shadow mask, perforated with thousands of square holes. (Connected to the mask is a metal shield to neutralize disruptive effects of the Earth’s magnetic field.) The panel is fused to a glass funnel, which comprises the rear of the picture tube. The very rear of the funnel converges into a neck, to which an electron gun assembly is connected.



Fig. 9-11: TV picture tube

The inside of the panel is painted with a series of very narrow vertical stripes, consisting of red, green and blue phosphors. These stripes are

separated by a narrow black graphite stripe guard band. When struck by an electron beam, the phosphors will illuminate, but the graphite will not. This prevents colour impurity by ensuring that the electron beam only strikes the phosphor stripes it is intended to light.

The electron beam is generated by the electron gun assembly, which houses three electron guns situated side-by-side. Each of the three guns emits an electron beam (also called a cathode ray) into the tube, through the mask and onto the panel.

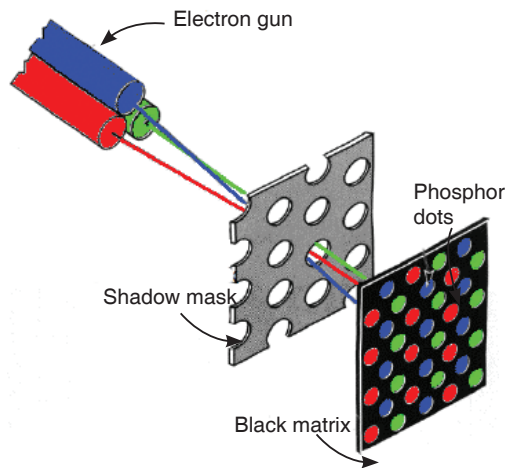

Fig. 9-12: Phosphors on the screen

Because the three beams travel side-by-side, the holes in the mask ensure that each beam, because of its different angle of attack, will hit only a specific phosphor stripe; red, green or blue. The three phosphors, lighted in different combinations of intensity, can create any visible colour when viewed from even a slight distance.

The three electron beams are directed across the screen through a series of electromagnets, called a yoke, which draw the beams horizontally across the screen in line at a time. Depending on the screen size, the beam draws about 500 lines across the entire screen. Each time, the phosphors light up to produce an image.

The electron guns and the yoke are electronically synchronized to ensure the lines of phosphors are lighted properly to produce an accurate image. The image lasts only for about a $\frac{1}{30}$ th of a second. For that reason, the picture must be redrawn 30 times in a second. The succession of so many pictures produces the illusion of movement, just like the frames on movie film.

9.7 FLUORESCENCE AND PHOSPHORESCENCE

Fluorescence is the emission of light by a substance that has absorbed light or other electromagnetic radiation. It is a form of **photoluminescence**. In most cases, the emitted light has a longer wavelength, and therefore, lower energy than the absorbed radiation. However, when the absorbed electromagnetic radiation is intense, it is possible for one electron to absorb two photons; this two-photon absorption can lead to emission of radiation having a shorter wavelength than the absorbed radiation. The emitted radiation may also be of the same wavelength as the absorbed radiation, termed “resonance fluorescence”.

Fluorescence occurs when an orbital electron of a molecule or atom relaxes to its ground state by emitting a photon of light after being excited to a higher quantum state by some type of energy. The most striking examples of fluorescence occur when the absorbed radiation is in the ultraviolet region of the spectrum, and thus invisible to the human eye, and the emitted light is in the visible region.

Phosphorescence is a specific type of photoluminescence related to fluorescence. Unlike fluorescence, a phosphorescent material does not immediately re-emit the radiation it absorbs. Excitation of electrons to a higher state is accompanied with the change of a spin state. Once in a different spin state, electrons cannot relax into the ground state quickly because the re-emission involves quantum mechanically forbidden energy state transitions. As these transitions occur very slowly in certain materials, absorbed radiation may be re-emitted at a lower intensity for up to several hours after the original excitation.

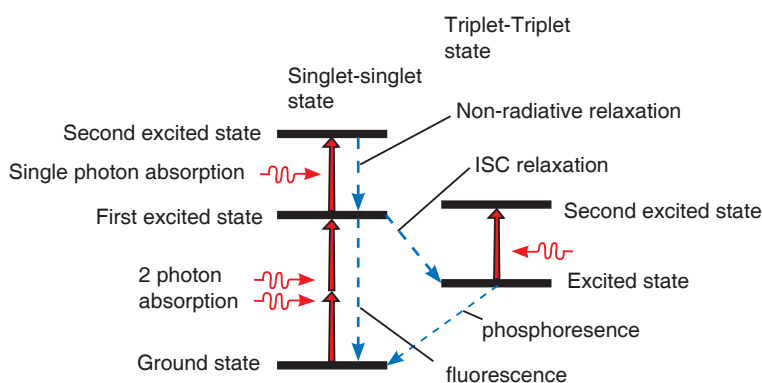

Fig. 9-13: Energy scheme used to explain the difference between fluorescence and phosphorescence

9.8 PHOTOELECTRIC EMISSION LAWS

Law 1:

The photocurrent is directly proportional to the intensity of light and is independent of frequency.

Explanation

According to quantum theory, each photon interacts only with each electron. When the intensity is increased more photons will come and they will interact with more electrons. This will increase the amount of photo current.

Law 2:

The kinetic energy of the photoelectrons is directly proportional to frequency and is independent of intensity.

Explanation

According to Einstein's equation, hf_0 is constant. Then kinetic energy is directly proportional to frequency.

Law 3:

Photoelectric effect does not happen when the incident frequency is less than a minimum frequency (threshold frequency).

Explanation

From Einstein's equation, if $f < f_0$, then kinetic energy becomes negative and it is impossible, in other words photoelectric effect does not happen.

Law 4:

There is no time lag between the incidence of photon and emission of electrons. Thus, photoelectric process is instantaneous.

Explanation

According to quantum theory, each photon interacts with each electron. So different electrons will interact with different photons at same instant. Thus there is no time lag between incidence and emission.

9.9 PHOTOELECTRIC EFFECT

The **photoelectric effect** is the emission of electrons from the surface of a metal when electromagnetic radiation (such as visible or ultraviolet light) shines on the metal. At the time of its discovery, the classical wave model for light predicted that the energy of the emitted electrons will increase as the intensity (brightness) of the light increased. It was discovered that it did not behave that way. Instead of using the wave model, treating light as a particle (photon) led to a more consistent explanation of the observed behaviour.

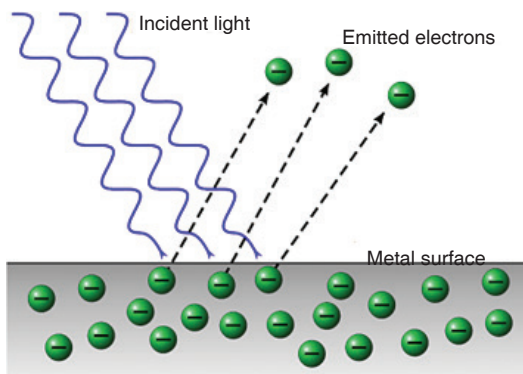

Fig. 9-14: Photoelectric emission

From photon theory, we note that in a monochromatic beam, all photons have the same energy (equal to hf). Increasing the intensity of the light beam means increasing the number of photons in the beam but does not affect the energy of each photon as long as the frequency is not changed.

From this consideration and suggestions of Einstein, the photon theory makes the following predictions:

1. For a given metal and frequency of incident radiation, the number of photoelectrons ejected per second is directly proportional to the intensity of the incident light.
2. For a given metal, there exists a certain minimum frequency (f_0) of incident radiation below which no emission of photoelectrons takes place. This frequency is called the **threshold frequency** or **cutoff frequency**.
3. Above the threshold frequency, the **maximum kinetic energy of the emitted photoelectron** is independent of the intensity of the incident light but depends only upon the frequency (or wavelength) of the incident light.
4. The time lag between the incidence of radiation and the emission of a photoelectron is very small (less than 10^{-9} second).

This is **evidence of the particle nature of light**.

9.10 FACTORS AFFECTING PHOTOELECTRIC EMISSION

Photoelectric current is produced as a result of photoelectric effect. Therefore, understanding the factors which influence the photoelectric effect is very important. The previous studies on photoelectric effect have presented the following factors which may have a direct impact on photoelectric effect.

Intensity of Light:

If a highly intense light of frequency equal to or greater than threshold frequency falls on the surface of matter, the photoelectric effect is caused. Studying the impact of this factor is the focus of this research study. One thing which is very clear is that the emission of electrons does not depend upon the intensity of light unless the frequency of light is greater than the threshold frequency. The threshold frequency varies from matter to matter.

Number of Photoelectrons:

The increase in intensity of light increases the number of photoelectrons, provided the frequency is greater than threshold frequency. In short, the number of photoelectrons increases the photoelectric current.

Kinetic Energy of Photoelectrons:

The kinetic energy of photoelectrons increases when light of high energy falls on the surface of matter. When energy of light is equal to threshold energy, then electrons are emitted from the surface, whereas when energy is greater than threshold energy, then photoelectric current is produced. The threshold frequency is not same for all kinds of matter and it varies from matter to matter.

9.11 PHOTON, WORK FUNCTION AND PLANCK'S CONSTANT

The **photon** is the fundamental particle of visible light. In some ways, visible light behaves like a wave phenomenon, but in other respects it acts like a stream of high-speed, submicroscopic particles.

Minimum amount of energy which is necessary to start photo electric emission is called **Work Function**. If the amount of energy of incident radiation is less than the work function of metal, no photo electrons are emitted.

Planck's constant describes the behaviour of particles and waves on the atomic scale. The idea behind its discovery, that energy can be expressed in discrete units, or quantized, proved fundamental for the development of quantum mechanics.

Planck introduced the constant ($h = 6.63 \times 10^{-34}$ J.s) in his description of the radiation emitted by a blackbody (a perfect absorber of radiant energy). The constant's significance, in this context, was that radiation (light, for example) is emitted, transmitted and absorbed in discrete energy packets.

Project 9-1: Photoelectric Effect

Aim: this project aims at gaining the deep knowledge on photoelectric effect.

Question: Describe the observations made of the photoelectric effect and how this supports the particle model and wave model of light studied in unit 1.

Hypothesis: write a hypothesis on the phenomenon of photoelectric effect.

Procedure

1. State the main principle of photoelectric effect.
2. Outline your observations on different conditions

Collecting Data

Use internet and textbooks to analyse the phenomenon of photoelectric effect.

Report design

Write your report of at least five supporting points including the one given in the format below:

Observation	Wave model	Particle model
Even weak, low intensity light can release electrons instantly	Weak light waves should not provide enough energy to do this	Low intensity means fewer photons but each photon can still release an electron

9.12 EINSTEIN'S EQUATION

According to Einstein's theory, an electron is ejected from the metal by a collision with a single photon. In the process, all the photon energy is transferred to the electron and the photon ceases to exist. Since electrons are held in the metal by attractive forces, a minimum energy (W_0) is required just to get an electron out through the surface. W_0 is called the **work function**, and is a few electron volts ($1\text{eV} = 1.6 \times 10^{-19}$ J) for most metals.

Definitions

Photoelectric emission is the phenomenon of emission of electrons from the surface of metals when the radiations of suitable frequency and suitable wavelength fall on the surface of the metal.

Work function is the minimum energy required to set free an electron from the binding forces on the metal surface.

The **Threshold Frequency** is defined as the minimum frequency of incident light required for the photoelectric emission.

If the frequency f of the incoming light is so low that hf is less than W_0 , then the photons will not have enough energy to eject any electrons at all. If $hf > W_0$, then electrons will be ejected and energy will be conserved in the process.

So Einstein suggested that the energy of the incident radiation hf was partly used to free electrons from the binding forces on the metal and the rest of the energy appeared as kinetic energy of the emitted electrons. This is stated in the famous Einstein's equation of photoelectric effect as stated in equation 9-7 below.

$$hf = W_0 + K.e_{max} \quad \text{.....Equation 9-7}$$

$$W_0 = hf_0 \quad \text{.....Equation 9-8}$$

Equation 9-8 is called the Einstein's photoelectric equation.

Many electrons will require more energy than the bare minimum W_0 to get out of the metal, and thus the kinetic energy of such electrons will be less than the maximum.

Application Activity 9.1

Match the mathematical symbols and their descriptions

II Match them up:

The diagram shows the equation $E_k = hf - \Phi$ in a central box. Eight other boxes are connected to it by lines, representing the following descriptions:

- Planck's constant
- Maximum kinetic energy of an emitted photoelectron
- Minimum energy needed to emit an electron
- Measured in Joules
- Work function
- Measured in Hertz
- Frequency of incident radiation
- Measured in Joules

Stopping potential

The circuit is exposed to radiations of light of frequency f and the supply of potential difference V is connected as shown in Fig.9-15 below. The cathode C is connected at the positive terminal of the supply and the anode P is connected on the negative terminal of the supply.

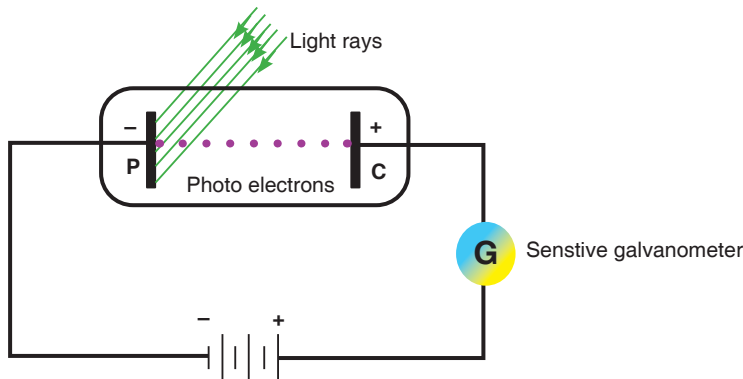

Fig. 9-15: Photoelectric circuit

If the circuit is exposed to radiations with the battery reversed as shown in Fig. 9-16, current reduces due to the fact that all electrons emitted are not able to reach the anode P. If this potential difference is increased until no electron reaches the anode P, no current flows and this applied potential is called a stopping potential.

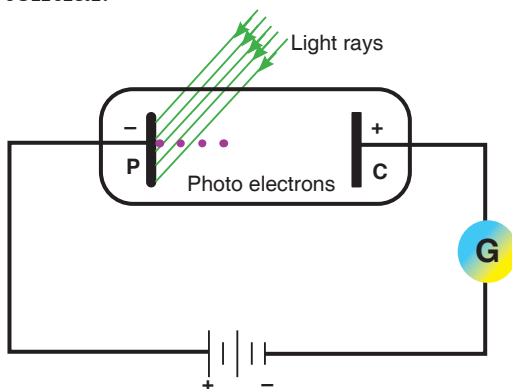

Fig. 9-16: Reverse potential on a Photoelectric circuit

For this case, the kinetic energy of electrons is given by;

$$\frac{1}{2}mv^2 = eV_s \quad \text{.....Equation 9-9}$$

where e is electron charge and V_s is the stopping potential. So, equation 9-7 becomes;

$$hf = W_0 + eV_s \text{ but,}$$

$$W_0 = hf_0 \text{ therefore,}$$

∴

$$eV_s = hf - hf_0 \quad \dots\dots\dots \text{Equation 9-10}$$

$$\Rightarrow V_s = \frac{h}{e}(f - f_0) \quad \dots\dots\dots \text{Equation 9-11}$$

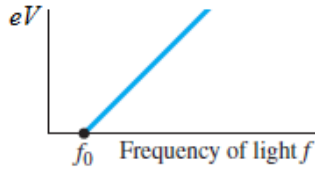

EXAMPLE 9-1

The work function for lithium is 4.6×10^{-19} J.

- Calculate the lowest frequency of light that will cause photoelectric emission.
- What is the maximum energy of the electrons emitted when the light of frequency 7.3×10^{14} Hz is used?

Solution:

(a)

$$W_0 = hf_0$$

$$\therefore f_0 = \frac{W_0}{h}$$

$$= \frac{4.6 \times 10^{-19}}{6.63 \times 10^{-34}} = 6.94 \times 10^{14} \text{ Hz}$$

(b) From equation 9.7,

$$hf = W_0 + K.e_{\text{max}}$$

$$\Rightarrow K.e_{\text{max}} = hf - W_0$$

$$\begin{aligned} \Rightarrow K.e_{\text{max}} &= 6.63 \times 10^{-34} \times 7.30 \times 10^{14} - 4.60 \times 10^{-19} \\ &= 0.24 \times 10^{-19} \text{ J} \end{aligned}$$

EXAMPLE 9-2

Selenium has a work function of 5.11 eV. What frequency of light would just eject electrons?

Solution:

When electrons are just ejected from the surface, their kinetic energy is zero.

So,

$$hf = W_0$$

$$\Rightarrow f = \frac{W_0}{h}$$

$$= \frac{5.11 \times 1.6 \times 10^{-19}}{6.63 \times 10^{-34}}$$

$$= 1.23 \times 10^{15} \text{ Hz}$$

Application Activity 9.2

1. Complete table 1 below.

Table 1: Applying Einstein's photoelectric equation in calculations

Metal	Work Function/eV	Work Function/J	Frequency used /Hz	Maximum KE of Ejected electrons/J
Sodium	2.28		6×10^{14}	
Potassium		3.68×10^{-19}		0.32×10^{-19}
Lithium	2.9		1×10^{15}	
Aluminium	4.1			0.35×10^{-19}
Zinc	4.3			1.12×10^{-19}
Copper		7.36×10^{-19}	1×10^{15}	

2. The stopping potential when a frequency of 1.61×10^{15} Hz is incident on a metal is 3 V.
 - (a) What is energy transferred by each photon?
 - (b) Calculate the work function of the metal.
 - (c) What is the maximum speed of the ejected electrons?

Aim: To know the concepts and use of photoelectric equation.

3. It is useful to observe the photoelectric effect equation represented graphically.

- (a) Express equation 9-7 in the form $y = a + b$, hence or otherwise, explain how Planck's constant can be calculated from the graph.
- (b) Express equation 9-8 in the form $y = ax + b$, hence or otherwise explain how Planck's constant can be calculated from the graph.

Aim: To graphically analyse the use of photoelectric equation.

4. In an experiment to measure the Planck's constant, a light emitting diode (LED) was used. Fig. 1-6 was plotted for varying energy of the photon and frequency of the diode. Use the graph to answer the questions that follow.

Plot of LED frequency (Hz) against photon energy (eV)

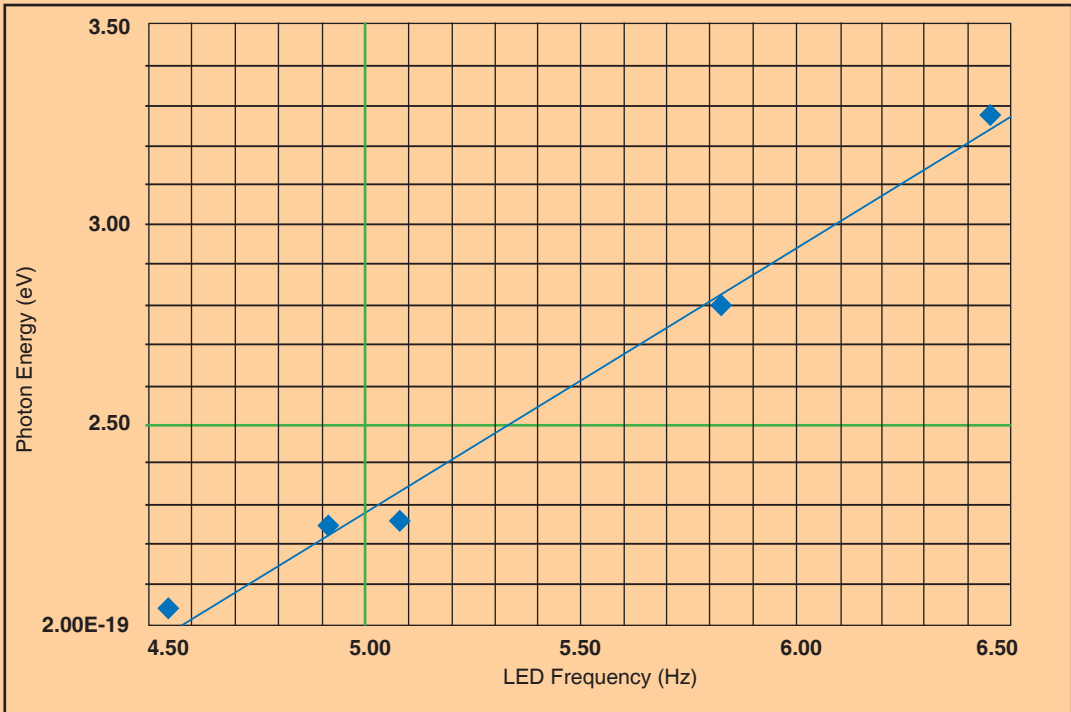

Fig. 9-17: Determination of Planck's constant

- Determine the slope of the line.
- What are the intercepts of the graph?
- Write down the equation of the line.
- What do you think is the vertical intercept?
- What is the value of the Planck's constant?
- Write the Einstein photoelectric equation in relation to the answer of (e).

9.13 APPLICATION OF PHOTOELECTRIC EFFECT (PHOTO EMISSIVE AND PHOTOVOLTAIC CELLS)

a) Photo electric cell

Photoelectric effect is applied in photoelectric cells or simply photocells. These cells change light energy into electric current. Photoelectric cell makes use of photoelectric effect and hence converts light energy into electrical energy. The strength of the current depends on the intensity of light falling on the cathode.

A photocell consists of an evacuated tube which is transparent to radiations falling on it. It contains two electrodes; a semi-cylindrical cathode coated with photosensitive material and an anode consisting of a straight wire or loop.

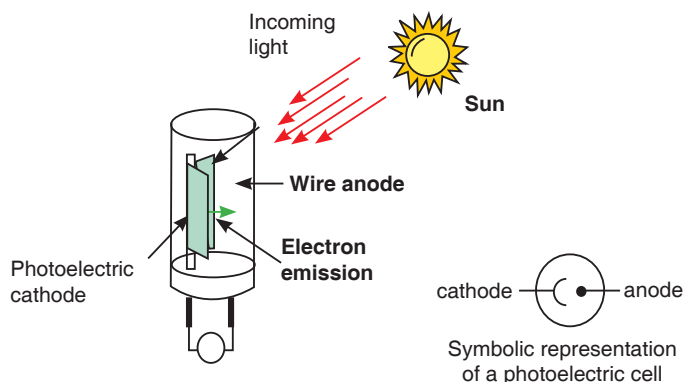

Fig. 9-18: Photocell design and symbol

When radiations fall on the cathode, photoelectrons are emitted which are collected by the anode if it is positive with respect to the cathode. They, then, go through the external circuit causing electric current. As intensity of radiations increases, the number of electrons emitted by photoelectric effect also increases. Hence current also increases.

An everyday example is a solar powered calculator and a more exotic application would be solar panels and others.

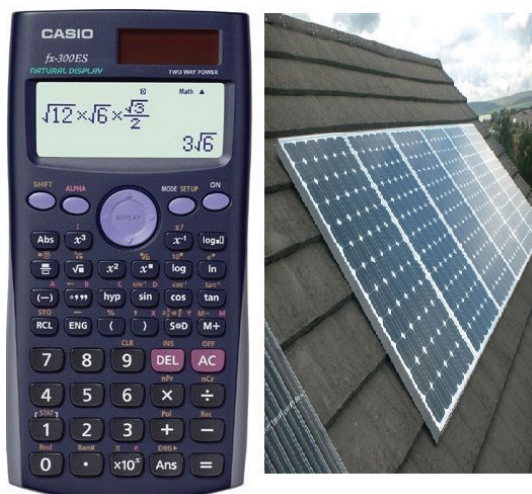

Fig. 9-19: devices which use photocells

b) Automatic door opener

- Automatic doors operate with the help of sensors. Sensors do exactly what they sound like they would do:
They sense things. There are many different types of sensors that can sense different types of things, such as sound, light, weight, and motion.

c) Smoke detectors

- Photoelectric Smoke Detectors. A photoelectric smoke detector is characterized by its use of light to detect fire. The alarm detects smoke; when smoke enters the chamber, it deflects the light-emitting diode light from the straight path into a photo sensor in a different compartment in the same chamber.

d) Remote control

- An Infra-Red (IR) remote (also called a transmitter) uses light to carry signals from the remote to the device it controls. It emits pulses of invisible infrared light that correspond to specific binary codes. Radio-frequency remotes work in a similar way.

9.14 COMPTON EFFECT

Convincing evidence that light is made up of particles (photons) and photons have momentum can be seen when a photon with high energy hf collides with a stationary electron.

Compton effect says that when x-rays are projected on the target, they are scattered after hitting the target and change the direction they were moving. This means that as a photon interacts with a free electron, the process of photon absorption is forbidden by conservation laws, but the

photon scattering may occur. If the electron was originally at rest, then, as a result of interaction, it acquires a certain velocity.

The energy conservation laws require that the photon energy decreases by the value of the electron kinetic energy, which means that its frequency must also decrease. At the same time, from the viewpoint of the wave theory, the frequency of scattered light must coincide with the frequency of incident light.

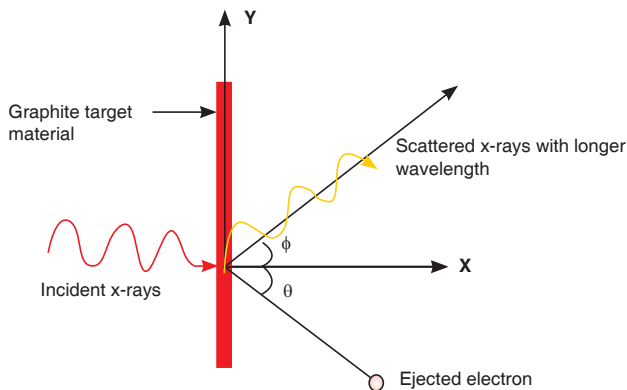

Fig. 9-20: Compton Effect

The momentum of the photon can be calculated as follows;

Energy of the photon (E) is, $E = mc^2$

$$\Rightarrow m = \frac{E}{c^2}$$

And momentum, $P = mc$

$$\therefore P = \frac{E}{c^2} \times c$$

$$\Rightarrow P = \frac{E}{c} \quad \text{.....Equation 9-12}$$

But $E = hf = \frac{hc}{\lambda}$

$$\therefore P = \frac{hc}{\lambda} \cdot \frac{1}{c}$$

$$\Rightarrow P = \frac{h}{\lambda} \quad \text{.....Equation 9-13}$$

Compton scattering equation : $\lambda' - \lambda = \frac{h}{m_e c} (1 - \cos \theta)$

The photon scattering on an electron can be considered as an elastic collision of two particles obeying the energy and momentum conservation laws

END OF UNIT ASSESSMENT

1. Describe briefly the two conflicting theories of the structure of the atom.
2. Why was the nuclear model of Rutherford accepted as correct?
3. What would have happened if neutrons had been used in Rutherford's experiment? Explain your answer.
4. What would have happened if aluminium had been used instead of gold in the alpha scattering experiment? Explain your answer.
5. What three properties of the nucleus can be deduced from the Rutherford scattering experiment? Explain your answer.
6. Monochromatic light of wavelength 560 nm incident on a metal surface in a vacuum photocell causes a current through the cell due to photoelectric emission from the metal cathode. The emission is stopped by applying a positive potential of 1.30 V to the cathode with respect to the anode. Calculate:
 - (a) the work function of the metal cathode in electron volts.
 - (b) the maximum kinetic energy of the emitted photoelectrons when the cathode is at zero potential.
7. In a Compton scattering experiment, the wavelength of scattered X-rays for scattering angle of 45 degree is found to be 0.024 angstrom.
 - (a) What is the wavelength of the incident photon?
 - (b) What is the percentage change in the wavelength on Compton scattering?
8. You use 0.124-nm x-ray photons in a Compton-scattering experiment.
 - (a) At what angle is the wavelength of the scattered x-rays 1.0% longer than that of the incident x-rays?
 - (b) At what angle is it 0.050% longer?
9.
 - (a) What is the energy in joules and electron volts of a photon of 420-nm violet light?
 - (b) What is the maximum kinetic energy of electrons ejected from calcium by 420-nm violet light, given that the binding energy (or work function) of electrons for calcium metal is 2.71 eV?
10. An electron and a positron, initially far apart, move towards each other with the same speed. They collide head-on, annihilating each other and

producing two photons. Find the energies, wavelengths and frequencies of the photons if the initial kinetic energies of the electron and positron are

- (a) both negligible and
 - (b) both 5.000 MeV. The electron rest energy is 0.511 MeV.
11. (a) Calculate the momentum of a visible photon that has a wavelength of 500 nm.
- (b) Find the velocity of an electron having the same momentum.
- (c) What is the energy of the electron, and how does it compare with the energy of the photon?
12. For an electron having a de Broglie wavelength of 0.167 nm (appropriate for interacting with crystal lattice structures that are about this size):
- (a) Calculate the electron's velocity, assuming it is non-relativistic.
 - (b) Calculate the electron's kinetic energy in eV.

UNIT SUMMARY

Structure of atom

An atom is a sphere in which positively charged particles called protons and negatively charged particles called electrons are embedded.

Rutherford's atomic model

Rutherford performed experiments by the scattering of alpha particles on extremely thin gold foils. From these experiments, a new model of the atom called Rutherford's planetary model of the atom was born. The following conclusions were made as regard as atomic structure:

- Most of the mass and all of the charge of an atom concentrated in a very small region which is called atomic nucleus.
- Nucleus is positively charged and its size is of the order of 10^{-15} m \approx 1 Fermi.
- In an atom, there is maximum empty space and the electrons revolve around the nucleus in the same way as the planets revolve around the sun.

Bohr's atomic model

Bohr's model is based on the following postulates:

- Each electron moves in a circular orbit centered at the nucleus.
- The centripetal force needed to the electron moving in a circle is provided by electrostatic force of attraction between the nucleus and electrons.

- The angular momenta of electrons are whole number multiples of $\frac{h}{2\pi}$ where h is the Planck number. i.e. $p = \frac{nh}{2\pi} = mvr$.
- When electron moves in its allowed orbit, it doesn't radiate energy. The atom is then stable, such stable orbits are called stationary orbits.
- When an electron jumps from one allowed orbit to another it radiates energy. The energy of radiation equals energy difference between levels.

$$hf = E_i - E_f$$

Energy levels and spectral lines of Hydrogen

When hydrogen atom is excited, it returns to its normal unexcited (or ground state) state by emitting the energy it had absorbed earlier. Transition from different orbits cause different wavelengths. These constitute spectral series which are characteristic of the atom emitting them.

The spectral lines arising from the transition of electron forms a spectra series. Mainly there are five series and each series is named after its discover as Lyman series, Balmer series, Paschen series, Brackett series and Pfund series.

Thermionic emission

Thermionic emission or discharge of electrons from heated materials, is widely used as a source of electrons in conventional electron tubes (e.g., television picture tubes) in the fields of electronics and communications.

Applications of cathode rays

- Cathode ray oscilloscope
- TV tubes

Fluorescence and phosphorescence

Fluorescence is the emission of light by a substance that has absorbed light or other electromagnetic radiation.

Phosphorescence is a specific type of photoluminescence related to fluorescence. Unlike fluorescence, a phosphorescent material does not immediately re-emit the radiation it absorbs.

Photoelectric emission laws'

Law 1: The photo current is directly proportional to the intensity of light and is independent of frequency.

Law 2: The kinetic energy of the photo electrons is directly proportional to frequency and is independent of intensity.

Law 3: Photoelectric effect does not happen when the incident frequency is

less than a minimum frequency (threshold frequency).

Law 4: There is no time lag between the incidence of photon and emission of electrons.

Photoelectric effect

The photoelectric effect is the emission of electrons from the surface of a metal when electromagnetic radiation (such as visible or ultraviolet light) shines on the metal.

Factors affecting photoelectric emission

- Intensity of Light:
- Frequency:
- Number of Photoelectrons
- Kinetic Energy of Photoelectrons

Einstein's equation photoelectric effect

Einstein suggested that the energy of the incident radiation hf was partly used to free electrons from the binding forces on the metal and the rest of the energy appeared as kinetic energy of the emitted electrons and his famous equation is;

$$hf = W_o + K.e_{max}$$

If the reverse potential difference applied on the circuit is increased until no electron reaches the anode, no current flows and this applied potential is called a stopping potential. This changes the Einstein's photoelectric equation to;

$$V_s = \frac{h}{e}(f - f_o)$$

Application of photoelectric effect

Photoelectric effect is applied in photoelectric cells or simply photocells. These cells change light energy into electric current. Photoelectric cell makes use of photoelectric effect and hence converts light energy into electrical energy. The strength of the current depends on the intensity of light falling on the cathode.

Compton effect

Compton effect says that when x-rays are projected on the target, they are scattered after hitting the target and change the direction they were moving.

The Compton equation (or Compton shift) is given by;

$$\lambda' - \lambda = \frac{h}{mc}(1 - \cos \phi)$$

UNIT
10

ANALOG AND DIGITAL SIGNALS

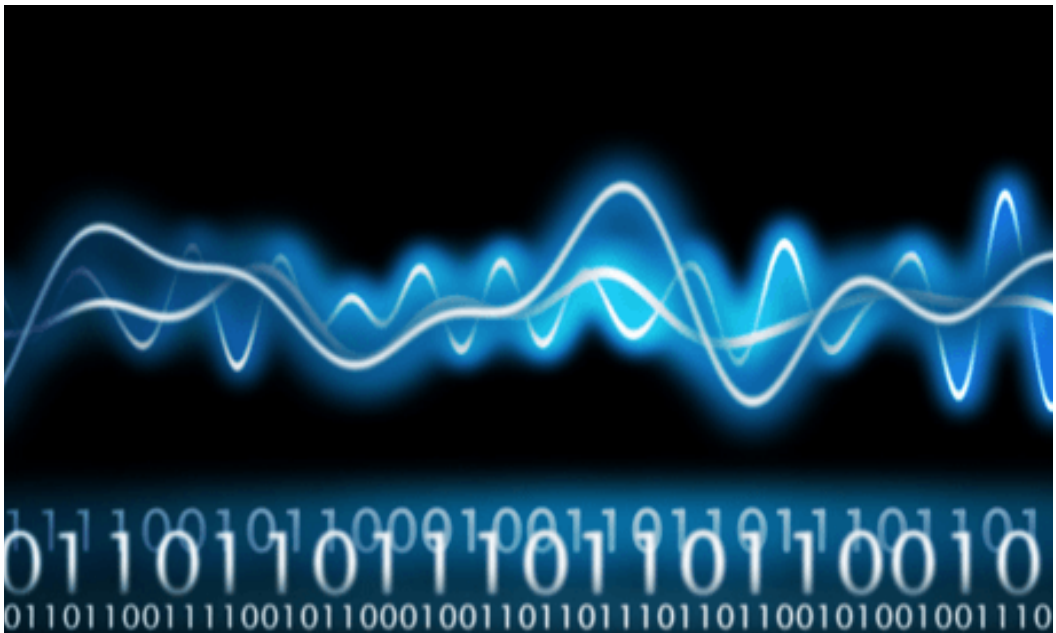

Key unit competence: Differentiate analog from digital signals.

Unit Objectives:

By the end of this unit I will be able to;

- ◇ Explain the transmission of information in a communication system.
- ◇ Explain with examples the use of digital and analog signals in everyday applications.

Introductory Activity

- a. There has been a move by the government of Rwanda to make her citizens to change from using analog devices to digital devices. Analog devices transmit and receive signals in analog form whereas digital devices transmit and receive signals digitally.
- b. a) What are different forms of signals you know that you normally use in daily life communication?
- c. b) Why do you think there is a need to change from analog to digital signal transmission?
- d. c) Mutesi communicates to her brother Ndayisenga who studies abroad using Facebook. Is the flow of information analog or digital? Explain your argument.
- e. d) Using information gained in above questions, discuss different signals you know.

10.1 INTRODUCTION

A signal is any kind of physical quantity that conveys information. Audible speech is certainly a kind of signal, as it conveys the thoughts (information) of one person to another through the physical medium of sound. Hand gestures are signals too. This text is another kind of signal, interpreted by your English-trained mind as information about electric circuits. In this unit, the word signal will be used primarily in reference to an electrical quantity of voltage or current that is used to represent or signify some other physical quantity.

A communication system is made up of devices that employ one of two communication methods (wireless or wired), different types of equipment (portable radios, mobile radios, base/fixed station radios and repeaters) accessories (examples include speaker microphones, battery eliminators and carrying cases) and/or enhancements (encryption, digital communications, security measures, and networking) to meet the user needs.

The most common processing of a signal in a communication system consists of passing the signal through a linear time-invariant system. In this context, such a system is often spoken of as a “filter”. These systems are usually applied to reduce some undesirable components in the signal, to compensate for some undesirable distortion of the signal, or to accentuate some characteristic of a signal. This unit discusses digital and analog signals and their use in modern communication.

10.2 INFORMATION TRANSMISSION IN A COMMUNICATION SYSTEM

A communication system comprises of three sections or parts; transmitting end, propagation medium and receiving end. This is shown on Fig. 10.1 below.

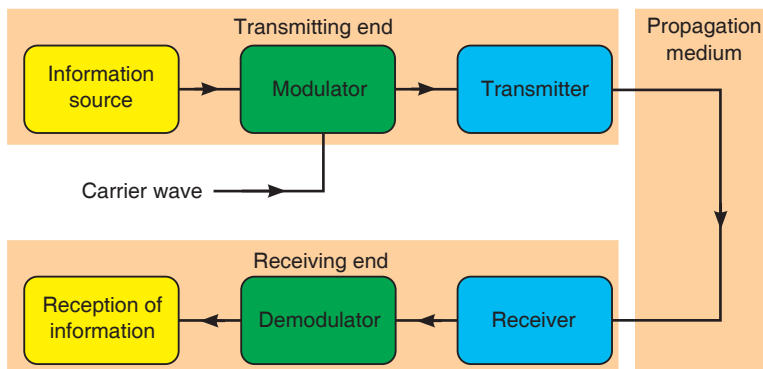

Fig. 10.1: Block diagram of information transmission

The signals from information source are added to the carrier in the modulator. The modulated signal is sent along a channel in the propagating medium by a transmitter. The propagation medium is a channel through which information is transmitted. This may be a cable or free space.

At the receiving end, the receiver may have to select and perhaps amplify the modulated signal before the demodulator extracts from it the information signal for delivery to the receptor of information.

A propagation or transmission medium can be classified as;

Linear medium: if different waves at any particular point in medium can be superposed.

Bounded medium: if it is finite in extent, otherwise unbound.

Uniform medium or homogeneous medium: if its physical properties are unchanged at different points.

Isotropic medium: if its physical properties are the same in different directions.

10.3 COMMUNICATION TERMS AND CONCEPTS

ACTIVITY 10-1: Communication terms

Complete the chart below. Give the correct term where it misses.

Term description	
1. Receiver	1. A party to whom the sender transmits the message.
2. Channel	
3. Noise	
	4. The process of sharing the messages through continuous flow of symbols.
5. Code	

1. **Communication** is the process of sharing the messages through continuous flow of symbols.
2. **Communicators** (Sender/receiver) are the participants in communication. Typically the roles reverse regularly.
3. **Message** is a single uninterrupted verbal or nonverbal utterance.
4. **Code** means a system suitable for creating/carrying messages through a specific medium.
 - encode (put into code) and
 - decode (take out of code)
5. **Channels** (verbal, nonverbal, etc.) means the specific mechanism (“pipeline”) used to transmit the message.
6. **Mode of communication** (face-to-face, television, web, phone, etc.) - form or technology of transmission — determines kind of code used.
7. **Noise** - interference with message — external (physical), internal (mental) or semantic (misunderstanding/reaction).
8. **Environment** (part of context) - is that which surrounds and provides a basis for the meaning of a message:
 - Physical (surroundings)
 - Temporal (point in time)
 - Relational (the existing relationship between communicators - friends, strangers, etc.)

- Cultural (language and behaviour of community and the communicator(s) come from)

9. **Feedback** - checks effects of messages

- positive feedback eg. “keep doing what you’re doing”
- negative feedback eg. “change what you’re doing”.

10. **Levels** (contexts) of Communication

- Intrapersonal
- Interpersonal
- Public Communication
- Mass Communication (non-interactive)
- Computer Mediated Communication (interactive)

10.4 ELEMENTS OF COMMUNICATION

ACTIVITY 10-2: Elements of Communication

Aim: To find out the elements of communication in a basic communication model.

Carefully analyse Fig. 10.2 below and describe the elements of communication available.



Fig.10-2; Communication between two people.

Communication is a two-way process that results in a shared meaning or common understanding between the sender and the receiver. An understanding of how communication works can help us to understand and

improve our communication. The basic communication model consists of five elements of communication: the sender, receiver, message, channel and feedback.

Sender

The sender is a party that plays the specific role of initiating communication. To communicate effectively, the sender must use effective verbal as well as nonverbal techniques. Such as:-

- Speaking or writing clearly.
- Organizing your points to make them easy to follow and understand.
- Maintaining eye contact.
- Using proper grammar.
- Giving accurate information.

All the above components are essential in the effectiveness of your message. One will lose the audience if it becomes aware of obvious oversights on ones part. The sender should have some understanding of who the receiver is, in order to modify the message to make it more relevant.

Receiver

The receiver means the party to whom the sender transmits the message. A receiver can be one person or an entire audience of people. In the basic communication model, the receiver is directly connected with the speaker. The receiver can also communicate verbally and nonverbally. The best way to receive a message is:-

- To listen carefully.
- Sitting up straight.
- Making eye contact.
- Don't get distracted or try to do something else while you're listening.
- Nodding and smiling as you listen.
- Demonstrate that you understand the message.

Message

The message is the most crucial element of effective communication which includes the content a sender conveys to the receiver. A message can come in many different forms, such as an oral presentation, a written document, an advertisement or just a comment. In the basic communication model, the way from one point to another represents the sender's message travelling to the receiver. The message isn't necessarily what the receiver perceive it to

be. Rather, the message is what the sender intends the message to be. The sender must not only compose the message carefully, but also evaluate the ways in which the message can be interpreted.

Channel

The channel is a medium through which a message travels from the sender to the receiver. The message travels from one point to another via a channel of communication. The channel is a physical medium stands between the sender and receiver.

Many channels or types of communication exist, such as

- The spoken word,
- Radio or television,
- An Internet site or
- Something written, like a book, letter or magazine.

Every channel of communication has its advantages and disadvantages. For example, one disadvantage of the written word, on a computer screen or in a book, is that the receiver cannot evaluate the tone of the message. For this reason, effective communicators should make written word communications clear so receivers don't rely on a specific tone of voice to convey the message accurately. The advantages of television as a channel for communication include its expansive reach to a wide audience and the sender's ability to further manipulate the message using editing and special effects.

Feedback

This describes the receiver's response or reaction to the sender's message. The receiver can transmit feedback through asking questions, making comments or just supporting the message that was delivered. Feedback helps the sender to determine how the receiver interpreted the message and how it can be improved.

10.5 TYPES OF INFORMATION AND REQUIREMENTS

Constructional/creative information: This includes all information that is used for the purpose of producing something. Before anything can be made, the originator mobilizes his intelligence, his supply of ideas, his know-how, and his inventiveness to encode his concept in a suitable way.

Operational information: All concepts having the purpose of maintaining some "industry" in the widest sense of the word are included under this kind of information. Many systems require operational information in the form of programs for proper functioning. Examples of operational information include:

- the operating system of a computer (eg. DOS programs),
- the program controlling a robot or a process computer,
- warning systems for airplanes and ships,
- the hormonal system of the body

Communication information: This is composed of all other kinds of information, eg. letters, books, phone calls, radio transmissions, bird songs and also the message of the Bible. Aspect of such information does not include the construction of a product, neither it is involved in maintaining some process. The goals are transmission of a message, spreading joy, amusement, instruction and personal confidences.

10.6 SIMPLEX TRANSMISSION

Simplex transmission is a single one-way base band transmission. Simplex transmission, as the name implies, is simple. It is also called unidirectional transmission because the signal travels in only one direction. An example of simplex transmission is the signal sent from the TV station to the home television.

Data in a simplex channel is always one way. Simplex channels are not often used because it is not possible to send back error or control signals to the transmit end.



Fig.10-3: Simplex transmission

10.7 HALF-DUPLEX COMMUNICATIONS

Half-duplex transmission is an improvement over simplex transmission because the traffic can travel in both directions. Unfortunately, the road is not wide enough to accommodate bidirectional signals simultaneously. This means that only one side can transmit at a time. Two-way radios, such as

police or emergency communications mobile radios, work with half-duplex transmissions. If people at both ends try to talk at the same time, none of the transmissions get through.

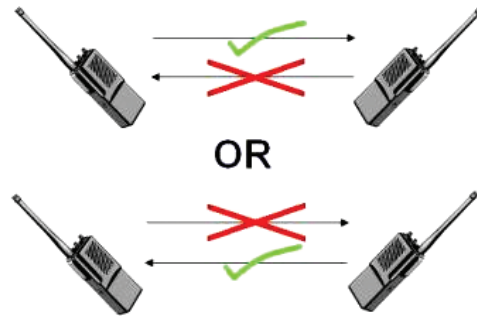

Fig. 10.4: Half duplex communication

10.8 FULL-DUPLEX COMMUNICATIONS

Full-duplex transmission operates like a two-way, two-lane street. Traffic can travel in both directions at the same time.

A land-based telephone conversation is an example of full-duplex communication. Both parties can talk at the same time, and the person talking on the other end can still be heard by the other party while they are talking. Although when both parties are talking at the same time, it might be difficult to understand what is being said.

Full-duplex networking technology increases performance because data can be sent and received at the same time. Digital subscriber line (DSL), two-way cable modem, and other broadband technologies operate in full-duplex mode. With DSL, for example, users can download data to their computer at the same time they are sending a voice message over the line.



Fig. 10.5: DSL Communication

10.9 BANDWIDTH AND SIGNAL FREQUENCY

Frequency is a parameter that determines how often the sinusoidal signal goes through a cycle. It is usually represented with the symbol f , and it has the unit hertz.

$$f = \frac{1}{T}$$

Where T is a periodic time and is measured in seconds.

The bandwidth of a composite signal is the difference between the highest and the lowest frequencies contained in that signal. It is typically measured in hertz, and may sometimes refer to passband bandwidth or baseband bandwidth, depending on context.

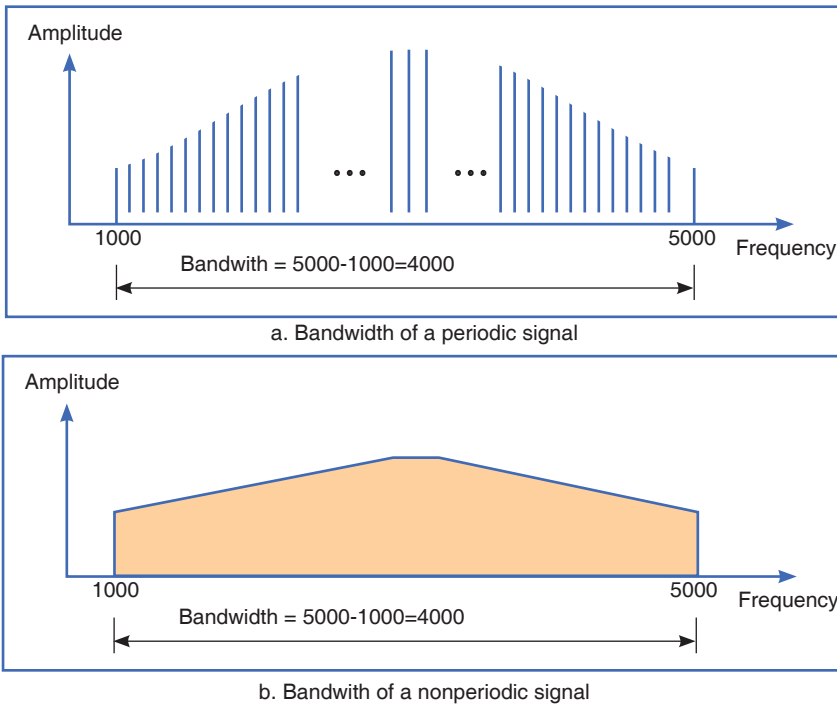

Fig. 10.6: Bandwidth and frequency

Mathematically, the bandwidth is given by;

$$BW = f_{USB} - f_{LSB}$$

Where f_{USB} and f_{LSB} stand for upper side band and lower side band respectively.

10.10 ANALOG SIGNAL SYSTEM

A system is a physical set of components that take a signal and produces a signal. In terms of engineering, the input is generally some electrical signal and the output is another electrical signal.

Analog systems operate with values that vary continuously and have no

abrupt transitions between levels. For a long time, almost all electronic systems were analog, as most things we measure in nature are analog. For example, your voice is analog; it contains an infinite number of levels and frequencies. Therefore, if you wanted a circuit to amplify your voice, an analog circuit seems a likely choice.

In Rwanda recently analog systems were replaced by digital systems that provide greater capacity of data transfer and increased reliability and security.

Example of an analog electronic system

A public address system

A **public address system (PA system)** is an electronic sound amplification and distribution system with a microphone, amplifier and loudspeakers, used to allow a person to address a large public, for example for announcements of movements at large and noisy air and rail terminals or a sports stadium.



Fig. 10.7: Public address system

10.11 ANALOG SIGNALS

Analog signal is a continuous signal that contains time varying quantities. An analog signal is a continuous wave denoted by a sine wave and may vary in signal strength (amplitude) or frequency (time). The sine wave's amplitude value can be seen as the higher and lower points of the wave, while the frequency (time) value is measured in the sine wave's physical length from left to right.

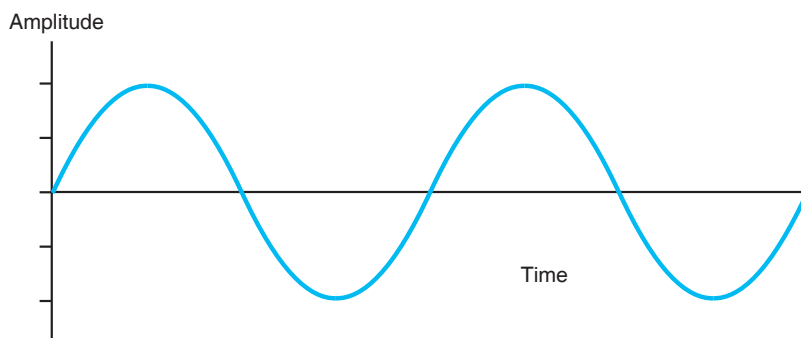

Fig. 10.8: Analog signal

Analog signal can be used to measure changes in physical phenomenon such as light, sound, pressure, or temperature. For instance, microphone can convert sound waves into analog signal. Even in digital devices, there is typically some analog component that is used to take in information from the external world which will then get translated into digital form –using analog to digital converter.

10.12 ADVANTAGES AND DISADVANTAGES OF ANALOG SIGNALS

Advantages

- Uses less bandwidth than digital sounds.
- More accurate representation of sound.
- It is the natural form of sound.
- Because of editing limitations, there is little someone can do to tinker with the sound, so what you are hearing is the original sound.

Disadvantages

- There are limitations in editing.
- Recording analog sound on tape is expensive.
- It is harder to synchronize analogous sound.
- Quality is easily lost if the tape becomes ruined.

- A tape must always be wound and rewound in order to listen to specific part of sound which can damage it.
- Analog is susceptible to clipping where the highest and lowest notes of a sound are cut out during recording.

10.13 DIGITAL SIGNALS

In electronic signal and information processing and transmission, digital technology is increasingly being used because, in various applications, digital signal transmission has many advantages over analog signal transmission. Numerous and very successful applications of digital technology include the continuously growing number of PC's, the communication network ISDN as well as the increasing use of digital control stations (Direct Digital Control: DDC).

Unlike analog technology which uses continuous signals, digital technology encodes the information into discrete signal states. When only two states are assigned per digital signal, these signals are termed binary signals. One single binary digit is termed a bit - a contraction for binary digit.

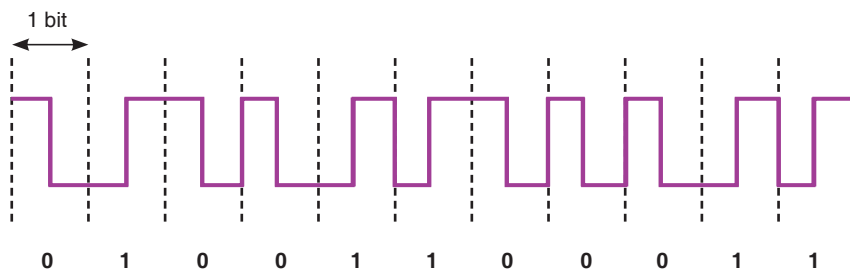

Fig. 10.9: Digital signal

10.14. ADVANTAGES OF DIGITAL TECHNOLOGY

- **More capacity from the same number of frequencies;** that is, they provide superior Spectral Efficiency. This is a result of the modulation methods used, and the fact that, in many cases more than one 'conversation' can be accommodated within a single radio channel.
- **Consistent voice clarity at low received signal levels near the edge of coverage.** The general consensus is that digital radios provide better audio quality than analog ones. With analog FM radios, the audio quality steadily declines as the received signal strength gets weaker. Digital radios however, will have a consistent audio quality throughout the full service area. The edges of the coverage area in a digital radio system are similar to those experienced with cellular telephones.
- **Data is defined in the standard.** This means data implementations

are no longer proprietary, there are a wide variety of data mechanisms and interoperability can extend into the data domain. With the accepted increase of efficiency by using data communications over voice, this will further increase the usability and effectiveness of digital radio systems.

- **Secure transmissions:** In digital technologies, data and voice can be secured using encryption without impacting voice quality using industry standard encryption techniques.

10.15 COMPARING DIGITAL AND ANALOG SIGNALS

	Analog	Digital
Signal	Analog signal is a continuous signal which represents physical measurements.	Digital signals are discrete time signals generated by digital modulation.
Waves	Denoted by sine waves	Denoted by square waves
Representation	Uses continuous range of values to represent information	Uses discrete or discontinuous values to represent information
Example	Human voice in air, analog electronic devices.	Computers, CDs, DVDs and other digital electronic devices.
Technology	Analog technology records waveforms as they are.	Samples analog waveforms into a limited set of numbers and records them.
Data transmissions	Subjected to deterioration by noise during transmission and write/read cycle.	Can be noise-immune without deterioration during transmission and write / read cycle.
Response to Noise	More likely to get affected by noise, reducing accuracy	Less affected since noise response are analog in nature
Flexibility	Analog hardware is not flexible.	Digital hardware is flexible in implementation.
Uses	Can be used in analog devices only. Best suited for audio and video transmission.	Best suited for Computing and digital electronics.
Applications	Thermometer	PCs, PDAs
Bandwidth	Analog signal processing can be done in real time and consumes less bandwidth.	There is no guarantee that digital signal processing can be done in real time and consumes more bandwidth to carry out the same information.
Memory	Stored in the form of wave signal	Stored in the form of binary bit

Power	Analog instrument draws large power	Digital instrument draws only negligible power
Cost	Low cost and portable	Cost is high and not easily portable
Impedance	Low	High order of 100 megaohm
Errors	Analog instruments usually have a scale which is cramped at lower end and give considerable observational errors.	Digital instruments are free from observational errors like parallax and approximation errors.

Principle of digital signal systems

A digital signal refers to an electrical signal that is converted into a pattern of bits. Unlike an analog signal, which is a continuous signal that contains time-varying quantities, a digital signal has a discrete value at each sampling point. The precision of the signal is determined by how many samples are recorded per unit of time. For example, the illustration of fig below shows an analog pattern (represented as the curve) alongside a digital pattern (represented as the discrete lines).

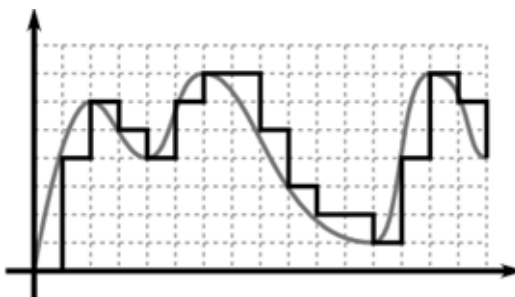

Analog pattern alongside digital pattern

A digital signal is easily represented by a computer because each sample can be defined with a series of bits that are either in the state 1 (on) or 0 (off). Digital signals can be compressed and can include additional information for error correction. A signal in which the original information is converted into a string of bits before being transmitted. A radio signal, for example, will be either on or off. Digital signals can be sent for long distances and suffer less interference than analog signals.

Boolean functions may be practically implemented by using electronic gates. The following points are important to understand.

- Electronic gates require a power supply.
- Gate INPUTS are driven by voltages having two nominal values, e.g. 0 V and 5 V representing logic 0 and logic 1 respectively.
- The OUTPUT of a gate provides two nominal values of voltage only, e.g. 0

V and 5 V representing logic 0 and logic 1 respectively. In general, there is only one output to a logic gate except in some special cases.

- There is always a time delay between an input being applied and the output responding.

Application Activity

Question on digital and analogue signal.

1. The two basic types of signals are analog and:

A. Digilog

B. Digital

C. Vetilog

D. Sine wave

2. Which of the following characterizes an analog quantity?

A. Discrete levels represent changes in a quantity.

B. Its values follow a logarithmic response curve.

C. It can be described with a finite number of steps.

D. It has a continuous set of values over a given range.

3. Which type of signal is represented by discrete values?

A. Noisy signal

B. Nonlinear

C. Analog

D. Digital

4. A data conversion system may be used to interface a digital computer system to:

A. An analog output device

B. A digital output device

C. An analog input device

D. A digital printer

10.16 LOGIC GATES

There are three basic logic gates each of which performs a basic logic function. They are called NOT, AND and OR. All other logic functions can ultimately be derived from combinations of these three. For each of the three basic logic gates a summary is given including the logic symbol, the corresponding truth table and the Boolean expression.

AND gate

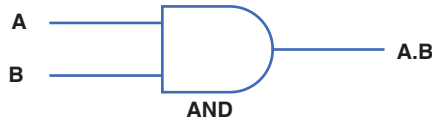

Fig. 10.10: AND gate

The AND gate is an electronic circuit that gives a high output (1) only if all its inputs are high. A dot (.) is used to show the AND operation i.e. A.B. It can also be written as AB.

2 input AND gate		
A	B	AB
0	0	0
0	1	0
1	0	0
1	1	1

OR gate

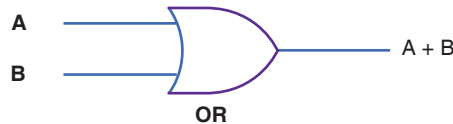

Fig. 10.11: OR gate

The OR gate is an electronic circuit that gives a high output (1) if one or more of its inputs are high. A plus (+) is used to show the OR operation.

2 input OR gate		
A	B	AB
0	0	0
0	1	1
1	0	1
1	1	1

NOT gate

nand gate

- this a not-and gate which is equal to an and gate followed by a not gate
- the inputs of all nand gates are true if any of the input are false
- the symbol is an and gate with a small circle on the output. The small circle represents inversion

Two input nand gate		
A	B	\overline{AB}
0	0	1
0	1	1
1	0	1
1	1	0

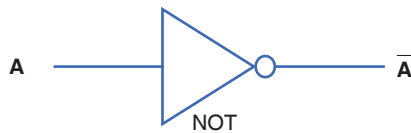

Fig. 10.12: NOT gate

The NOT gate is an electronic circuit that produces an inverted version of the input at its output. It is also known as an inverter. If the input variable is A, the inverted output is known as NOT A. This is also shown as A', or \overline{A} , as shown at the outputs.

NOT gate	
A	\overline{A}
0	1
1	0

Another useful gate used in the digital logic circuits is EX–OR gate.

EXOR gate

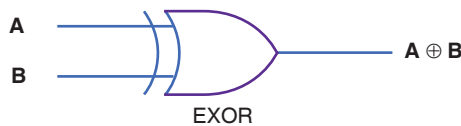

Fig. 10.13: EX–OR gate

The 'Exclusive-OR' gate is a circuit which will give a high output if either, but not both, of its two inputs are high. An encircled plus sign (\oplus) is used to show the EX–OR operation.

2 input EX-OR gate		
A	B	$A \oplus B$
0	0	0
0	1	1
1	0	1
1	1	0

nand gate

- this a not-and gate which is equal to an and gate followed by a not gate
- the inputs of all nand gates are true if any of the input are false
- the symbol is an and gate with a small circle on the output. The small circle represents inversion

Two input nand gate		
A	B	\overline{AB}
0	0	1
0	1	1
1	0	1
1	1	0

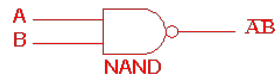

norgate

- This is a NOT-OR gate which is equal to an OR gate followed by a NOT gate.
- The outputs of all NOR gates are low if any of the inputs are high.
- The symbol of is an or gate with a small circle on the output. The small circle represent the inversion

Two input nand gate		
A	B	$\overline{A+B}$
0	0	1
0	1	0
1	0	0
1	1	0

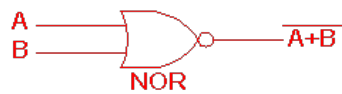

EXAMPLE

Construct a truth table of the following logic circuit

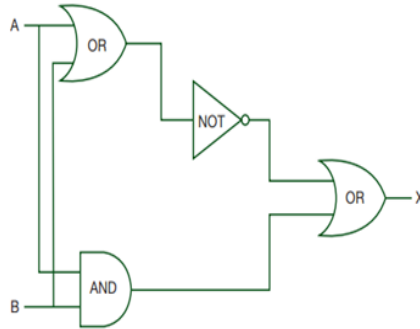

ANSWER

A	B	$C = (A \oplus B)$	$D = (\overline{A \oplus B})$	$E = (A \odot B)$	$X = (E \oplus D)$
0	0	0	1	0	1
1	0	1	0	0	0
0	1	1	0	0	0
1	1	0	1	1	1

Application Activity

1. Produce a truth table from the following logic circuit (network)

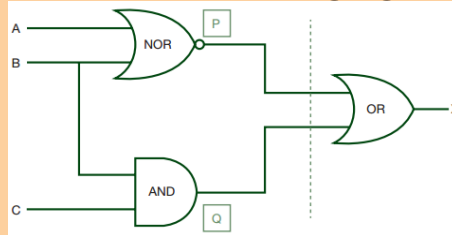

Fig. 10.14: Logic circuit 1

2. For the logic circuits below produce the truth tables. Remember, if there are 2 inputs then there will be 4 outputs; if there are 3 inputs then there will be 8 possible outputs. Use the idea shown in the logic circuits discussed in section 10.6.

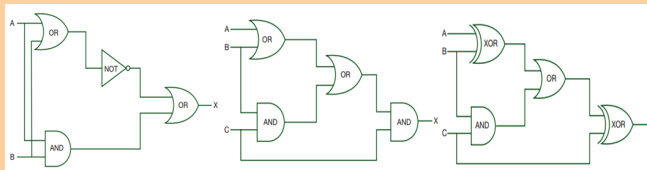

Fig. 10.15: Logic circuit 2

● END OF UNIT ASSESSMENT ●

1. There has been a move to advise people to change from using analog systems to start using digital systems especially here in Rwanda. Do you support this move? If yes, why? If no why not?
2. Produce a truth table from the following logic circuit (network).

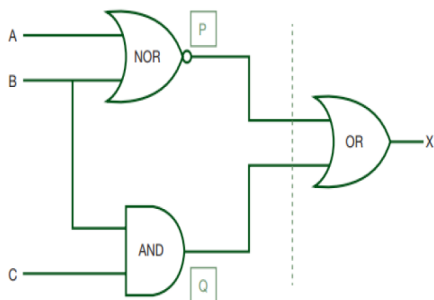

Fig. 10.14: Logic circuit 1

3. For the logic circuits below produce the truth tables. Remember, if there are 2 inputs then there will be 4 outputs; if there are 3 inputs then there will be 8 possible outputs. Use the idea shown in the logic circuits discussed in section 10.6.

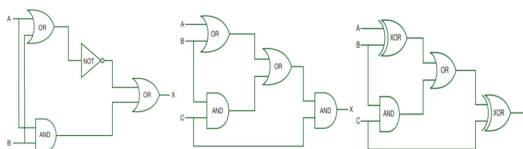

Fig. 10.15: Logic circuit 2

UNIT SUMMARY

Information transmission in a communication system

The signals from information source are added to the carrier in the modulator. The modulated signal is sent along a channel in the propagating medium by a transmitter. The propagation medium is a channel through which information is transmitted. This may be a cable or a free space.

Communication Terms and Concepts

- Communication
- Communicator
- Message
- Medium

- Noise
- Environment
- Feedback
- Levels

Elements of communication

- Sender
- Receiver
- Message
- Channel
- Feedback

Types of information and requirements

- Constructional/creative information
- Operational information
- Communicational information

Simplex transmission

Simplex transmission is a single one-way base band transmission. Simplex channels are not often used because it is not possible to send back error or control signals to the transmit end.

Half-duplex communications

Half-duplex transmission is an improvement over simplex because the traffic can travel in both directions. Full-duplex networking technology increases performance because data can be sent and received at the same time.

Bandwidth and signal Frequency

The bandwidth of a composite signal is the difference between the highest and the lowest frequencies contained in that signal.

Mathematically, the bandwidth is given by;

$$BW = f_{USB} - f_{LSB}$$

Where f_{USB} and f_{LSB} stand for upper side band and lower side band respectively.

- Medium
- Noise
- Environment
- Feedback
- Levels

Elements of communication

Analogue signal system

Analogue systems operate with values that vary continuously and have no abrupt transitions between levels.

Analog signals

Analog signal is a continuous signal that contains time varying quantities. An analog signal is a continuous wave denoted by a sine wave and may vary in signal strength (amplitude) or frequency (time).

Digital signals

Unlike analog technology which uses continuous signals, digital technology encodes the information into discrete signal states. Numerous and very successful applications of digital technology include the continuously growing number of PC's, the communication net work ISDN as well as the increasing use of digital control stations (Direct Digital Control: DDC).

Advantages of digital technology

- More capacity from the same number of frequencies.
- Consistent voice clarity at low received signal levels near the edge of coverage.
- Data is defined in the standard.
- Secure transmissions.

Logic gates

There are three basic logic gates each of which performs a basic logic function, they are called NOT, AND and OR. All other logic functions can ultimately be derived from combinations of these three.

**UNIT
11**

MOBILE PHONE AND RADIO COMMUNICATION



Key unit competence: By the end of the unit I should be able to distinguish mobile phone system from radio system of communication.

Unit Objectives:

By the end of this unit I will be able to;

- ◇ explain the concept and principles of cellular radio network.
- ◇ explain the need for cellular system in modern mobile communication.

Introductory Activity

The figure below shows how network for a certain telecommunications company in Rwanda. Study it carefully and answer the following questions.

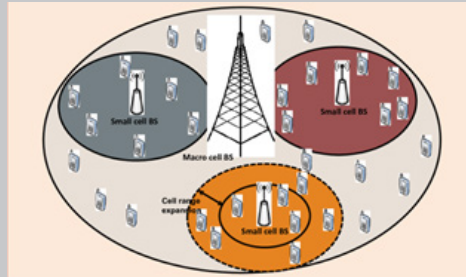

Network transmission

- How many cells can you see in the figure above?
- Identify different masts shown on the figure.
- In regard to the figure, what is the importance of masts in those different cells?
- Why do you think in transmission of network, the targeted area is divided into small portions?
- Compare the number of cells that should be allocated for urban areas to those for rural areas.

11.0 INTRODUCTION

The communication is the way of expressing our thoughts. In other words, communication means sending or receiving message from one end to other. We can express our feelings to others by speaking, writing or silent indications. All living beings communicate to each other in different ways. They have different types of voices and they understand meaning of voice of their species. Human has also developed his dialect to communicate with others. We learn different languages to understand meaning of other's dialects.

Devices used to talk, or to send message one end to other, or from one person to other are called means of communication. Means of Communication are the most necessary part of modern lifestyle. In modern age, there are many types of means of communications like newspaper, Telephone, Mobile, TV, Internet etc. They play very important role in our daily life activities.

This concept is closely related to the concepts of blood circulation (in Biology and Medicine), transport networks, transmission of information etc.

11.1 CONCEPTS OF TRANSMISSION SYSTEM

In telecommunication, a communication system is a collection of individual communication networks, transmission systems, relay stations tributary stations and Data Terminal Equipment (DTE) usually capable of interconnection and interoperation to form an integrated whole.

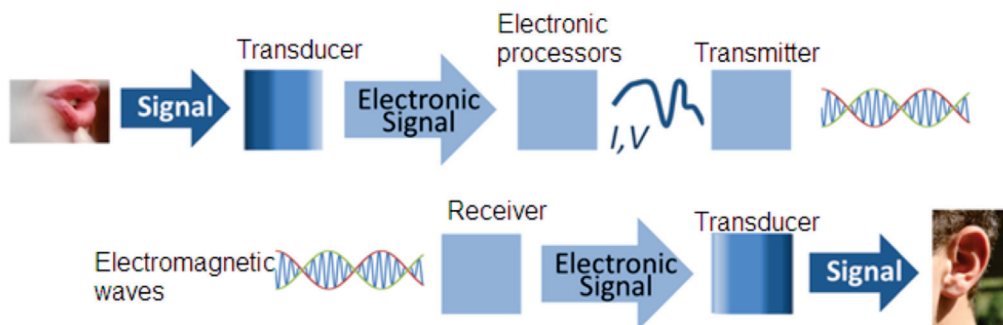

Fig. 11-1; Basic communication system

In the transmission section, first of all, the source generated information is fed to the input transducer, which converts energy of one form to another form, usually in electrical form. This electrical signal or base band signal is sent to the transmitter.

Transmitter:

Transmitter modifies the information signal for efficient transmission. It modulates the information signal with a high frequency carrier. After processing the signal transmitter transmits the signal, through channel to the receiver.

Channel:

Channel, media or path implies the medium through which the message travels from the transmitter to the receiver. A channel acts partly as a filter to attenuate the signal and distorts its waveform. The signal attenuation increases with the length of the channel. There are different types of channels for different communication systems, such as wire, coaxial cable, wave-guide, optical fiber or radio link through which transmitter output is sent.

Receiver:

Receiver reprocesses the signal received from the channel by undoing the signal modifications made at the transmitter and the channel. The receiver output is fed to the output transducer, which converts the electrical signal to its original form. By this way, the signal reached to its destination, to which the message is communicated.

Digital communication:

Digital communication system exchange (both transmit and receive) information to /from digital sources.

A digital (information) source produces a finite set of possible messages. Typewriter is a good example of a digital source. There is a finite no. of characters that can be emitted by this source.

Analog communication:

Analog communication system exchange (both transmit and receive) information to /from analog sources. A microphone is a good example of an analog source. An analog information source produces messages that are defined on a continuum.

Why do we use digital not analog?

Digital communication has a number of advantages:

- Relatively inexpensive digital circuits may be used.
- Digital systems are relatively easy to design and can be fabricated on IC chips.
- Information storage is easy.
- Operation can be programmable to update with newly upcoming technologies.
- Privacy is preserved by using data encryption.
- Greater dynamic range is possible.
- Data from voice, video and data sources may be merged and transmitted over a common digital transmission system. i.e. it is easy to multiplex several digital signals.
- In long distance communication system, noise does not accumulate from repeater to repeater.
- Error detection and correction schemes can be employed by using coding techniques.

Limitations of Digital communication system

- Generally, more bandwidth is required than that for analog system.
- Synchronization is required, which calls for more sophisticated device and costs more.

A/D converter

We use analog to digital converter, to convert analog signals to digital signals.

A/D conversion has three steps:

(a) Sampling

In this process, Continuous-time signal is converted to Discrete-time signal obtained by taking samples of the continuous-time signal at discrete-time instants.

(b) Quantization

In this process, a Discrete-time Continuous-valued signal is converted into a Discrete-time Discrete-valued (digital) signal. The sampled signal is rounded off to the fourth nearest value which is permitted for transmission by the system. The process of rounding off is called Quantization, while the possible levels permitted for transmission are called Quantizing levels.

(c) Coding

In the coding process, each discrete value is represented by 8-bit binary sequence e.g. 10010101. It consists of combinations of 0 and 1.

11.2 PRINCIPLE OF CELLULAR RADIO

The cellular concept was a major breakthrough in solving the problem of spectral congestion and user capacity. It offered very high capacity output in a limited spectrum allocation without any major technological changes. The cellular concept is a system-level idea which calls for replacing a single, high power transmitter (large cell) with many low power transmitters (small cells), each providing coverage to only a small portion of the service area.

Each base station is allocated a portion of the total number of channels available to the entire system, and nearby base stations are assigned different groups of channels so that all the available channels are assigned a relatively small number of neighbouring base stations. Neighbouring base stations are assigned different groups of channels so that the interference between base stations (and the mobile users under their control) is minimized.

By systematically spacing base stations and their channel groups throughout a market, the available channels are distributed throughout the geographic region and may be reused as many times as necessary so long as the interference between co-channel stations is kept below acceptable levels.

11.3 STRUCTURE OF CELLULAR NETWORK

An overall cellular network contains a number of different elements from the **base transceiver station** (BTS) itself with its antenna back through

a **base station controller (BSC)**, and a **mobile switching centre (MSC)** to the location registers (HLR and VLR) and the link to the public switched telephone network (PSTN).

Of the units within the cellular network, the BTS provides the direct communication with the mobile phones. There may be a small number of base stations linked to a base station controller. This unit acts as a small centre to route calls to the required base station, and it also makes some decisions about which base station is the best suited for a particular call. The links between the BTS and the BSC may use either land lines or even microwave links. Often the BTS antenna towers also support a small microwave dish antenna used for the link to the BSC. The BSC is often co-located with a BTS.

The BSC interfaces with the mobile switching centre. This makes more widespread choices about the routing of calls and interfaces to the land line based PSTN as well as the location registers.

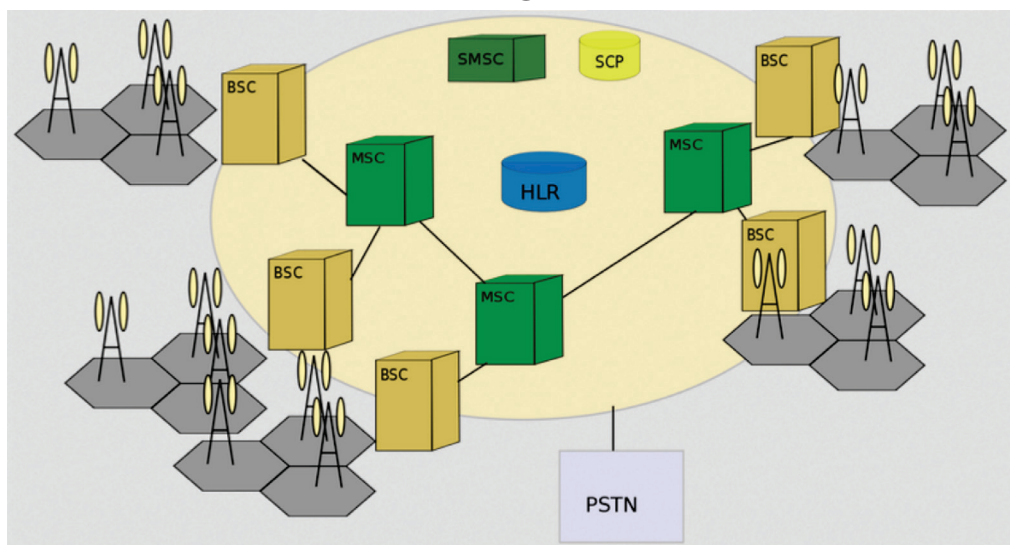

Fig.11-2; Structure of cellular network

11.4 PRINCIPLE OF CELLULAR NETWORK

Increase in demand and the poor quality of existing service led mobile service providers to research ways to improve the quality of service and to support more users in their systems. Because the amount of frequency spectrum available for mobile cellular use was limited, efficient use of the required frequencies was needed for mobile cellular coverage. In modern cellular telephony, rural and urban regions are divided into areas according to specific provisioning guidelines.

Deployment parameters, such as amount of cell-splitting and cell sizes, are determined by engineers experienced in cellular system architecture. Provisioning for each region is planned according to an engineering plan that includes cells, clusters, frequency reuse, and handovers.

Cells

A cell is the basic geographic unit of a cellular system. The term cellular comes from the honeycomb shape of the areas into which a coverage region is divided. Cells are base stations transmitting over small geographic areas that are represented as hexagons. Each cell size varies depending on the landscape. Because of constraints imposed by natural terrain and man-made structures, the true shape of cells is not a perfect hexagon

Clusters

A cluster is a group of cells. No channels are reused within a cluster.

Fig.11-2 illustrates a seven-cell cluster. In clustering, all the available frequencies are used once and only once. As shown on Fig.11-3, each cell has a base station and any mobile user moving remains connected due to hand-offs between the stations.

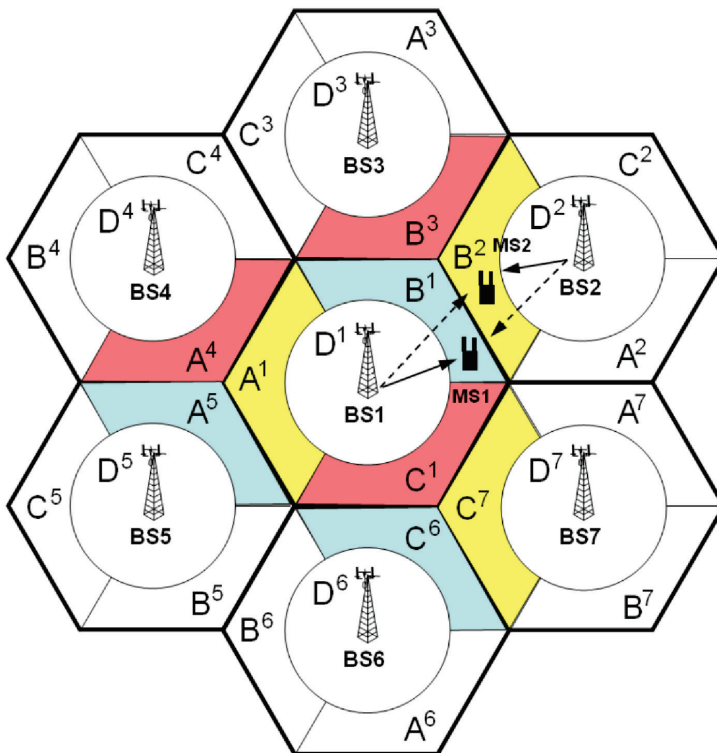

Fig.11-3: Cluster

Frequency Reuse

Because only a small number of radio channel frequencies were available for mobile systems, engineers had to find a way to reuse radio channels in order to carry more than one conversation at a time. The solution was called frequency planning or frequency reuse. Frequency reuse was implemented by restructuring the mobile telephone system architecture into the cellular concept.

The concept of frequency reuse is based on assigning to each cell a group of radio channels used within a small geographic area. Cells are assigned a group of channels that is completely different from neighbouring cells. The coverage area of cells are called the footprint. This footprint is limited by a boundary so that the same group of channels can be used in different cells that are far enough away from each other so that their frequencies do not interfere.

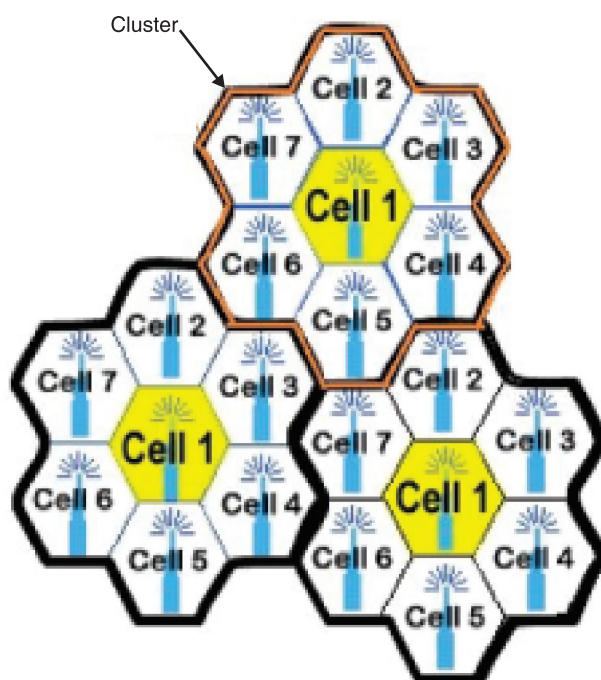

Fig.11.4; Frequency reuse.

Cells with the same number have the same set of frequencies. Here, because the number of available frequencies is 7, the frequency reuse factor is $1/7$. That is, each cell is using $1/7$ of available cellular channels.

Cell Splitting

Unfortunately, economic considerations made the concept of creating full systems with many small areas impractical. To overcome this difficulty,

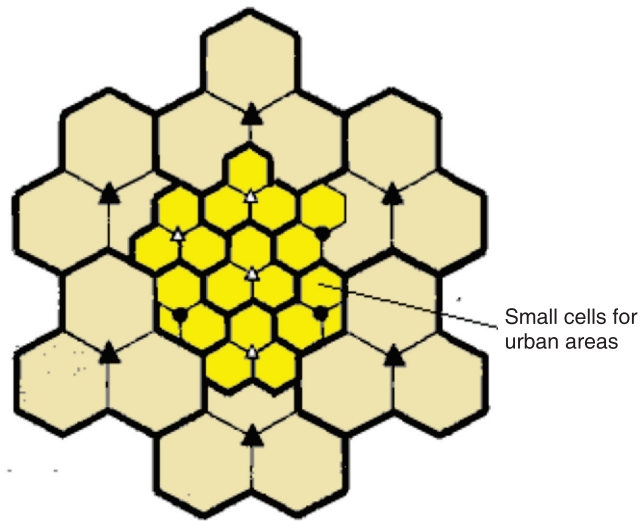

Fig.11.5; Cell splitting

system operators developed the idea of cell splitting. As a service area becomes full of users, this approach is used to split a single area into smaller ones. In this way, urban centers can be split into as many areas as necessary in order to provide acceptable service levels in heavy-traffic regions, while larger, less expensive cells can be used to cover remote rural regions.

Handoff

The final obstacle in the development of the cellular network involved the problem created when a mobile subscriber travelled from one cell to another during a call. As adjacent areas do not use the same radio channels, a call must either be dropped or transferred from one radio channel to another when a user crosses the line between adjacent cells. Because dropping the call is unacceptable, the process of handoff was created. Handoff occurs when the mobile telephone network automatically transfers a call from radio channel to radio channel as a mobile crosses adjacent cells.



Fig. 11.6; Handoff

During a call, two parties are on one voice channel. When the mobile unit moves out of the coverage area of a given cell site, the reception becomes weak. At this point, the cell site in use requests a handoff. The system switches the call to a stronger-frequency channel in a new site without interrupting the call or alerting the user. The call continues as long as the user is talking, and the user does not notice the handoff at all.

11.5 MOBILE COMMUNICATION SYSTEMS

Mobile communication systems have become one of the hottest areas in the field of telecommunications and it is predicted that within the next decade, a considerable number of connections will become partially or completely wireless. Rapid development of the Internet with its new services and applications has created fresh challenges for the further development of mobile communication systems.

We can say that mobile communication system is a high capacity communication system arranged to establish and maintain continuity of communication paths to mobile stations passing from the coverage of one radio transmitter into the coverage of another radio transmitter. A control center determines mobile station locations and enables a switching center to control dual access trunk circuitry to transfer an existing mobile station communication path from a formerly occupied cell to a new cell location. The switching center subsequently enables the dual access trunk to release the call connection to the formerly occupied cell.

ACTIVITY 11-1: The Concept of Communication

Aim: this activity aim at understanding the concept of communication.

a) The figure below shows the Amahoro village. Explain all the possible ways of communication according to the infrastructure shown.



b) Use the equipment below and create 2 communication stories. You must use at least 4 equipments.



11.6 RADIO TRANSMISSION (AM, FM, PM)

Application Activity



Radio receiver

While listening to radio on one of the evening, Mukagatsinzi heard that the tuned channel was on FM at 100.7 MHz. But her radio works efficiently when she pulls up the antenna.

- f. What do you think is the significance of the antenna on her radio?
- g. Hoping you have ever used/played a radio. Where do you think the information/sound from the radio come from?
- h. Explain the mode of transmission of information as suggested in b) above to the receiving radio.
- i. While going to sleep, her radio fell down and the speaker got problems. Do you think she was able to listen to late night programs on the same channel?
- j. As indicated on the radio, what does FM, MW, and SW mean?

Modulation is a technique used for encoding information into a RF channel. Typically the process of modulation combines an information signal with a carrier signal to create a new composite signal that can be transmitted over a wireless link. In theory, a message signal can be directly sent into space to a receiver by simply powering an antenna with the message signal. However, message signals typically don't have a high enough bandwidth to make efficient direct propagation. In order to efficiently transmit data, the lower frequency data must be modulated onto a higher frequency wave.

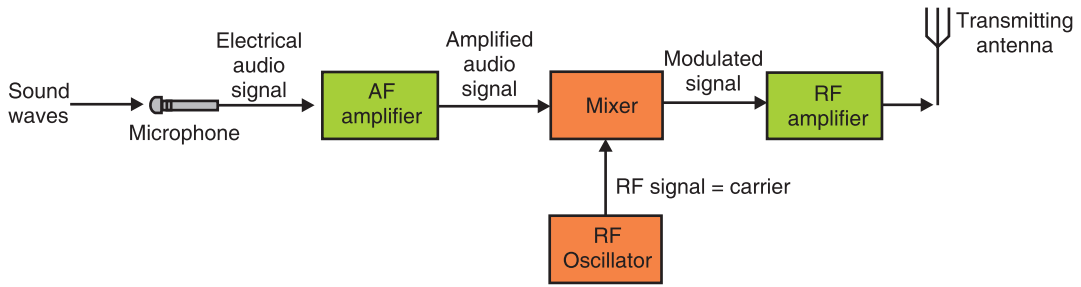

Fig.11-7; Signal transmission

The high frequency wave acts as a carrier that transmits the data through space to the receiver where the composite wave is demodulated and the data is recovered. There are a few general types of modulation; Frequency Modulation (FM), Phase Modulation (PM) and Amplitude modulation (AM).

Frequency modulation (FM)

This is a kind of modulation which is used in every high broadcasts. The frequency of the carrier is altered at a rate equal to the frequency of the audio frequency but the amplitude remains constant.

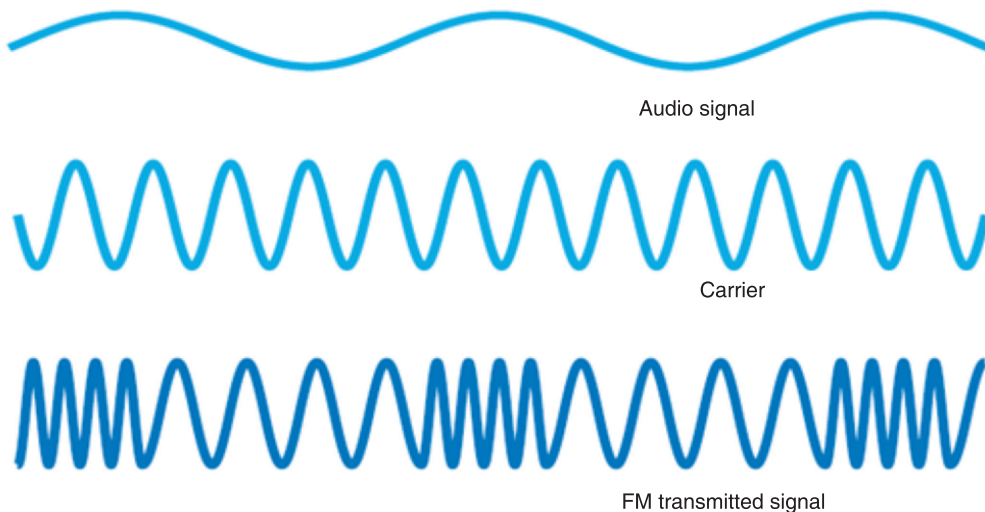

Fig.11-8; Frequency modulation

Frequency modulation is widely used for FM radio broadcasting. It is also used in telemetry, radar, seismic prospecting monitoring newborns (for seizures via Electroencephalography), two-way radio systems, music synthesis, magnetic tape-recording systems and some video-transmission systems. In radio transmission, an advantage of frequency modulation is that it has a larger signal-to-noise ratio and therefore rejects radio frequency interference better than an equal power amplitude modulation (AM) signal. For this reason, most music is broadcast over FM radio.

Amplitude modulation (AM)

In amplitude modulation, the information signal is used to vary the amplitude of the carrier so that it follows the wave shape of information signal. Here, before the information is transmitted, it is first mixed to a carrier signal so that it can be transmitted over a long distance with low attenuation.

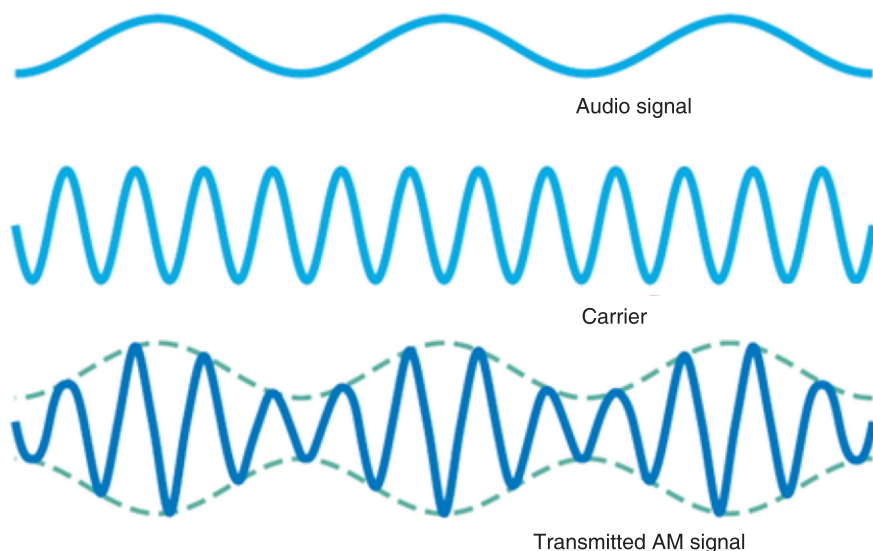
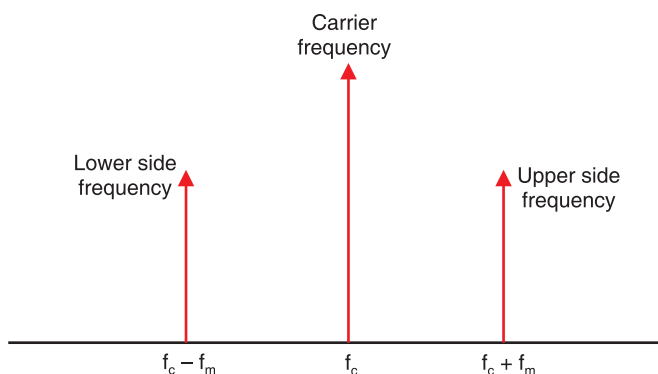

Fig.11-9; Amplitude modulation

The modulated signal contains other frequencies called side frequencies which are created on either sides of the carrier. If the carrier frequency is f_c and modulated frequency is f_m , two new frequencies are $f_c - f_m$ and $f_c + f_m$.



Band width, $BW = (f_c + f_m) - (f_c - f_m) = 2f_m$

Fig.11-10; Side frequencies of amplitude modulation

Phase modulation (PM)

Phase modulation is a form of modulation that encodes information as variations in the instantaneous phase of the carrier wave. It is widely

used for transmitting radio waves and is an integral part of many digital transmission coding schemes that underlie a wide range of technologies like WiFi, GSM and satellite television. In this type of modulation, the amplitude and frequency of the carrier signal remains unchanged after PM. The modulating signal is mapped to the carrier signal in the form of variations in the instantaneous phase of the carrier signal.

Phase modulation is closely related to frequency modulation and is often used as intermediate step to achieve FM.

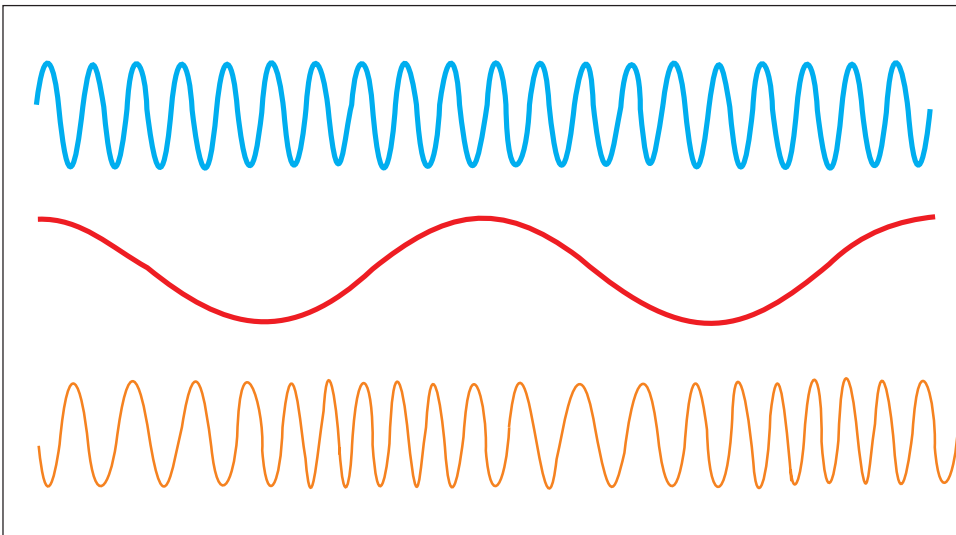

Fig.11-11; Phase modulation

11.7 POST, TELEGRAPH AND TELEPHONE (PTT)

A postal, telegraph and telephone service (or PTT) is a government agency responsible for postal mail, telegraph and telephone services. Such monopolies existed in many countries, though not in North America or Japan. Many PTTs have been partially or completely privatized in recent years. In some of those privatizations, the PTT was renamed completely, whereas in others, the name of the privatized corporation has been only slightly modified.

Postal services transport mail and small packages to destinations around the world, and they are mostly public corporations. However, there has been increased privatization of postal operators in the past 20 years, and government restrictions on private postal services have eased. Postal authorities are often also involved in telecommunications, logistics, financial services and other business areas.

Rwanda is part of the Universal Postal Union, which recommends a maximum of 9,000 people per one post office branch. The ‘iPosita Rwanda’

is the company responsible for postal service in Rwanda.

A **telegraph** is a communication system in which information is transmitted over a wire through a series of electrical current pulses, usually in the form of Morse code. The basic components include a source of direct current, a length of wire or cable, and a current-indicating device such as a relay, buzzer or light bulb.

Telephony is the technology associated with the electronic transmission of voice, fax, or other information between distant parties using systems historically associated with the telephone, a handheld device containing both a speaker or transmitter and a receiver. With the arrival of computers and the transmission of digital information over telephone systems and the use of radio to transmit telephone signals, the distinction between telephony and telecommunication has become difficult.

ACTIVITY 11-2: Structure of Communication Networks

Aim: The purpose of this activity is to give the real structure of communication network and the terms used.

Procedure: Use the following clues to fill the puzzle. The sentences to help in filling the puzzle are also given below.

ANTENNA, CAMERA , CELLULAR, FAX, FILM, HEADPHONE, KEYBOARD, LENS, MICROPHONE, PEN, PLUG, PRINTER, RADIO, SATELLITE, SPEAKER, TELEPHONE, TELEVISION, TRIPOD, TURNTABLE, VIDEO.

ACROSS:

4. I'm out of my office. I'm calling you on my cellular telephone.
8. The signal bounces off a satellite high up in outer space.
10. The needs a new link cartridge.
13. The makes his voice sound much louder.
16. The sound from the radio can out of a
17. I have the car tuned to my favorite station.
18. I used a to write a letter.
20. I type on my computer

DOWN:

1. You have to it in before it will work.
2. I bought a new for my camera.
3. On the airplane everyone listened to the movie through
4. The on my car helps distant radio stations come in more clearly.
5. My favorite Channel is the one that carries Oprah.
6. What is your number? I'll call you tomorrow.
7. That was directed by Steven Spielberg
8. You play vinyl records on a
9. He took photographs of their vacation with his digital
10. The band shot a of their latest song.
- 11 is short for facsimile.
12. The camera was perched on a

END OF UNIT ASSESSMENT

1. What do you understand by the term Modulation.
2. Explain the meaning of Amplitude Modulation.
3. Explain the different types of analog modulation.
4. In modern system, Modulation very important while transmitting signals. Discuss why modulation should be done in transmission of signals and information.
5. Discuss the objectives that are achieved when modulation is done.
6. Explain the meaning of frequency modulation.

UNIT SUMMARY

Concepts of transmission system

In telecommunication, a communication system is a collection of individual communication networks, transmission systems, relay stations, tributary stations, and data terminal equipment (DTE) usually capable of interconnection and interoperation to form an integrated whole.

Principle of cellular radio

The cellular concept is a major breakthrough in solving the problem of spectral congestion and user capacity. It involves dividing the area into small parts called cells. The neighbouring base stations are assigned

different groups of channels so that the interference between base stations (and the mobile users under their control) is minimized. It offers very high capacity in a limited spectrum allocation without any major technological changes.

Structure of cellular network

An overall cellular network contains a number of different elements from the base transceiver station (BTS) itself with its antenna back through a base station controller (BSC) and a mobile switching centre (MSC) to the location registers (HLR and VLR) and the link to the public switched telephone network (PSTN).

The BSC is often co-located with a BTS. The BSC interfaces with the mobile switching centre. This makes more widespread choices about the routing of calls and interfaces to the land line based PSTN as well as the HLR and VLR.

Principle of cellular network

Because the amount of frequency spectrum available for mobile cellular use was limited, efficient use of the required frequencies was needed for mobile cellular coverage. In modern cellular telephony, rural and urban regions are divided into areas according to specific provisioning guidelines.

Modulation techniques

Modulation is a technique used for encoding information into a RF channel. There are a few general types of modulation; Frequency Modulation (FM), Phase Modulation (PM), and Amplitude modulation (AM).

UNIT 12

RELATIVITY CONCEPTS AND POSTULATES OF SPECIAL RELATIVITY

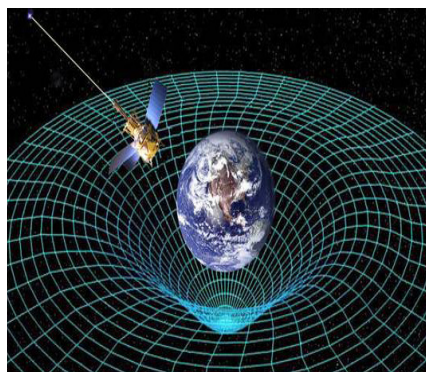

Key unit competence: By the end of the unit, I be able to analyse Relativity Concepts and postulates of special relativity.

Unit Objectives:

By the end of this unit I will be able to;

- ◇ Explain the concept of general and special relativity.
- ◇ Explain the concept of the frames of reference and apply it in other theories.

Introductory Activity

On the first day of traveling in a car, Shyaka observed trees, stones, mountains and all stationary saw them moving in the direction where the car was coming from.

- a. Were the trees, stones and mountains actually moving?
- b. If No, why did Shyaka see them moving?
- c. As Shyaka and friends in the same car tried to take over another speeding vehicle that was travelling in the same direction with the same speed, Shyaka observed that the car they were trying to overtake seemed to be stationary. Explain the cause of this effect.

12.0 INTRODUCTION

The general theory of relativity developed in the early 20th century, originally attempted to account for certain anomalies in the concept of relative motion. But it has developed into one of the most important basic concepts in physical science. The theory of relativity, developed primarily by German American physicist Albert Einstein, is the basis for later demonstration by physicists of the essential unity of matter and energy of space and time of gravity and acceleration.

12.1 DEFINITION OF RELATIVITY

This is a theory developed by Albert Einstein which says that anything except light moving with respect to the time and space depends on the position and movement of the observer. Einstein's special theory of relativity (special relativity) is all about what's relative and what's absolute about time, space and motion.

The theory states that the laws of motion are the same for all inertial (non-accelerating) frames of reference and that the speed of light (in a vacuum) is the same for all inertial reference frames. This leads to the equivalence of mass and energy, time dilation, and length contraction.

Special relativity requires us to think of space and time as inextricably linked. All our measurements of distance and time depend on the motion of the observer. The effects of time dilation and length contraction are only observed at very high speeds (close to the speed of light).

Thus, in Physics, Relativity refers to Einstein's theory that time and space are not absolute. OR, Anything except light moves with respect to time and space depends on the position and movement of someone who is watching.

12.2 CONCEPT OF SPACE, TIME AND MASS

Time Dilation

Time dilation is the phenomenon where two objects, moving with respect to each other (or even just a different intensity of gravitational field from each other) experience different rates of time flow.

Time dilation becomes most apparent when one of the objects is moving at nearly the speed of light, but it manifests at even slower speeds. Here are just a few ways we know time dilation actually takes place:

- Clocks in airplanes tick at different rates from clocks on the ground.
- Putting a clock on a mountain (thus elevating it, but keeping it stationary relative to the ground-based clock) results in slightly different rates.

- The Global Positioning System (GPS) has to adjust for time dilation. Ground-based devices have to communicate with satellites. To work, they have to be programmed to compensate for the time differences based on their speeds and gravitational influences.

Let's construct a light beam clock. It consists of two mirrors, one at a distance D above the other. At $t = 0$, we launch a photon of light upwards from the bottom of the mirror. It reflects from the top mirror and returns to its starting position, use c as the speed of the photon;

$$t_0 = \frac{2D}{c} \quad \text{..... Equation 12-1}$$

[Distance up and down ($2D$) divided by the speed of light.]

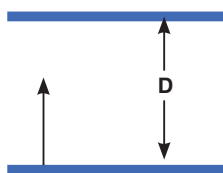

Fig. 12.1. Two mirrors, one at a distance D above the other.

This is the time for one tick of our clock. At least this shows how it seems to someone at rest with respect to the clock. But how does this appear to an observer watching us and our clock moves by at constant velocity v ? This observer sees the events as pictured below.

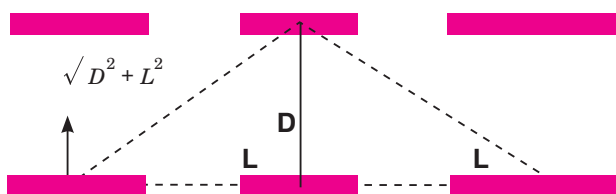

Fig. 12.2. When the photon hits the top mirror and the whole clock has moved a distance L to the right.

First, the photon is released. When the photon hits the top mirror, the whole clock has moved a distance L to the right. Thus, the photon travelled a longer distance $\sqrt{D^2 + L^2}$ as seen by this other observer. When it returns to the bottom mirror, it has travelled a distance $2\sqrt{D^2 + L^2}$ still at speed c (recall all observers measure this same speed). Thus, Δt (the time for 1 tick according to the new observer)

$$t = \frac{2\sqrt{D^2 + L^2}}{c} \quad \text{.....Equation 12-2}$$

Now, the clock is seen as moving at velocity v by our new observer.

$$2L = vt$$

$$4L^2 = v^2t^2$$

Solve for t from equation 12-2

$$t = \frac{2\sqrt{D^2 + L^2}}{c}$$

So

$$c^2t^2 = 4(D^2 + L^2)$$

Substituting in the above equation $4L^2 = v^2t^2$, we have

$$c^2t^2 = 4D^2 + v^2t^2$$

\Rightarrow

$$4D^2 = c^2t^2 - v^2t^2$$

\Rightarrow

$$t^2 = \frac{4D^2}{c^2 - v^2} = \frac{4D^2/c^2}{1 - v^2/c^2}$$

But

$$t_0 = \frac{2D}{c} \text{ [from equation (12.1)]}$$

so

$$t_0^2 = \frac{4D^2}{c^2} \text{ and we find that}$$

$$t^2 = \frac{t_0^2}{1 - v^2/c^2}$$

\Rightarrow

$$t = \frac{t_0}{\sqrt{1 - v^2/c^2}} \quad \text{.....Equation 12-3}$$

$$t = \gamma t_0 \quad \text{.....Equation 12-4}$$

where

$$\gamma = \frac{1}{\sqrt{1 - v^2/c^2}} \quad \text{.....Equation 12-5}$$

Since nothing can travel faster than light, therefore, $\gamma \geq 1$ and it appears to the observer who watches the clock go by at velocity v that it takes longer to tick ($\Delta t > \Delta t_0$) or runs slowly compared to his own clock. This is called time dilation and is a property of time, not just our unusual clock.

EXAMPLE 12.1

An astronaut travels to a distant planet with a speed of $0.5c$. According to his clock, the trip takes one year.

- How long does the trip appear to take to an observer on the earth?
- How fast should the astronaut travel so that the travel time appears two years to the observer on the earth?

Solutions

- The time measured in the spacecraft is the proper time since the clocks in the spacecraft are at rest with respect to the astronaut. So,

$$\Delta t = \frac{\Delta t_p}{\sqrt{1 - v^2/c^2}} = \frac{1 \text{ yr}}{\sqrt{1 - (0.5)^2}} = 1.15 \text{ yr}$$

$$(b) \quad \Delta t = 2\Delta t_p = \Delta t = \frac{\Delta t_p}{\sqrt{1-v^2/c^2}}$$

$$\sqrt{1-v^2/c^2} = 1/2$$

$$\Rightarrow 1 - v^2/c^2 = 1/4$$

$$v = 0.866c$$

Length Contraction

If we turn our light beam clock to face in the direction of motion, time dilation implies length contraction. If the observer at rest with respect to the clock (now a ruler) says it has proper length L_0 , then an observer on the earth watching him and his clock/ruler by velocity v sees the ruler having length L . Objects look shorter (they are contracted) in the direction of motion.

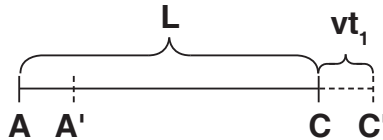

Fig. 12.3. Length contraction.

$t_1 = \text{time out}$

$t_2 = \text{time back}$

$$L + vt_1 = ct_1 \Rightarrow t_1 = \frac{L}{c-v} \quad \dots\dots\dots\text{Equation 12-6}$$

Similarly, $L - vt_2 = ct_2 \Rightarrow t_2 = \frac{L}{c+v} \quad \dots\dots\dots\text{Equation 12-7}$

$$t = t_1 + t_2 = \frac{2Lc}{c^2 - v^2}$$

But $t = \frac{t_0}{\sqrt{1-v^2/c^2}}$ (equation 12-3)

$$L = \frac{c}{2} \times \frac{t_0}{\sqrt{1-\frac{v^2}{c^2}}} \times \left(1 - \frac{v^2}{c^2}\right)$$

$$\therefore$$

Since t is the total time (out and back), using equation (12-1);

$$ct_0 = 2L_0$$

$$L = L_0 \sqrt{1-v^2/c^2} \quad \dots\dots\dots\text{Equation 12-8}$$

Substituting equation (12-5) gives

$$L = \frac{L_0}{\gamma}, \text{ here } \gamma = \frac{1}{\sqrt{1-v^2/c^2}} \geq 1 \quad \dots\dots\dots \text{Equation 12-9}$$

EXAMPLE 12.2

A metre stick zips by you with a speed of $0.9c$. The length of the stick is along its direction of motion. How long does it appear to be?

Solution:

$$L = L_p \sqrt{1 - v^2/c^2} = 1\text{m} \sqrt{1 - (0.9)^2} = 0.44 \text{ m}$$

Momentum, Mass and Energy

Einstein found that momentum;

$$p = \gamma p_0 \text{ and hence } m = \gamma m_0$$

$$\therefore m = \frac{m}{\sqrt{1 - \frac{v^2}{c^2}}}$$

$$p = \frac{m}{\sqrt{1 - v^2/c^2}} = \gamma mv \quad \dots\dots\dots \text{Equation 12-10}$$

EXAMPLE 12.3

A proton travels at a speed of $0.9c$. Compare its relativistic and classical momenta.

Solutions:

$$p_{cl} = mv = (1.67 \times 10^{-27} \text{ kg})(0.9 \times 3 \times 10^8 \text{ m/s}) \\ = 4.51 \times 10^{-19} \text{ kg.m/s}$$

$$P_{rel} = \frac{4.51 \times 10^{-19}}{\sqrt{1 - (0.9)^2}} = 1.03 \times 10^{-8} \text{ kgm/s}$$

As $v \rightarrow c$, $m \rightarrow \infty$. Thus, infinite energy would be needed to accelerate an object to the speed of light. Einstein showed the total energy of a free body;

$$E = mc^2 = m_0c^2 + k.e$$

where m_0c^2 is the mass energy of the body.

As space and time are united in the theory, so are momentum and energy. We see here m_0 is rest mass, p is momentum and c is speed of light.

$$E^2 = p^2c^2 + m_0^2c^4 \quad \dots\dots\dots \text{Equation 12-11}$$

if no potential energy terms exist.

But also $E = hf$

$$\therefore h^2 f^2 = p^2 c^2 + m_0^2 c^4$$

If the rest mass is zero,

$$p = \frac{E}{c} = \frac{hf}{e} = \frac{h}{\lambda} \quad \text{.....Equation 12-12}$$

EXAMPLE 12.4

An electron has a speed of $0.8c$. What is its kinetic energy?

Solution:

$$\begin{aligned} \text{KE} &= \frac{mc^2}{\sqrt{1-v^2/c^2}} - mc^2 = \frac{9.11 \times 10^{-31} \times 3 \times 10^8}{\sqrt{1-(0.8)^2}} - 9.11 \times 10^{-31} \times 3 \times 10^8 \\ &= 1.37 \times 10^{-13} \text{ J} - 8.2 \times 10^{-14} \text{ J} = 5.5 \times 10^{-14} \text{ J} \end{aligned}$$

or comparison, the classical expression for KE would give

$$KE = \frac{1}{2}mv^2 = \frac{1}{2} (9.11 \times 10^{-31} \text{ kg})(0.8 \times 3 \times 10^8 \text{ m/s})^2 = 2.62 \times 10^{-14} \text{ J}$$

Application Activity 12.1

1. An electron has a speed of $0.1c$. What is its kinetic energy?
2. Calculate the rest mass energy of the electron in electron volts.
3. Find the kinetic energy released in the fusion reaction given below:

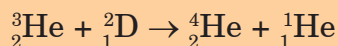

The rest mass energies of the nuclei are:

$${}^3_2\text{He} : 2,809.4 \text{ MeV}$$

$${}^2_1\text{D} : 1,876.1 \text{ MeV}$$

$${}^4_2\text{He} : 3,728.4 \text{ MeV}$$

$${}^1_1\text{H} : 938.8 \text{ MeV}$$

12.3 CONCEPT OF FRAME OF REFERENCE

Imagine you threw and caught a ball while you were on a train moving at a constant velocity past a station. To you, the ball appears to simply travel vertically up and then down under the influence of gravity. However, to an observer stood on the station platform, the ball would appear to travel in a parabola, with a constant horizontal component of velocity equal to the velocity of the train. This is illustrated in Fig.12-4 below.

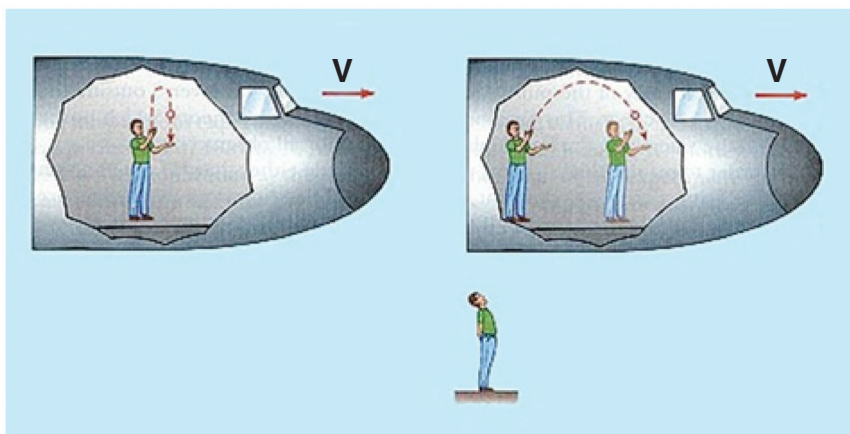

Fig. 12.4. The concept of the frames of reference.

The different observations occur because the two observers are in different *frames of reference*.

A frame of reference is a set of coordinates that can be used to determine positions and velocities of objects in that frame; different frames of reference move with respect to one another.

This means that when you are standing on the ground, that is your frame of reference. Anything that you see, watch or measure will be compared to the reference point of the ground. If a person is standing in the back of a moving truck, the truck is now the frame of reference and everything will be measured compared to it.

Types of Frame of Reference

There are two types of frames of reference.

Inertial Frame of Reference: It is a frame of reference in which a body remains at rest or moves with constant linear velocity unless acted upon by forces. Any frame of reference that moves with constant velocity with respect to an inertial system is itself an inertial system. In other words, it is the frame of reference in which Newton's first law of motion holds good.

Non-inertial Frame of Reference: This is a frame of reference that is undergoing acceleration with respect to an inertial frame. An accelerometer at rest in a non-inertial frame will in general detect a non-zero acceleration. In this frame of reference, Newton's first law of motion does not hold good.

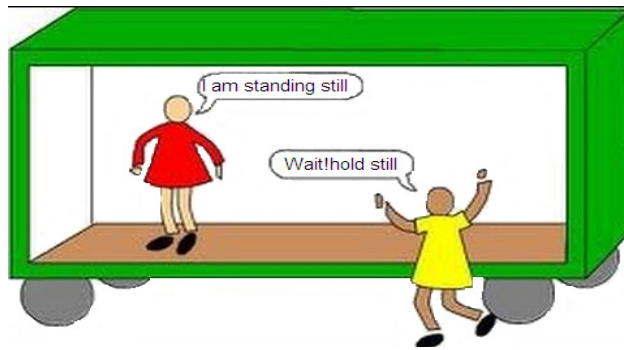

Fig. 12.5. Frames of reference.

12.4 GALILEAN EQUATION OF TRANSFORMATION

Galilean transformations, also called Newtonian transformations, are set of equations in classical physics that relate the space and time coordinates of two systems moving at a constant velocity with respect to each other. Galilean transformations formally express the ideas that space and time are absolute; that length, time, and mass are independent of the relative motion of the observer; and that the speed of light depends upon the relative motion of the observer.

Let there be two inertial frames of references S and S' where S is the stationary frame of reference and S' is the moving frame of reference. At time $t = t' = 0$, i.e., in the start, they are at the same position, i.e., observers O and O' coincide. After that S' frame starts moving with a uniform velocity v along x axis.

Let an event happen at position A in the frame S' . The coordinate of the P will be x' according to O' , the observer in S' and it will be x according to O in S . The frame S' has moved a distance vt in time t .

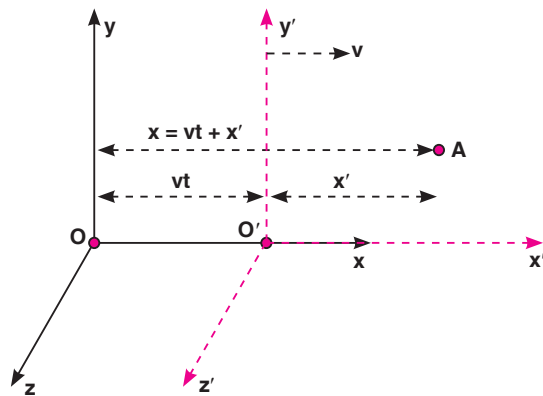

Fig. 12.6. Galilean Transformations.

The Galilean transformation relates the coordinates of events as measured in both frames. Given the absolute nature of time, Newtonian physics, it is the same for both frames. So, this may look over-elaborate if we write

$$t = t'$$

It is seen that in direction y and z , displacements remain the same. So, we may summarise these displacements as:

$$x = x' + vt$$

$$y = y'$$

$$z = z'$$

This set of equations is known as the Galilean Transformation. They enable us to relate a measurement in one inertial reference frame to another.

EXAMPLE 12.5

If a vehicle is moving in x -direction in system S , then what would be the velocity of the vehicle in S' ? and

$$v' = \frac{dx'}{dt}$$

$$x' = x - vt$$

$$v' = \frac{d(x - vt)}{dt}$$

\therefore

\Rightarrow

$$v' = \frac{dx}{dt} - v \frac{dt}{dt}$$

$$v' = v_x - v$$

Activity 12-1: Frames of Reference

Aim: this activity aims at explaining the frames of reference.

a) How many passengers are moving? How many passengers are not moving? Explain your answer

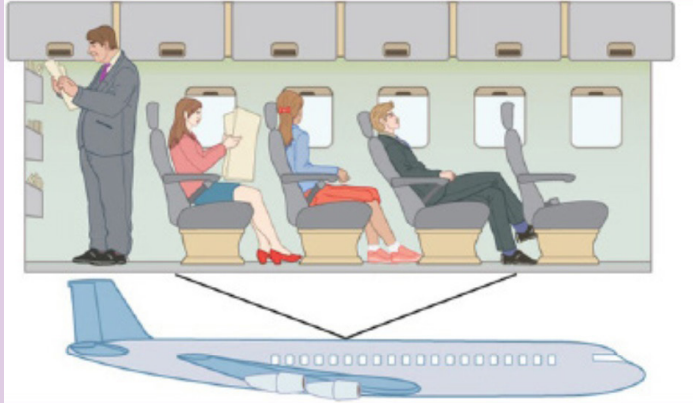

b) How many images there on the frame? Explain your answer. (do not consider the ground and the sky)



12.5 POSTULATES OF SPECIAL THEORY OF RELATIVITY

With two deceptively simple postulates and a careful consideration of how measurements are made, Einstein produced the theory of special relativity.

First postulate: The Principle of Relativity

This states that the laws of physics are the same in all inertial frames of reference.

This postulate relates to reference frames. It says that there is no preferred frame and, therefore, no absolute motion.

To understand the meaning of this postulate, consider the following situation.

You are sitting in a train that is stopped at a railway station. Another train is facing the opposite direction on the track directly beside you. Ten minutes before your train is due to leave, you look out through the window at the other train and see that it is slowly starting to move relative to yours. Your first reaction would probably be one of surprise: your train was leaving early! After passing the train from your window, you might notice that the station was still there, and you realize that it was the other train that was moving.

Second postulate: The Principle of Invariant Light Speed

The speed of light is a constant, independent of the relative motion of the source and observer.

The speed of light in vacuum ($c = 3 \times 10^8$ m/s) is so high that we do not notice a delay between the transmission and reception of electromagnetic waves under normal circumstances. The speed of light in vacuum is actually the only speed that is absolute and the same for all observers as was stated in the second postulate.

12.6 CONCEPT OF SIMULTANEITY

The concept of simultaneity says that two events that are simultaneous to one observer are not necessarily simultaneous to a second observer. Both observers are correct in their observations -- there is no best or preferred frame of reference.

If the speed of light is the same in all moving coordinate systems, this means that events that occur simultaneously in one system may not be observed as being simultaneous in another coordinate system.

An example is illustrated in the Fig. 12.7 below.

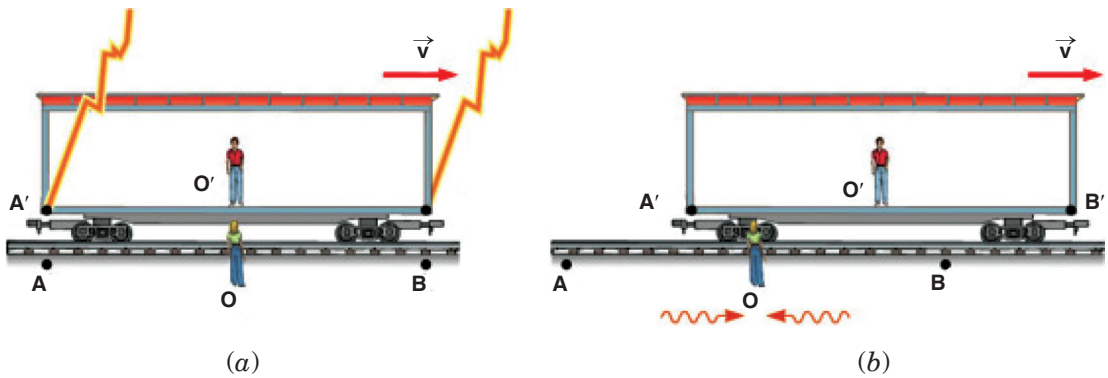

Fig. 12.7. The concept of simultaneity.

An observer O' stands in the middle of a moving boxcar and another observer O stands at rest beside the track. When the positions of the observers coincide, a lightning bolt strikes at each end of the boxcar, leaving marks on the ground and at each end of the boxcar. The light from the lightning strikes at A and B reaches to observer O at the same time, so observer O' concludes that the lightning strikes occurred simultaneously. But to observer O' in the moving boxcar, the lightning strikes do not appear to occur at the same time. The light traveling from A' to O' travels further than the light from B' to O' . Because of the motion, O' moves towards the incoming beam from B' and away from the incoming beam from A' . So to observer O' the strike at B' appeared to occur before the strike at A' .

END OF UNIT ASSESSMENT

1. If you were on a spaceship travelling at $0.50c$ away from a star, when would the starlight pass you?
2. Does time dilation mean that time actually passes more slowly in moving reference frames or that it only seems to pass more slowly?
3. If you were travelling away from the Earth at $0.50c$, would you notice a change in your heartbeat? Would your mass, height, or waistline change? What would observers on the earth using a telescope see you say about you?
4. What happens to the relativistic factor $\sqrt{1 - v^2/c^2}$ when objects travel at normal everyday velocities?
5. A spaceship travels at $0.99c$ for 3 years ship time. How much time would pass on the earth?
6. A spaceship is travelling at a speed of $0.94c$. It has gone from the earth for a total of 10 years as measured by the people of the earth. How much time will pass on the spaceship during its travel?

7. A spaceship has gone from the earth for a total time of 5 years ship time. The people on the earth have measured the time for the ship to be away to 25 years. How fast was the ship travelling?
8. A 520 m long (measured when the spaceship is stationary) spaceship passes by the earth. What length would the people on the earth say the spaceship was as it passed the earth at $0.87c$?
9. A 25 m long beam is shot past a stationary space station at $0.99c$. What length does the people on board the space station measure the beam to be?
10. A 100 m long steel beam is moving past the earth. Observers on the earth actually measure the steel beam to be only 50 m long. How fast was the beam travelling?

UNIT SUMMARY

Definition of relativity

Anything except light moves with respect to time and space depends on the position and movement of someone who is watching.

Concept of space, time and mass

- Time Dilation

Time dilation is the phenomenon where two objects moving relative to each other (or even just a different intensity of gravitational field from each other) experience different rates of time flow. The total time is given by

$$t = \gamma t_0$$

where
$$\gamma = \frac{1}{\sqrt{1 - v^2/c^2}}$$

- Length Contraction

If we turn our light beam clock to face in the direction of motion, time dilation implies length contraction.

$$L = L_0 \sqrt{1 - v^2/c^2}$$

Postulates of special theory of relativity

- First postulate

This states that the laws of physics are the same in all inertial frames of reference.

This postulate relates to reference frames. It says that there is no preferred frame and, therefore, no absolute motion.

- Second postulate

This states that speed of light, c is a constant, independent of the relative motion of the source and observer.

BIBLIOGRAPHY

1. Abott, A. (1989). *Physics*. Chicago: Heinman Educational Publisher.
2. David, V. F., Griffith, T., John, G. L., Jay, M., Beth, M., Steve, M., & Camille, W. (2006).
Science Explorer. Mexico: Pearson Prentice hall.
3. Elizabeth, C., Donald, C., Linda, C., Lisowski, M., & Jan, J. (2006).
Science Explorer. Mexico: Pearson Prentice Hall.
4. Nelkon, M., & Parker, H. (1995). *Advanced Level Physics*. London: Heinemann.
5. Richard, O. (2009). *Physics for Rwanda Secondary School*. Kigali: Fountain.
6. Tom, D. (2000). *Advanced Physics*. London: Hodder Education.
7. Wysession, M., Frank, D., & Yancopoulos, S. (2004). *Physical Science*. Boston, Massachusetts, Upper Saddle River, New Jersey: Pearson Prentice Hall.
8. Valerio Faraoni,(2003): *Exercises on Environmental Physical*, Springer, ISBN-10: 0-387-33912-4 ISBN-13: 978-0387-33912-2
9. Peter Hughes, N.J. Mason,(2001): *Introduction to Environmental Physics: Planet Earth, Life and Climate*,
10. Gerard P.A. Bot, (2010): *Agricultural Physics*. Publisher: Springer, ISBN: 978-3-540-74697-3, ISBN: 978-3-540-74698-0
11. Franklin Hiram King, (1904): *A Text Book of the Physics of Agriculture*, Publisher: Madison, Wis., ISBN: 1176279092 / ISBN-13: 9781176279094
12. Roger A. Freedman and William J. Kaufmann III, (2008): *Stars and galaxies. Universe, Third Edition*, W.H. Freeman and Company, New York. ISBN-13:978-0-7167-9561-2
13. Neil F. Comins, (2009): *Discovering the Universe: From the stars to the Planets*, W.H. Freeman and Company, New York. ISBN-13:978-1-4292-3042-1
14. STACY E. PALEN, (2002): *Theory and Problems of Astronomy*. Schaumâ™s Outline Series, McGraw-HILL.

15. STAN GIBILISCO, (2003): Astronomy demystified. McGraw-HILL
16. Marc L. KUTNER,(2003): Astronomy: A Physical Perspective, Cambridge University Press, ISBN-13:978-0-511-07857-6
17. Stan Gibilisco (2010): Electronics Demystified, Second Edition. ISBN-13: 978-0071768078 ISBN-10: 0071768076
18. Advanced Physics, Tom Duncan, John Murray (2000).
19. Fundamentals of Physics, David Halliday, Robert Resnick and Jearl Walker, 7th Edition John Wily (2004).
20. Hastings, R. J., 1987, "Creation Physics" and the speed of light; Unpublished manuscript.
21. Morse, P., 1974, Thermal Physics: New York, Benjamin.
22. Tryon, E. P., 1989, Cosmic Inflation, in Meyers, R. A., ed., Encyclopedia of Astronomy and Physics: San Diego, California, Academic Press.
23. Weinberg, S., 1977, the First Three Minutes: A Modern View of the Origin of the Universe: New York, Basic Books.