

**PHYSICS**  
**FOR**  
**ASSOCIATE NURSING PROGRAM**

**STUDENT'S BOOK**

**Senior 6**

© 2022 Rwanda Basic Education Board

All rights reserved

This book is property of the Government of Rwanda. Credit must be given to  
REB when the content is quoted

## FOREWORD

Dear Student,

Rwanda Basic Education Board is honored to present to you this Physics Book for Senior six which serves as a guide to competence-based teaching and learning to ensure consistency and coherence in the learning of physics. The Rwandan educational philosophy is to ensure that you achieve full potential at every level of education which will prepare you to be well integrated in society and exploit employment opportunities.

The government of Rwanda emphasizes the importance of aligning teaching and learning materials with the syllabus to facilitate your learning process. Many factors influence what you learn, how well you learn and the competences you acquire. Those factors include the instructional materials available among others. Special attention was paid to the activities that facilitate the learning process in which you can develop your ideas and make new discoveries during concrete activities carried out individually or with peers.

In competence-based curriculum, learning is considered as a process of active building and developing knowledge and meanings by the learner where concepts are mainly introduced by an activity, a situation or a scenario that helps the learner to construct knowledge, develop skills and acquire positive attitudes and values.

For effective use of this textbook, your role is to:

- Work on given activities which lead to the development of skills
- Share relevant information with other learners through presentations, discussions, group work and other active learning techniques such as role play, case studies, investigation and research in the library, from the internet or from your community;
- Participate and take responsibility for your own learning;
- Draw conclusions based on the findings from the learning activities.

I wish to sincerely extend my appreciation to REB staff who organized the editing process of this book. Special gratitude goes to the lecturers, teachers, illustrators and designers who diligently worked to successful completion of this book. Any comment or contribution would be welcome for the improvement of this textbook for the next edition.

**Dr. Nelson MBARUSHIMANA**

**Director General, REB**



## **ACKNOWLEDGEMENT**

I wish to express my appreciation to all the people who played a major role in editing process of Physics book for senior six. It would not have been successful without their active participation.

Special thanks are given to those who gave their time to read and refine this textbook to meet the needs of competence-based curriculum. I owe gratitude to different Universities and schools in Rwanda that allowed their staff to work with REB to edit this book. I therefore, wish to extend my sincere gratitude to lecturers, teachers, illustrators, designers and all other individuals whose efforts in one way or the other contributed to the success of this edition.

Finally, my word of gratitude goes to the Rwanda Education Board staff particularly those from Curriculum, Teaching and Learning Resources Department who were involved in the whole process of editorial work.



**Joan MURUNGI,**

**Head of Department of Curriculum, Teaching and Learning Resources**

# Table of Contents

<b>PHYSICS</b> .....	<b>I</b>
<b>STUDENT'S BOOK</b> .....	<b>I</b>
<b>SENIOR 6</b> .....	<b>I</b>
<b>FOREWORD</b> .....	<b>III</b>
<b>ACKNOWLEDGEMENT</b> .....	<b>IV</b>
<b>UNIT1: SOUND WAVES</b> .....	<b>1</b>
1.1. Characteristics and properties of sound waves .....	2
1.2 Production of stationary sound waves.....	9
1.3 Characteristics of musical notes .....	26
1.4 Applications of sound waves .....	30
<b>UNIT2: APPLICATION OF PHYSICS IN AGRICULTURE</b> .....	<b>41</b>
2.1 Atmosphere and its constituents.....	42
2.2 Heat and mass transfer .....	49
2.3 Physical properties of soil .....	55
2.4 Mechanical weathering.....	60
<b>UNIT3: FOSSIL AND NON-FOSSIL FUEL AND POWER PRODUCTION</b> .....	<b>72</b>
3.1.Fossil fuels and non-fossil fuels.....	75
3.2.Storage and transportation of different types of fossil fuels .....	77
3.3 Advantages and disadvantages of fossil fuels .....	85
3.4 Energy production using fossil fuels .....	86
3.5 Nuclear fuel and nuclear fission .....	87
3.6 Controlled fission (power production) .....	88
3.7 Uncontrolled fission (nuclear weapons) .....	88
3.8 Impacts of nuclear weapons .....	89
3.9 Energy transformations in a nuclear power station.....	90
3.10 Problems associated with the production of nuclear power .....	91
3.11 Environmental problems of fossil fuels .....	92
3.12 Safety issues and risks associated with nuclear power.....	96

<b>UNIT4: ATOMIC NUCLEI AND RADIOACTIVE DECAY .....</b>	<b>101</b>
4.1 Atomic nuclei-nuclide.....	103
4.2 Mass defect and binding energy .....	108
4.3 Radioactivity and nuclear stability .....	113
4.4 Application of radioactivity .....	125
4.5 Hazards and safety precautions of when handling radiations .....	130
<b>UNIT5: APPLICATIONS OF OPTICAL FIBER IN TELECOMMUNICATION SYSTEMS..</b>	<b>140</b>
5.1 Principles of operations of optical fibers .....	141
5.2 Types of optical fibers .....	149
5.3 Mechanism of attenuation.....	153
5.4 Optical transmitter and optical receiver .....	156
5.5. Uses of optical fibers.....	158
5.6 Advantages and disadvantages of optical fibers .....	159
<b>UNIT6: BLOCK DIAGRAM OF TELECOMMUNICATION .....</b>	<b>163</b>
6.1. Operating principle of microphone .....	164
6.2 Channels of signal transmission .....	166
6.3 Carrier wave and modulator .....	169
6.4 Oscillator, radio frequency amplifier and power amplifier .....	170
6.5 Antennas .....	174
6.6 Block diagrams of telecommunication.....	177
<b>UNIT7: NATURE OF PARTICLES AND THEIR INTERACTIONS .....</b>	<b>184</b>
7.1 Elementary particles.....	185
7.2 Classification of elementary particles. ....	187
7.3 Anti particle and pauli's exclusion principle .....	190
7.4 Fundamental interactions by particle exchange.....	192
7.5 Uncertainty principle and particle creation .....	195
7.6 Matter and antimatter (pair production and annihilation) .....	198
<b>UNIT8: PROPERTIES AND BASIC PRINCIPLES OF QUARKS .....</b>	<b>203</b>
8.1 Introduction.....	204
8.2 Types of quarks.....	206
8.3 Baryon number, lepton number and their laws of conservation.....	208

8.4 Spin structures of hadrons (hadrons and mesons) .....	211
8.5 Color in forming of bound states of quarks. ....	215
<b>UNIT9: EFFECT OF X-RAYS.....</b>	<b>225</b>
9.1 Production of x-rays and their properties .....	226
9.2 The origins and characteristic features of an x-ray spectrum .....	229
9.3 Applications and dangers of x-rays .....	233
9.4 Problems involving accelerating potential and minimum wavelength. .....	238
<b>UNIT10: EFFECT OF LASER .....</b>	<b>245</b>
10.1 Concept of laser .....	246
10.2 Properties of laser light .....	254
10.3 Applications and dangers of misuse of laser .....	256
<b>UNIT11: MEDICAL IMAGING .....</b>	<b>265</b>
11.1 X-ray imaging.....	266
11.2 Ultrasonic imaging .....	276
11.3 Scintigraphy (nuclear medicine) .....	283
11.4 Magnetic resonance imaging (mri).....	285
11.5 Endoscopy.....	290
<b>UNIT12: RADIATIONS AND MEDICINE .....</b>	<b>298</b>
12.1 Radiation dose .....	299
12.2 Biological effects of radiation exposure.....	308
12.3 Concept of balanced risk. ....	316
12.4 The half-lives: physical, biological, and effective.....	318
<b>BIBLIOGRAPHY .....</b>	<b>325</b>



# UNIT 1

## SOUND WAVES



**Key unit competence:** Analyze the effects of sound waves in elastic medium  
**My goals**

- Describe how sound propagates through a substance
- Give the characteristics of sound.
- Relate loudness and pitch to amplitude and frequency
- Carry out calculations relating decibels and intensity
- Establish relationship between characteristics of notes and sound waves
- Explain beats and establish beat frequency
- Explain Doppler – Fizeau effect.
- Give examples of musical pipe instruments.
- Explain Doppler – Fizeau effect.
- Give examples of musical pipe instruments.
- Establish the fundamental frequency and 2<sup>nd</sup> harmonic, 3<sup>rd</sup> harmonic, in vibrating strings and in pipes

## INTRODUCTORY ACTIVITY

1. Most people like to listen to music, but hardly anyone likes to listen to noise. What is the difference between a musical sound and noise?
2. A guitarist plays any note. The sound is made by the vibration of the guitar string and propagates as a wave through the air and reaches your ear. Which of the following statement is the right?
  - The vibration on the string and the vibration in the air have the same wavelength.
  - They have the same frequency.
  - They have the same speed.
  - None of the above is the same in the air as it is on the string.

### Questions

- a. Explain the meaning of underlined terms used in the text above
- b. Do you think, it was 100% correct for Claudette to relate sound waves to light waves. Explain.
- c. There is somewhere where she was asked to discuss the different media in which sound waves can travel. Discuss these different media and talk about velocity of sound waves in the stated media.
- d. In one of the paragraph, Claudette said that the laws governing reflection and refraction of sound waves were similar to those of light. Can you explain these laws (Use diagrams where possible)
- e. Assuming that you were an interviewer and the interview was out of 80. What mark would you award Claudette? Why?

## 1.1. CHARACTERISTICS AND PROPERTIES OF SOUND WAVES

### ACTIVITY 1.1: Properties of sound

**Read the scenario below and answer the questions that follow.**

On an interview for Physics placement in a certain school in Rwanda, Claudette a S.6 leaver who had applied for the job was asked about **sound waves** during the interview. She was asked to state the **properties** of sound waves. Confidently, she responded that the properties are **reflection, refraction, diffraction** and **interference**. This was enough to make Claudette pass the first level of the interview.

However, in the second step, she was required to discuss different media in which sound waves can **propagate**. Claudette started discussing these different media. What surprised the interviewer was Claudette's ability to relate sound waves to other kinds of waves stating that these waves behaves the same way when they pass from one medium to another.

Looking at Claudette's face, the interviewer asked her to discuss the **laws governing reflection and refraction of sound waves**. With a smile, she started by saying that since sound waves have the same properties as for light; these laws therefore do not change.

As she was attempting to state them, the interviewer stopped her and congratulated her upon her confidence and bravery she showed in the room. She was directly told that she was successful and she was given the job. Claudette is now working as assistant S2 Physics teacher and doubles as a Physics laboratory attendant.

### ***1.1.1 Properties of sound waves***

Most of us start our lives by producing sound waves! We spend much of our life surrounded by objects which produce sound waves. Most machines in use vibrate and produce sound so the only sure way to silence them would be to put them in vacuum where there would be no surrounding medium for the vibrating surfaces of the machine to push against, hence no sound waves. Some physiologists are concerned with how speech is produced, how speech impairment might be corrected, how hearing loss can be alleviated.

**Sound** is associated with our sense of hearing and, therefore, with the physiology of our ears that intercept the sound and the psychology of our brain which interprets the sensations that reach our ears. Sound waves are longitudinal mechanical waves that can travel through solids, liquids, or gases.

As the sound wave propagates, many interactions can occur, including reflection, refraction, diffraction and interference. When a sound wave hits a surface, a part of the energy gets scattered while a part of it is absorbed. **Absorption** is the phenomenon of the wave where the energy of sound wave gets transformed from one form to another. The high frequency sound waves are more easily absorbed than low frequency sounds. It happens most with the soft materials.

## 1.1.2 Characteristics of sound waves

### ACTIVITY 1.2: Characteristics of sound waves

1. How to calculate the speed of sound waves in different materials.
2. How to calculate the intensity of a sound wave.
3. From the Fig.1.2, can you hear the ultrasound waves that a bat uses for echolocation? Why or why not?

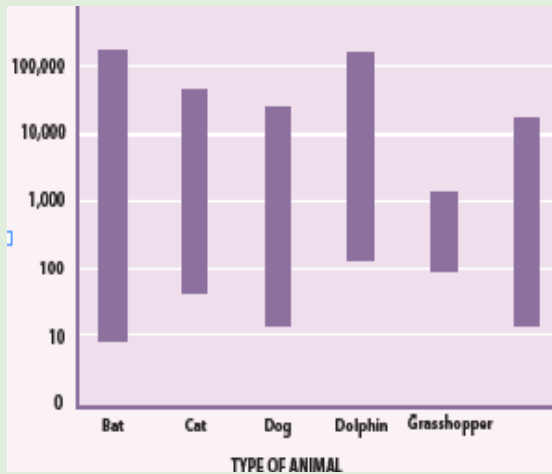

Fig.1. 2: Range of frequencies heard by various animals and human (Randall & Knight,-  
Physics for scientists and engineers: Strategic approach., 2008)

Usually, the characteristics used to describe waves are period, frequency, wavelength, and amplitude.

#### a. Frequency ranges

Any periodic motion has a frequency, which is the number of complete cycles in a second and a period which is the time used to complete one cycle. While the frequency is measured in Hertz (**Hz**), the period is measured in seconds (**s**).

For a wave, the frequency is the number of wave cycles that pass a point in a second. A wave's frequency equals the frequency of the vibrating source producing the wave.

Sound waves are classified into three categories that cover different frequency ranges:

- **Audible soundlies** within the range of sensitivity of the human ear. They can be generated in a variety of ways, such as musical instruments, human voices, or loudspeakers. It is almost impossible to hear sounds outside the range of **20 Hz to 20 kHz**. These are the limits of audibility for human beings but the range decreases with age.

- **Infrasonic waves** have frequencies below the audible range. They are sound waves with frequencies that are below 20 Hz limit. Some animals such as elephants can use infrasonic waves to communicate with each other, even when they are separated by many kilometers. Rhinoceros also use infrasonic as low as 5 Hz to call one another.
- **Ultrasonic waves** have frequencies above the audible range. They are sound waves whose frequencies are higher than 20 KHz. You may have used a “silent” whistle to retrieve your dog. The ultrasonic sound emitted by that device is easily heard by dogs, although humans cannot detect it at all. Ultrasonic waves are also used in medical imaging.

Many animals hear a much wider range of frequencies than human beings do. For example, dog whistles vibrate at a higher frequency than the human ear can detect, while evidence suggests that dolphins and whales communicate at frequencies beyond human hearing (ultrasound) (Cutnell & Johnson, 2006).

### b. Wavelength

**Wavelength** is the distance covered by a wave in a period. It is represented by the separation between a point on one wave and a similar point on the next cycle of the wave. For a transverse wave, wavelength is measured between adjacent crests or between adjacent troughs. For a longitudinal wave such as sound wave, wavelength is the distance between adjacent compressions or rarefaction.

### c. Speed of sound

For a periodic wave, the shape of the string at any instant is a repeating pattern. The length of one complete wave pattern is the distance from one crest to the next or from one trough to the next or from any point to the corresponding point on the next repetition of the wave shape. We call this distance the **wavelength** of the wave, denoted by the Greek letter lambda ( $\lambda$ ).

The wave pattern travels with constant speed and advances a distance of one wavelength in a time interval of one period T. So the wave speed is given by

$$v = \frac{\lambda}{T} = \lambda f \quad (1.01)$$

where f is the frequency of the wave.

Sound travels faster in liquids and solids than in gases, since the particles in liquids and solids are closer together and can respond more quickly to the motion of their neighbors. As examples, the speed of sound is 331 m/s in air, 1500 m/s in water and 5000 m/s in iron (though these can change depending on temperature and pressure). Sound does not travel in vacuum.

## Example 1.1: Wavelength of musical sound

### Example 1.1 Wavelength of a musical sound

- 1) Sound waves can propagate in air. The speed of the sound depends on temperature of the air; at 200 C it is 344 m/s it is. What is the wavelength of a sound wave in air if the frequency is 262 Hz (the approximate frequency of middle C on a piano)?

**Answer:**

Using Equation of wave (1.01):  $\lambda = \frac{v}{f} = \frac{344 \text{ m/s}}{262 \text{ Hz}} = 1.31 \text{ m}$

Factors which affect the velocity of sound in air

- The speed of sound waves in a medium depends on the compressibility and density of the medium. If the medium is a liquid or a gas and has a bulk modulus  $B$  and density  $\rho$ , the speed of sound waves in that medium

is given by:  $v = \sqrt{\frac{B}{\rho}}$  (1.02)

- It is interesting to compare this expression with the equation

$v = \sqrt{\frac{T}{\mu}}$  applicable to transverse waves on a string. In both cases, the wave speed depends on an elastic property of the medium (bulk modulus  $B$  or tension in the string  $T$ ) and on an inertial property of the medium (the density  $\rho$  or linear mass  $\mu$ ).

In fact, the speed of all **mechanical waves** follows an expression of the

general form  $v = \sqrt{\frac{\text{elastic property}}{\text{inertia property}}}$  (1.03)

- For longitudinal sound waves in a solid rod of material, for example, the speed of sound depends on Young's modulus  $Y$  and the density  $\rho$ . Changes of pressure have no effect on the velocity of sound in air.

**Sir Isaac Newton** showed that:  $v = \sqrt{\frac{P}{\rho}}$  (1.04)

- In accordance with Boyle's law, if the pressure of a fixed mass of air is doubled, the volume will be halved. Hence the density will be doubled. Thus at constant temperature, the ratio  $\frac{P}{\rho}$  will always remain constant no matter how the pressure may change. The speed of sound increases with temperature. If the air temperature increases at constant pressure the air will expand according to Charles' law, and therefore become less dense. The ratio  $\frac{P}{\rho}$  will therefore increase, and hence the speed of sound increases with temperature. For sound traveling through air, the relationship between wave speed and medium temperature is

$$v = v_0 \sqrt{\frac{T}{T_0}} \quad (1.05)$$

Where  $v_0 = 331 \text{ m/s}$  is the speed of sound in air(at 0 degree Celsius and normal pressure) .

- **The speed of sound in air** at standard temperature and pressure (25 °C, 760 mm of mercury) is 343 m/s. It is determined by how often the air molecules collide. The speed of sound increases by about 6 m/s if the temperature increases by 10 °C (Glencoe, 2005).

Medium	Speed(m s <sup>-1</sup> )
<b>Gases</b>	
Air(0°C)	331
Air(20°C)	343
Helium	965
Hydrogen	1284
<b>Liquids</b>	
Water(0°C)	1402
Water(20°C)	1482
Seawater	1522
<b>Solids</b>	
Aluminium	6420
Copper	3560
Steel	5941
Granite	6000
Vulcanised Rubber	54

## Example 1.2

Find the speed of sound in water, which has a bulk modulus of

$B = 2.1 \times 10^9 \text{ N/m}^2$  at a temperature of  $0^\circ\text{C}$  and a density of  $\rho = 1.00 \times 10^3 \text{ kg/m}^3$

### Answer

Using equation (1.02), we find that  $v = \sqrt{\frac{B}{\rho}} = \sqrt{\frac{2.1 \times 10^9 \text{ N/m}^2}{1.00 \times 10^3 \text{ kg/m}^3}} = 1.4 \text{ m/s}$

In general, sound waves travel more slowly in liquids than in solids because liquids are more compressible than solids.

## d. Amplitude

The amplitude of a wave is the maximum displacement of the medium from its rest position. The amplitude of a transverse wave is the distance from the rest position to a crest or a trough. The more energy a wave has, the greater is its amplitude.

### 1.1.3 Checking my progress

- The correct statement about sound waves is that:
  - They are transverse waves
  - They can be polarized
  - They require material medium to propagate
- Sound travels in
  - Air
  - Water
  - Iron
  - All of these
- Two men talk on the moon. Assuming that the thin layer of gases on the moon is negligible, which of the following is the right answer:
  - They hear each other with lower frequency
  - They hear each other with higher frequency
  - They can hear each other at such frequency
  - They cannot hear each other at all
- Do you expect an echo to return to you more quickly on a hot day or a cold day?
  - Hot day.
  - Cold day.
  - Same on both days.
- A sound wave is different than a light wave in that a sound wave is:
  - Produced by an oscillating object and a light wave is not.
  - Not capable of traveling through a vacuum.

- c. Not capable of diffracting and a light wave is.
  - d. Capable of existing with a variety of frequencies and a light wave has a single frequency.
6. A spider of mass 0.30 g waits in its web of negligible mass see Fig. below. A slight movement causes the web to vibrate with a frequency of about 15 Hz.



Fig.1. 3 A spider of mass waits in its web

- a. Estimate the value of the spring stiffness constant  $k$  for the web assuming simple harmonic motion.
- b. At what frequency would you expect the web to vibrate if an insect of mass 0.10 g were trapped in addition to the spider?

## 1.2 PRODUCTION OF STATIONARY SOUND WAVES

### ACTIVITY 1.3: Production of stationary sound waves



Fig.1. 4: A guitarist.

Look at the Fig.1.4 of guitarist and then answer the following question.

1. How do vibrations cause sound?
2. What determines the particular frequencies of sound produced by an organ or a flute?
3. How resonance occurs in musical instruments?
4. How to describe what happens when two sound waves of slightly different frequencies are combined?

### 1.2.1 Sound in pipes

The source of any sound is vibrating object. Almost any object can vibrate and hence be a source of sound. For musical instruments, the source is set into vibration by striking, plucking, bowing, or blowing. Standing waves (also known as stationary waves are superposition of two waves moving in opposite directions, each having the same amplitude and frequency) are produced and the source vibrates at its natural resonant frequencies.

The most widely used instruments that produce sound waves make use of vibrating strings, such as the violin, guitar, and piano or make use of vibrating columns of air, such as the flute, trumpet, and pipe organ. They are called **wind instruments**. We can create a standing wave:

- In a tube, which is open on both ends. The open end of a tube is approximately a node in the pressure (or an antinode in the longitudinal displacement).
- In a tube, which is open on one end and closed on the other end. The closed end of a tube is an antinode in the pressure (or a node in the longitudinal displacement).

In both cases a pressure node is always a displacement antinode and vice versa.

#### a. Tube of length $L$ with two open ends

An open pipe is one which is open at both ends. The length of the pipe is the distance between consecutive antinodes. But the distance between consecutive

antinode is  $\frac{\lambda}{2}$  i.e.  $= \frac{\lambda}{2}$  (1.06)

The longest standing wave in a tube of length  $L$  with two open ends has displacement antinodes (pressure nodes) at both ends. It is called the **fundamental**.

$$L = \frac{\lambda}{2} \Leftrightarrow \lambda = 2L \Rightarrow f_0 = \frac{v}{2L}$$

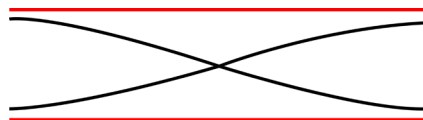

Fig.1. 5: Fundamental note (1<sup>st</sup> harmonic).

Notes with higher frequencies than fundamental can be obtained from the pipe by blowing harder. The stationary wave in the open pipe has always an antinode at each end.

$$L = \frac{3\lambda}{2} \Leftrightarrow \lambda = \frac{2L}{3} \Rightarrow f_2 = \frac{3v}{2L} = 3f_0$$

The next longest standing wave in a tube of length  $L$  with two open ends is the **second harmonic (first overtone)**. It also has displacement antinodes at each end.

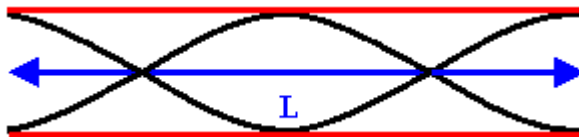

Fig.1. 6: First overtone (second harmonic).

The second overtone is obtained from Fig. 1.6 and is the third harmonic.

$$L = \frac{3\lambda}{2} \Leftrightarrow \frac{2L}{3} \Rightarrow f_2 = \frac{3v}{2L} = 3f_0$$

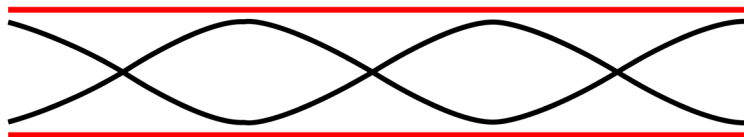

Fig.1. 7: Second overtone (third harmonic).

An integer number of half wavelength has to fit into the tube of length  $L$ :

$$L = \frac{n\lambda}{2} \Leftrightarrow \lambda = \frac{2L}{n} \Rightarrow f_{n-1} = \frac{nv}{2L} = nf_0 \quad (1.07)$$

For a tube with two open ends, all frequencies  $f_{n-1} = nf_0$  with  $n$  equal to an integer are **natural frequencies**.

The frequency  $f$  of fundamental note emitted by a vibrating string of length  $L$ , mass per unit length  $m$  and under tension  $T$  is given by

$$f = \frac{1}{2L} \sqrt{\frac{T}{\mu}} \quad (1.08)$$

### Example 1.3

The fundamental frequency of a pipe that is open at both ends is 594 Hz.

- How long is this pipe?
- Find the wavelength. Assume the temperature is 20°C
- Determine the fundamental frequency of the flute when all holes are covered and the temperature is 10 °C instead of 20 °C?

**Answer :**

a. Length of the pipe:  $L = \frac{v}{2f_0} = \frac{343 \text{ m/s}}{2 \times 594 \text{ Hz}} = 0.29 \text{ m}$

b. The wavelength:  $\lambda = 2L = 0.58 \text{ m}$

**Quick check 1.1:** Standing sound waves are produced in a pipe that is 1.20 m long. For the fundamental and first two overtones, determine the locations along the pipe (measured from the left end) of the displacement nodes and the pressure nodes if the pipe is open at both ends.

**b. Tube of length  $L$  with one open end and one closed end.**

The longest standing wave in a tube of length  $L$  with one open end and one closed end has a displacement antinode at the open end and a displacement node at the closed end.

This is the **fundamental**.  $L = \frac{\lambda}{4} \Leftrightarrow \lambda = 4L \Rightarrow f_0 = \frac{v}{4L}$  (1.09)



Fig.1. 8: Fundamental note (1<sup>st</sup> harmonic).

The next longest standing wave in a tube of length  $L$  with one open end and one closed end is the **third harmonic (second overtone)**. It also has a displacement antinode at one end and a node at the other.

$$L = \frac{3\lambda}{4} \Leftrightarrow \lambda = \frac{4L}{3} \Rightarrow f_1 = \frac{3v}{4L} = 3f_0 \quad (1.10)$$

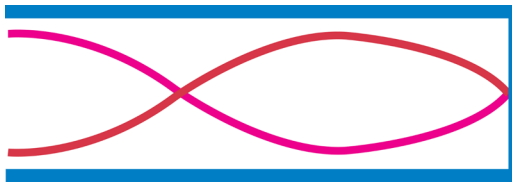

Fig.1. 9: First overtone (third harmonic)

The next longest standing wave in a tube of length  $L$  with one open end and one closed end is the **second overtone (fifth harmonic)**.

$$L = \frac{5\lambda}{4} \Leftrightarrow \lambda = \frac{4L}{5} \Rightarrow f_2 = \frac{5v}{4L} = 5f_0 \quad (1.11)$$

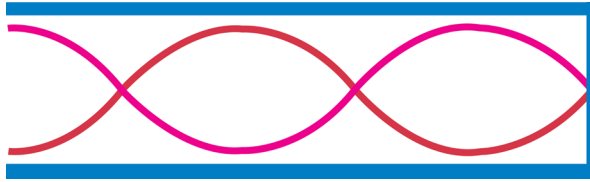

Fig.1. 10: Second overtone (fifth harmonic)

An odd-integer number of quarter wavelength has to fit into the tube of length  $L$ .

$$L = \frac{(2n+1)\lambda}{4} \Leftrightarrow \lambda = \frac{4L}{2n+1} \Rightarrow f_n = \frac{(2n+1)v}{4L} = (2n+1)f_0 \quad (1.12)$$

For a tube with one open end and one closed end, frequencies

$$f_n = \frac{(2n+1)v}{4L} = (2n+1)f_0, \text{ with } n \text{ equal to an odd integer are } \mathbf{\text{natural frequencies.}}$$

Only odd harmonics of the fundamental are natural frequencies.

Another way to analyze the vibrations in a uniform tube is to consider a description in terms of the pressure in the air. Where the air in a wave is compressed, the pressure is higher, whereas in a wave expansion (or rarefaction), the pressure is less than normal. We call a region of increased density a compression; a region of reduced density is a rarefaction.

The wavelength is the distance from one compression to the next or from one rarefaction to the next.

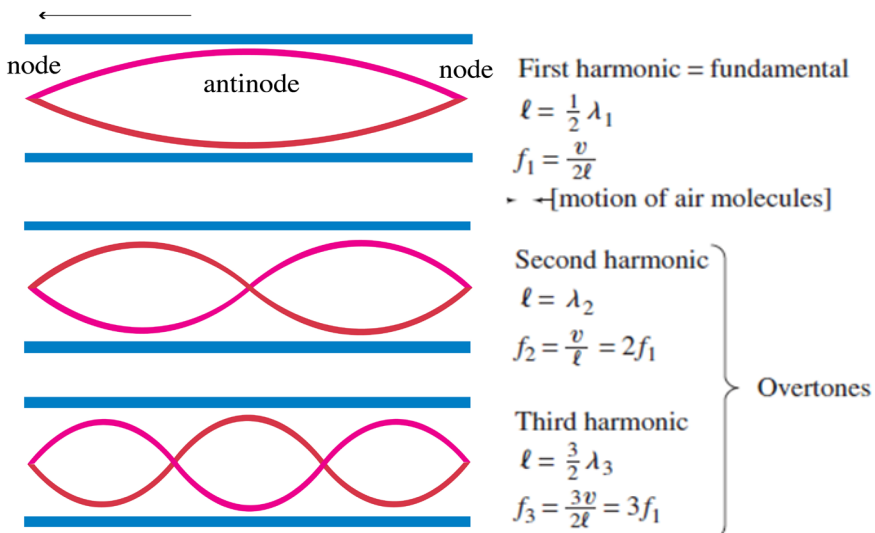

Fig.1. 11: Pressure variation in the air: Graphs of the three simplest modes of vibration (standing waves) for a uniform tube open at both ends ("open tube").

The open end of a tube is open to the atmosphere. Hence the pressure variation at an open end must be a node: the pressure does not alternate, but remains at the outside atmospheric pressure as shown in Fig.1.12.

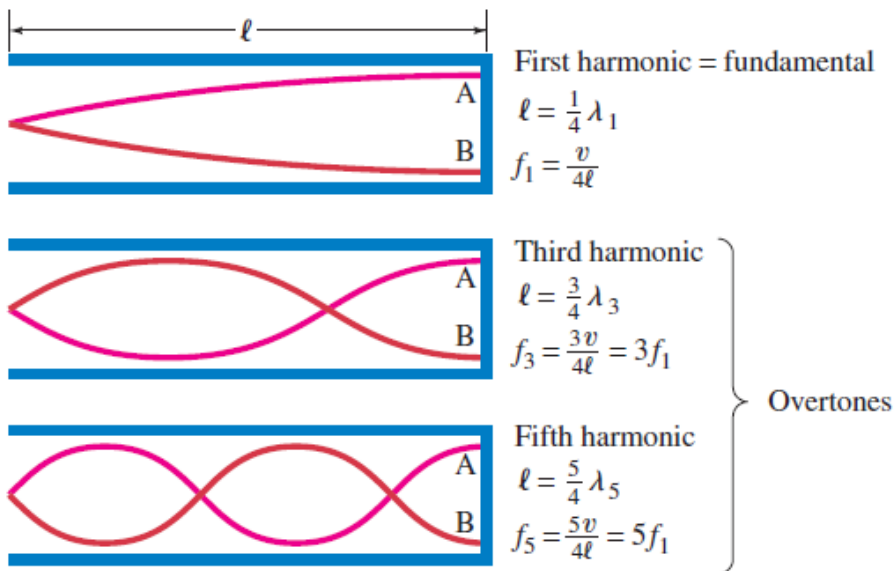

Fig.1. 12: Modes of vibration (standing waves) for a tube closed at one end (“closed tube”).

If a tube has a closed end, the pressure at that closed end can readily alternate to be above or below atmospheric pressure. Hence there is a pressure *antinode* at a closed end of a tube. There can be pressure nodes and antinodes within the tube as shown in Fig.1.12.

### Example 1.4

1. A section of drainage culvert 1.23 m in length makes a howling noise when the wind blows.

- Determine the frequencies of the first three harmonics of the culvert if it is open at both ends. Take  $v = 343$  m/s as the speed of sound in air.
- What are the three lowest natural frequencies of the culvert if it is blocked at one end?
- For the culvert open at both ends, how many of the harmonics present fall within the normal human hearing range (20 Hz to 17 000 Hz)?

Answer

- The frequency of the first harmonic of a pipe open at both ends is Because both ends are open, all harmonics are present; thus,

$$f_2 = 2f_1 = 2 \times 139 \text{ Hz} = 278 \text{ Hz} \text{ and } f_3 = 3f_1 = 3 \times 139 \text{ Hz} = 417 \text{ Hz}$$

$$f_1 = \frac{v}{2L} = \frac{343 \text{ m/s}}{2 \times 1.23 \text{ m}} = 139 \text{ Hz}$$

b. The fundamental frequency of a pipe closed at one end is

$$f_1 = \frac{v}{4L} = \frac{343 \text{ /s}}{4 \times 1.23 \text{ m}} = 69.7 \text{ Hz}$$

In this case, only odd harmonics are present; hence, the next two harmonics have frequencies

$$f_3 = 3f_1 = 3 \times 69.7 \text{ Hz} = 209 \text{ Hz} \text{ and } 5f_1 = 5 \times 69.7 \text{ Hz} = 349 \text{ Hz}$$

c. Because all harmonics are present, we can express the frequency of the highest harmonic heard as  $f_n = nf_1$  where  $n$  is the number of harmonics that we can hear.

For  $f_n = 17000 \text{ Hz}$ , we find that the number of harmonics present in the audible range is

$$n = \frac{17000}{139} = 122$$

Only the first few harmonics are of sufficient amplitude to be heard.

### Quick check 1.2:

Standing sound waves are produced in a pipe that is 1.20 m long. For the fundamental and first two overtones, determine the locations along the pipe (measured from the left end) of the displacement nodes and the pressure nodes if the pipe is closed at the left end and open at the right end.

## 1.2.2 Vibrating strings

The string is a tightly stretched wire or length of gut. When it is struck, bowed or plucked, progressive transverse waves travel to both ends, which are fixed, where they are reflected to meet the incident waves. A stationary wave pattern is formed for waves whose wavelengths fit into the length of the string, i.e. resonance occurs.

If you shake one end of a cord (slinky) and the other end is kept fixed, a

continuous wave will travel down to the fixed end and be reflected back, inverted. The frequencies at which standing waves are produced are the natural frequencies or resonant frequencies of the cord. A progressive sound wave (i.e. a longitudinal wave) is produced in the surrounding air with frequency equal to that of the stationary transverse wave on the string.

Now let consider a cord stretched between two supports that is plucked like a guitar or violin string. Waves of a great variety of frequencies will travel in both directions along the string, will be reflected at the ends, and will be travel back in the opposite direction. The ends of the string, since they are fixed, will be nodes.

The lowest frequency, called the **fundamental frequency**, corresponds to one antinode (or loop) and corresponds to whole length of the string i.e.,  $L = \frac{\lambda}{2}$  the other natural frequencies are called **overtone** or **harmonics**. The next mode after the fundamental has two loops and is called the second harmonic or first overtone and so on.

$$\text{Fundamental note (first harmonic): } L = \frac{\lambda}{2} \quad (1.13)$$

$$\text{The frequency } f = \frac{v}{\lambda} \Leftrightarrow f = \frac{v}{2L} \quad (1.14)$$

It was stated that the speed of a transverse wave travelling along a string is given by  $v = \sqrt{\frac{T}{\mu}}$

$$\text{The frequency of the vibration is given by: } f = \frac{1}{2L} \sqrt{\frac{T}{\mu}} \quad (1.15)$$

First overtone (second harmonic) of a string plucked in the middle corresponds to a stationary wave which has nodes at the fixed ends and antinode in the middle. If is  $\lambda_1$  the wave length it can be seen that:

$$L = \frac{3\lambda_1}{2} \Rightarrow \lambda_1 = \frac{2L}{3} \quad (1.16)$$

$$\text{The frequency of fist overtone is given by: } f_1 = \frac{c}{\lambda_1} = \frac{3}{2} \sqrt{\frac{T}{\mu}}$$

In order to find the frequency  $f$  of each vibration we use equation:  $f = \frac{c}{\lambda}$  and

we see that 
$$f_n = \frac{v}{\lambda_n} = nf_1 \tag{1.17}$$

where  $v = \sqrt{\frac{T}{\mu}}$  and  $f_1 = \frac{1}{2L} \sqrt{\frac{T}{\mu}}$  (1.18)

Consider a string of length  $L$  fixed at both ends, as shown in Fig.1.12. Standing waves are set up in the string by a continuous superposition of wave incident on and reflected from the ends.

Note that there is a boundary condition for the waves on the string. The ends of the string, because they are fixed, must necessarily have zero displacement and are, therefore, **nodes** by definition.

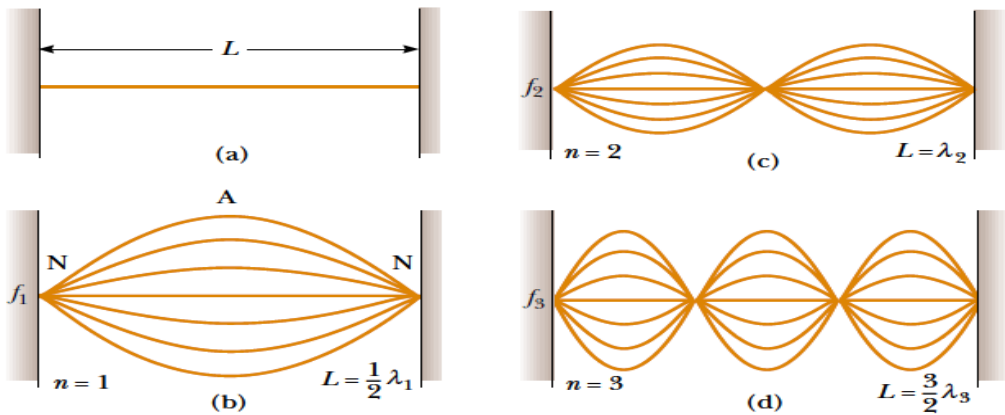

Fig.1. 13: Fundamental and first two overtones: (a) A string of length  $L$  fixed at both ends.

The normal modes of vibration form a harmonic series: (b) the fundamental note (first harmonic); (c) First overtone (second harmonic); (d) the second overtone (third harmonic) (Halliday, Resneck, & Walker, 2007).

### Example 1.5

A piano string is 1.10 m long and has mass of 9 g.

- How much tension must the string be under if it is to vibrate at a fundamental frequency of 131 Hz?
- What are the frequencies of the first four harmonics?

Answer

- The wavelength of the fundamental frequency is  
 $\lambda = 2L = 2.20\text{m}$

The velocity is then  $v = \lambda f = (2.2)(131) = 288 \text{ m/s}$

Then from

$$v = \sqrt{\frac{T}{m}} = v^2 = \frac{TL}{m} \Leftrightarrow T = \frac{v^2 L}{m} = 679 \text{ N}$$

- The frequencies of second, third, and fourth harmonics are three, and four times the fundamental frequency: 262 Hz, 393 Hz, and 524 Hz.

Quick check 1.3:

Middle C on a piano has a fundamental frequency of 262 Hz, and the first A above middle C has a fundamental frequency of 440 Hz.

- Calculate the frequencies of the next two harmonics of the C string.
- If the A and C strings have the same linear mass density  $\mu$  and length  $L$ , determine the ratio of tensions in the two strings.
- With respect to a real piano, the assumption we made in (b) is only partially true. The string densities are equal, but the length of the A string is only 64 % of the length of the C string. What is the ratio of their tensions?

### 1.2.3. Wave Interference and Superposition

#### a. Wave interference

Up to this point we've been discussing waves that propagate continuously in the same direction. But when a wave strikes the boundaries of its medium, all or part of the wave is **reflected**.

When you yell at a building wall or a cliff face some distance away, the sound wave is reflected from the rigid surface and you hear an echo. When you flip the end of a rope whose far end is tied to a rigid support, a pulse travels the length of the rope and is reflected back to you. In both cases, the initial and reflected waves overlap in the same region of the medium. This overlapping of waves is called **interference**.

In general, the term “interference” refers to what happens when two or more waves pass through the same region at the same time Fig.1.14 shows an example of another type of interference that involves waves that spread out in space.

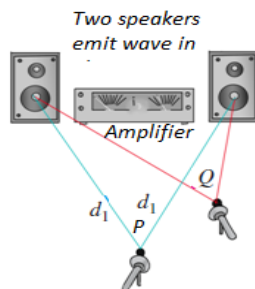

Fig.1. 14: Two speakers driven by the same amplifier: Constructive interference occurs at point  $P$  and destructive interference occurs at  $Q$ .

Two speakers, driven in phase by the same amplifier, emit identical sinusoidal sound waves with the same constant frequency. We place a microphone at point  $P$  in the figure, equidistant from the speakers. Wave crests emitted from the two speakers at the same time travel equal distances and arrive at point  $P$  at the same time; hence the waves arrive in phase, and there is constructive interference.

The total wave amplitude at  $P$  is twice the amplitude from each individual wave, and we can measure this combined amplitude with the microphone.

Now let’s move the microphone to point  $Q$ , where the distances from the two speakers to the microphone differ by a half-wavelength. Then the two waves arrive a half-cycle out of step, or *out of phase*; a positive crest from one speaker arrives at the same time as a negative crest from the other. Destructive interference takes place, and the amplitude measured by the microphone is much *smaller* than when only one speaker is present. If the amplitudes from the two speakers are equal, the two waves cancel each other out completely at point  $Q$ , and the total amplitude there is zero.

### b. The principle of superposition

Combining the displacements of the separate pulses at each point to obtain the actual displacement is an example of the principle of superposition: “When two waves overlap, the actual displacement of any point on the string at any time is obtained by adding the displacement the point would have if only the first wave were present and the displacement it would have if only the second wave were present”.

In other words, the wave function  $y(t, x)$  that describes the resulting motion in this situation is obtained by *adding* the two wave functions for the two separate waves:

$$y(t, x) = y_1(t, x) + y_2(t, x) \quad (1.19)$$

Where  $y_1(t, x) = A \sin(\omega t - kx + \phi_1)$  and  $y_2(t, x) = A \sin(\omega t - kx + \phi_2)$

These waves overlap and interfere.

The resultant wave as these waves overlap and interfere can write as

$$y(t, x) = y_1(t, x) + y_2(t, x) = 2 \cos\left(\frac{\phi_2 - \phi_1}{2}\right) \sin\left(\omega t - kx + \frac{\phi_2 + \phi_1}{2}\right) \quad (1.20)$$

As we saw with transverse waves, when two waves meet they create a third wave that is a combination of the other two waves. This third wave is actually the sum of the two waves at the points where they meet. The two original waves are still there and will continue along their paths after passing through each other. After passing the third wave no longer exists. Its amplitude has the

$$\text{magnitude } A_r = 2A \cos\left(\frac{\phi_2 - \phi_1}{2}\right) \quad (1.21)$$

## ACTIVITY 1.4:

### Problem 1

The Adventures of Marvin the Mouse: You and your friend are walking down by the pool when you hear a cry for help. Poor Marvin the Mouse has fallen into the pool and needs your help. The sides of the pool are too slippery for Marvin to climb out but there is an inner tube anchored in the center of the pool. Oh no! The sides of the inner tube are too slippery and high for Marvin to climb. He's getting tired and can't swim to the sides; he has just enough energy to float by the inner tube. Having studied about waves, you and your friend take up positions on opposite sides of the pool. How did you help Marvin get safely onto the inner tube?

### Problem 2: Dance club designer

You are the designer of a new Dance Club. You have been informed that you need to design the club in such a way that the telephone is placed in a location that allows the customers to hear the people on the other side. The phone company states that they can only put the phone line in at a point 20 m from the stage. Develop a model which allows the customers to use the phone with the least amount of trouble given that the phone must be placed at a distance of 20 m, ( $2/3$  the room size), from the stage. This will be an area where there will be virtually no sound.

### c. Resonance of sound

We have seen that a system such as a taut string is capable of oscillating in one or more normal modes of oscillation. If a periodic force is applied to such a system, the amplitude of the resulting motion is greater than normal when the frequency of the applied force is equal to or nearly equal to one of the natural frequencies of the system. This phenomenon is known as resonance. Although a block–spring system or a simple pendulum has only one natural frequency, standing-wave systems can have a whole set of natural frequencies.

Because oscillating systems exhibits large amplitude when driven at any of its natural frequencies, these frequencies are often referred to as resonance frequencies. Fig.1.15 shows the response of an oscillating system to various driving frequencies, where one of the resonance frequencies of the system is denoted by  $f_0$

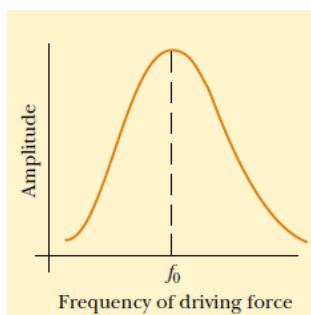

*Fig.1. 15: Graph of the amplitude versus driving frequency for oscillating system. The amplitude is a maximum at the resonance frequency. Note that the curve is not symmetric (Halliday, Resneck, & Walker, 2007)*

One of our best models of resonance in a musical instrument is a resonance tube. This is a hollow cylindrical tube partially filled with water and forced into vibration by a tuning fork (Fig.1.16). The tuning fork is the object that forced the air, inside the resonance tube, into resonance.

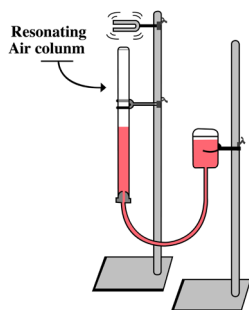

*Fig.1. 16: Turning fork forcing air column into resonance*

As the tines of the tuning fork vibrate at their own natural frequency, they create sound waves that impinge upon the opening of the resonance tube. These impinging sound waves produced by the tuning fork force air inside of the resonance tube to vibrate at the same frequency. Yet, in the absence of resonance, the sound of these vibrations is not loud enough to discern.

Resonance only occurs when the first object is vibrating at the natural frequency of the second object. So if the frequency at which the tuning fork vibrates is not identical to one of the natural frequencies of the air column inside the resonance tube, resonance will not occur and the two objects will not sound out together with a loud sound. But the location of the water level can be altered by raising and lowering a reservoir of water, thus decreasing or increasing the length of the air column.

So by raising and lowering the water level, the natural frequency of the air in the tube could be matched to the frequency at which the tuning fork vibrates.

When the match is achieved, the tuning fork forces the air column inside of the resonance tube to vibrate at its own natural frequency and resonance is achieved. The result of resonance is always a big vibration - that is, a loud sound.

A more spectacular example is a singer breaking a wine glass with her amplified voice. A good-quality wine glass has normal-mode frequencies that you can hear by tapping it.

If the singer emits a loud note with a frequency corresponding exactly to one of these normal-mode frequencies, large-amplitude oscillations can build up and break the glass (Fig. 1.17)



*Fig. 1. 17: Some singers can shatter a wine glass by maintaining a certain frequency of their voice for seconds, (a) Standing-wave pattern in a vibrating wine glass. (b) A wine glass shattered by the amplified sound of a human voice*

#### **d. Beats and its phenomena**

Beats occur when two sounds-say, two tuning forks- have nearly, but not exactly, the same frequencies interfere with each other. A crest may meet a trough at one instant in time resulting in destructive interference. However at later time the

crest may meet a crest at the same point resulting in constructive interference. To see how beats arise, consider two sound waves of equal amplitudes and slightly different frequencies as shown on the figure below.

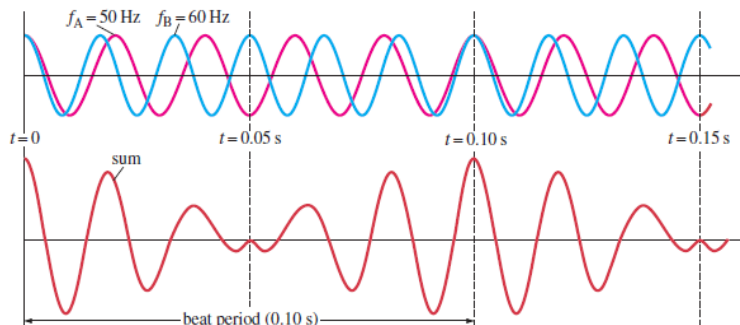

Fig.1. 18: Beats occur as a result of the superposition of two sound waves of slightly different frequencies (Cutnell & Johnson, 2006).

In 1.00 s, the first source makes 50 vibrations whereas the second makes 60. We now examine the waves at one point in space equidistant from the two sources. The waveforms for each wave as a function of time, at a fixed position, are shown on the top graph of Fig. 1.19; the red line represents the 50 Hz wave, and the blue line represents the 60 Hz wave. The lower graph in Fig. 1.18 shows the sum of the two waves as a function of time. At the time the two waves are in phase they interfere constructively and at other time the two waves are completely out of phase and interfere destructively. Thus the resultant amplitude is large every 0.10 s and drops periodically in between. This rising and falling of the intensity is what is heard as beats. In this case the beats are 0.10 s apart. The beat frequency is equal to the difference in frequencies of the two interfering waves.

Consider two sound waves of equal amplitude traveling through a medium with slightly different frequencies  $f_1$  and  $f_2$  at chosen point  $x = 0$ :

$$y_1 = A \cos 2\pi f_1 t \text{ and } y_2 = A \cos 2\pi f_2 t$$

Using the superposition principle, we find that the resultant wave function at this point is  $y = y_1 + y_2 = A(\cos 2\pi f_1 t + \cos 2\pi f_2 t)$

The trigonometric identity  $\cos a + \cos b = 2 \cos\left(\frac{a-b}{2}\right) \cos\left(\frac{a+b}{2}\right)$  allows us to write the expression for  $y$  as  $y = y_1 + y_2 = 2A \cos 2\pi\left(\frac{f_1 - f_2}{2}\right)t \cos 2\pi\left(\frac{f_1 + f_2}{2}\right)t$

We see that the resultant sound for a listener standing at any given point has an effective frequency equal to the average frequency  $\frac{f_1 + f_2}{2}$  and amplitude

given by the expression:  $A_{\max} = 2A \cos 2\pi \left( \frac{f_1 - f_2}{2} \right) t$  (1.22)

The frequency of the beats is equal to the difference in the frequencies of the two sound waves:

$$\text{beat frequency} = \text{frequency of loud sound heard} = f_1 - f_2 \quad (1.23)$$

The interference pattern varies in such a way that a listener hears an alternation between loudness and softness. The variation from soft to loud and back to soft is called a Beat. The phenomena of beats can be used to measure the unknown frequency of a note.

### Example 1.6

Two identical piano strings of length 0.750 m are each tuned exactly to 440 Hz. The tension in one of the strings is then increased by 1.0%. If they are now struck, what is the beat frequency between the fundamentals of the two strings?

**Answer:**

We find the ratio of frequencies if the tension in one string is 1.0% larger

than the other:  $\frac{f_2}{f_1} = \frac{\frac{v_2}{2L}}{\frac{v_1}{2L}} = \frac{v_2}{v_1} = \frac{\sqrt{\frac{T_2}{\mu}}}{\sqrt{\frac{T_1}{\mu}}} = \sqrt{\frac{T_2}{T_1}} = \sqrt{\frac{1.010T_1}{T_1}} = 1.005$  Thus,

the frequency of the tightened string is  $f_2 = 1.000 f_1 = 1.05 \times 400 = 442 \text{ Hz}$   
and the beat frequency is  $f_{\text{beat}} = 442 - 440 = 2 \text{ Hz}$

#### Quick check 1.4:

A tuning fork produces a steady 400 Hz tone. When this tuning fork is struck and held near a vibrating guitar string, twenty beats are counted in five seconds. What are the possible frequencies produced by the guitar string?

### 1.2.4 Checking my progress

1. Is the wavelength of the fundamental standing wave in a tube open at both ends greater than, equal to, or less than the wavelength of the fundamental standing wave in a tube with one open end and one closed end?

- You blow across the opening of a bottle to produce a sound. What must be the approximate height of the bottle for the fundamental note to be a middle C (1.29 m)?
- Two loudspeakers are separated by 2.5 m. A person stands at 3.0 m from one and at 3.5 m from the other one. Assume a sound velocity of 343 m/s. What is the minimum frequency to present destructive interference at this point? Calculate the other two frequencies that also produce destructive interference.
- How would you create a longitudinal wave in a stretched spring? Would it be possible to create a transverse wave in a spring?
- In mechanics, massless strings are often assumed. Why is this not a good assumption when discussing waves on strings?
- Draw the second harmonic (The second lowest tone it can make.) of a one end fixed, one end open pipe. Calculate the frequency of this mode if the pipe is 53.2 cm long, and the speed of sound in the pipe is 317 m/s.
- Calculate the wavelengths below. The length given is the length of the waveform (The picture)

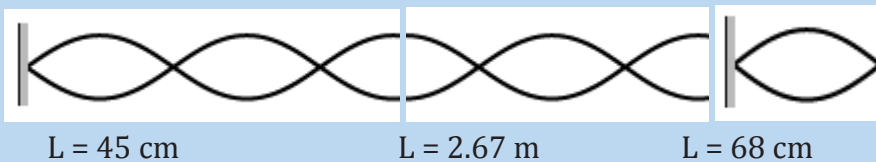

- A guitar string is 64 cm long and has a fundamental Mi frequency of 330 Hz. When pressing in the first fret (nearest to the tuning keys) see fig. the string is shortened in such a way that it plays a Fa note having a frequency of 350 Hz. Calculate the distance between this first fret and the nut necessary to get this effect.



- Why is a pulse on a string considered to be transverse?
- A guitar string has a total length of 90 cm and a mass of 3.6 g. From the bridge to the nut there is a distance of 60 cm and the string has a tension of 520 N. Calculate the fundamental frequency and the first two over tones

## 1.3 CHARACTERISTICS OF MUSICAL NOTES

### ACTIVITY 1.5: Characteristics of musical notes

The physical characteristics of a sound wave are directly related to the perception of that sound by a listener. Before you read this section answer these questions. As you read this section answer again these questions. Compare your answer.

1. What is the difference between the sound of whistle and that of drum?
2. Can you tell which musical instrument is played if the same note is played on different instrument without seeing it? Explain
3. How can you calculate the intensity of a sound wave?

A **musical note** is produced by vibrations that are regular and repeating, i.e. by periodic motion. Non-periodic motion results in **noise** which is not pleasant to the ear. Many behaviors of musical note can be explained using a few characteristics: intensity and loudness, frequency and pitch, and quality or timber.

#### 1.3.1. Pitch and frequency

The sound of a whistle is different from the sound of a drum. The whistle makes a high sound. The drum makes a low sound. The highness or lowness of a sound is called its pitch. The higher the frequency, the higher is the pitch. The frequency of an audible sound wave determines how high or low we perceive the sound to be, which is known as pitch.

Frequency refers to how often something happens or in our case, the number of periodic, compression-rarefaction cycles that occur each second as a sound wave moves through a medium and is measured in Hertz (Hz) or cycles/second. The term pitch is used to describe our perception of frequencies within the range of human hearing.

If a note of frequency 300 Hz and note of 600 Hz, are sounded by a siren, the pitch of the higher note is recognized to be an upper octave of the lower note. The musical interval between two notes is an upperoctave if the ratio of their frequencies is 2:1. It can be shown that the musical interval between two notes depends on the ratio of their frequencies, and not on the actual frequencies.

Whether a sound is high-pitched or low-pitched depends on how fast something vibrates. Fast vibrations make high-pitched sounds. Slow vibrations make low-pitched sounds.

Do not confuse the term pitch with frequency. Frequency is the physical measurement of the number of oscillations per second. Pitch is a psychological reaction to sound that enables a person to place the sound on a scale from high to low, or from treble to bass. Thus, frequency is the stimulus and pitch is the response. Although pitch is related mostly to frequency, they are not the same. A phrase such as “the pitch of the sound” is incorrect because pitch is not a physical property of the sound. The octave is a measure of musical frequency.

### 1.3.2 Intensity and amplitude

A police siren makes a loud sound. Whispering makes a soft sound. Whether a sound is loud or soft depends on the force or power of the sound wave. Powerful sound waves travel farther than weak sound waves. To talk to a friend across the street you have to shout and send out powerful sound waves. Your friend would never hear you if you whispered.

A unit called the decibel measures the power of sound waves. The sound waves of a whisper are about 10 decibels. Loud music can have a level of 120 decibels or more. Sounds above 140 decibels can actually make your ears hurt. The energy carried by a sound wave is proportional to the square of its amplitude. The energy passing a unit area per unit time is called the intensity of the wave. The intensity of spherical sound wave at a place p is defined as the energy per second per m<sup>2</sup>, or power per m<sup>2</sup> flowing normally through an area at X. i.e

$$I = \frac{E/t}{A} = \frac{P}{4\pi r^2} \quad (1.25)$$

So the unit of intensity is  $W/m^2$  where r is the distance from the source for a spherical wave

#### Example 1.7

If the intensity of an earth-quake P wave 100 km from the source is  $I = 1.0 \times 10^6 W/m^2$ , what is the intensity 400 km from the source?

Answer

$$\text{Power: } P = 4I_1\pi r_1^2 = 4I_2\pi r_2^2 \Leftrightarrow I_2 = I_1 \frac{r_1^2}{r_2^2} = 6.2 \times 10^4 W/m^2$$

#### Sound intensity level

To the human ear the change in loudness when the power of a sound increases from 0.1 W to 1.0 W is the same as when 1 W to 10 W. The ear responds to the

ratio of the power and not to their difference. We measure sound level intensity in terms of “decibels”. The unit bel is named after the inventor of the telephone, Alexander Graham Bell (1847–1922). The decibel is a “relative unit” which is actually dimensionless, comparing a given sound to a standard intensity which

represents the smallest audible sound: 
$$\beta = 10 \log \frac{I}{I_0} \quad (1.26)$$

Where  $I_0 = 10^{-12} \text{ W / m}^2$  at 1000 Hz is the reference intensity. 0 dB thus represents the softest audible sound (threshold of human hearing), while 80 dB (i.e., moderately loud music) represents an intensity which is one hundred million times greater.

### Example 1.8

Two identical machines are positioned the same distance from a worker. The intensity of sound delivered by each machine at the location of the worker is . Find the sound level heard by the worker (a) when one machine is operating and (b) when both machines are operating.

Answer

- a. The sound level at the location of the worker with one machine operating is

$$\beta_1 = 10 \log \frac{2.0 \times 10^{-7} \text{ W / m}^2}{1.00 \times 10^{-12} \text{ W / m}^2} = 53 \text{ dB}$$

- b. When both machines are operating, the intensity is doubled to ; therefore, the sound level now is

$$\beta_2 = 10 \log \frac{4.0 \times 10^{-7} \text{ W / m}^2}{1.00 \times 10^{-12} \text{ W / m}^2} = 56 \text{ dB}$$

From these results, we see that when the intensity is doubled, the sound level increases by only 3 dB.

#### Quick check 1.4:

A point source emits sound waves with an average power output of 80.0 W.

- Find the intensity 3.00 m from the source.
- Find the distance at which the sound level is 40 dB.

### ACTIVITY 1.6: Noise or music

Most people like to listen to music, but hardly anyone likes to listen to noise.

- What is the physical difference between musical sound and noise?
- What is the effect of noise to human being?

The physical characteristics of a sound wave are directly related to the perception of that sound by a listener. For a given frequency the greater the pressure amplitude of a sinusoidal sound wave, the greater the perceived loudness. The loudness or softness of sound depends on the intensity of the sound wave reaching the person concerned. Loudness is a subjective quantity unlike intensity. Sound that is not wanted or unpleasant to the ear is called noise. High intensity can damage hearing. The higher the intensity, the louder is the sound. Our ears, however, do not respond linearly to the intensity. A wave that carries twice the energy does not sound twice as loud.

### 1.3.3 Quality or timbre

If the same note is sounded on the violin and then on the piano, an untrained listener can tell which instrument is being used, without seeing it. We would never mistake a piano for flute. We say that the quality or timbre of note is different in each case. The manner in which an instrument is played strongly influences the sound quality. Two tones produced by different instruments might have the same fundamental frequency (and thus the same pitch) but sound different because of different harmonic content. The difference in sound is called tone color, quality, or timbre. A violin has a different timbre than a piano.

### 1.3.4 Checking my progress

1. Complete each of the following sentences by choosing the correct term from the word bank: loudness, pitch, sound quality, echoes, intensity and noise
  - a. The ----- of a sound wave depends on its amplitude
  - b. Reflected sound waves are called -----
  - c. Two different instruments playing the same note sound different because of -----
2. Plane sound wave of frequency  $100\text{ Hz}$  fall normally on a smooth wall. At what distances from the wall will the air particles have:
  - a. Maximum
  - b. Minimum amplitude of vibration?

Give reasons for your answer. The speed of sound in air may be taken as  $340\text{ m/s}$
3. A boy whistles a sound with the power of  $0.5 \times 10^{-4}\text{ W}$ . What will be his sound intensity at a distance of  $5\text{ m}$ ?
4. Calculate the intensity level equivalent to an intensity  $1\text{ nW/m}^2$
5. If the statement is true, write true. If it is false, change the underlined word or words to make the statement true.
  - a. **Intensity** is mass per unit volume.
  - b. **Loudness** is how the ear perceives frequency
  - c. **Music** is a set of notes that are pleasing

## 1.4 APPLICATIONS OF SOUND WAVES

### ACTIVITY 1.7: Doppler Effect and uses of sound waves

1. Why does the pitch of a siren change as it moves past you?
2. How is Doppler's effect used in communication with satellites?
3. Explain how is the Doppler's effect used in Astronomy?
4. People use sound for other things other than talking and making music. In your own word, give more examples and explanations to support this statement.

#### 1.4.1 The Doppler Effect

Doppler's effect is the apparent variation in frequency of a wave due to the relativemotion of the source of the wave and the observer.



Fig.1. 19 C.J.Doppler (Douglass, PHYSICS, Principles with applications., 2014)

The effect takes its name from the Austrian Mathematician Christian Johann Doppler (1803-1853), who first stated the physical principle in 1842. Doppler's principle explains why, if a source of sound of a constant pitch is moving toward an observer, the sound seems higher in pitch, whereas if the source is moving away it seems lower. This change in pitch can be heard by an observer listening to the whistle of an express train from a station platform or another train.

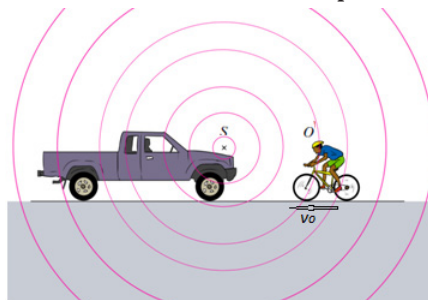

Fig.1. 20: An observer  $O$  (the cyclist) moves with a speed  $v_o$  toward a stationary point source  $S$ , the horn of a parked truck. The observer hears a frequency  $f'$  that is greater than the source frequency.

When the source of the wave approaches detector (observer) at speed  $v_s$ ,

The wavelength is shortened by an amount  $v_s T$ , where  $T$  is the period of the wave. This is simply due to the motion of the source. Since the “received” wavelength ( $\lambda_r$ ) is related to the “source” wavelength by ( $\lambda_s$ )

$$\lambda_r = \lambda_s - v_s T = \lambda_s \left( \frac{v - v_s}{v} \right)$$

Knowing the velocity of the moving source of wave ( $v_s$ ), you can use the equation  $v = \lambda f$  to convert the wavelength equations to solve for frequency.

The received frequency is related to the source frequency by

$$f_r = f_s \frac{v}{v - v_s} \quad (1.27)$$

Hence the frequency you hear is higher than the frequency emitted by the approaching source.

### Example 1.9

If a source emits a sound of frequency 400 Hz when at rest, then when the source moves toward a fixed observer with a speed of 30 m/s, what frequency does the observer hear knowing that the speed of a sound in air at room temperature is 343m/s?

Answer

$$\text{The observer hears a frequency of } f_r = 400 \frac{343}{343 + 30} = 434 \text{ Hz}$$

As the source passes you and recedes, the “speed of approach”  $v_s$  becomes negative, and the frequency you hear becomes lower than the frequency emitted by the now receding source.

$$\text{The frequency of the wave will be: } f_r = f_s \frac{v + v_0}{v} \quad (1.28)$$

In this case if a source vibrating at 400 Hz is moving away from a fixed observer

$$\text{at 30 m/s, the later will hear a frequency of about } \lambda_r = 400 \frac{343}{343 + 30} = 434 \text{ Hz}$$

#### a. When the source is stationary but you are approaching it at a speed $v_o$ .

The Doppler’s effect also occurs when the source is at rest and the observer is in motion. If the observer is travelling toward the source the pitch is higher; and if the observer is travelling away from the source, the pitch is lower.

With a fixed source and moving observer, the distance between wave crests, the wavelength  $\lambda$ , is not changed. But the velocity of the crests with respect to the observer is changed. If the observer is moving toward the source, the speed of the wave relative to the observer is  $v' = v + v_0$

$$\text{Hence, the new frequency is } f_r = f_s \frac{v + v_0}{v} \quad (1.29)$$

If the observer is moving away from the source, the relative velocity is  $v' = v - v_0$  and  $f_r = f_s \frac{v - v_0}{v}$  (1.30)

### Example 1.10

1. The siren of a police car at rest emits at a predominant frequency of 1600 Hz. What frequency will be heard if you were moving with speed of 25 m/s?
  - a. Toward it?
  - b. Away from it?

#### Answer

a. We use equation  $f_r = f_s \left( \frac{v + v_0}{v} \right) = 1600 \left( \frac{343 + 25}{343} \right) = 1716.6 \text{ Hz}$

b. We use equation:  $f_r = f_s \left( \frac{v - v_0}{v} \right) = 1600 \left( \frac{343 - 25}{343} \right) = 1483 \text{ Hz}$

#### b. If both the source and receiver are moving

If both the source and receiver are moving and  $v_s$  and  $v_o$  are the speeds with which they are approaching each other (respectively), the Doppler shift is

$$f_r = f_s \frac{v + v_o}{v - v_s} \quad (1.31)$$

c. Here  $v$  is the speed of sound in air;  $v_r$  is the speed of the listener (substituted as positive if he moves towards the source, as negative if he moves away from the source), and  $v_s$  is the speed of the source (reckoned as positive if it moves towards the listener, as negative if it moves away from the listener).

### Example 1.11

A car, sounding a horn producing a note of 500 Hz, approaches and passes a stationary observer O at a steady speed of 20 m/s. Calculate the change in pitch of the note heard by O (speed of sound is 340 m/s)

**Answer:**

Towards O, apparent frequency to O:  $f' = 500 \frac{340}{340 - 20} = 531 \text{ Hz}$

Away from O, the apparent frequency to O:  $f'' = 500 \frac{340}{340 + 20} = 472 \text{ Hz}$

Change in pitch:  $\frac{f''}{f'} = 0.9$

For convenience, we can write Doppler's effect equation as a single equation that covers all cases of both source and observer in motion:

$$f_r = f_s \frac{v \pm v_o}{v \mp v_s} \quad (1.32)$$

The upper signs apply if source and/or observer move toward each other. The lower signs apply if they are moving apart. The word toward is associated with an increase in observed frequency. The words away from are associated with a decrease in observed frequency. Although the Doppler's effect is most typically experienced with sound waves, it is a phenomenon that is common to all waves. For example, the relative motion of source and observer produces a frequency shift in light waves. The Doppler's effect is used in police radar systems to measure the speeds of motor vehicles. Likewise, astronomers use the effect to determine the speeds of stars, galaxies, and other celestial objects relative to the Earth.

### Example 1.12

As an ambulance travels east down a highway at a speed of 33.5 m/s, its siren emits sound at a frequency of 400 Hz. What frequency is heard by a person in a car traveling west at 54.6 m/s

- As the car approaches the ambulance and
- As the car moves away from the ambulance?

**Answer**

As the ambulance and car approach each other, the person in the car hears the frequency

$$f_r = \frac{v + v_o}{v - v_s} f_s = \left( \frac{343 \text{ m/s} + 24.6 \text{ m/s}}{343 \text{ m/s} - 33.5 \text{ m/s}} \right) \times 400 \text{ Hz} = 475 \text{ Hz}$$

a. As the vehicles recede from each other, the person hears the frequency

$$f_r = \frac{v - v_0}{v + v_0} f_s = \left( \frac{343 \text{ m/s} - 24.6 \text{ m/s}}{343 \text{ m/s} + 33.5 \text{ m/s}} \right) \times 400 \text{ Hz} = 475 \text{ Hz}$$

The change in frequency detected by the person in the car is  $475 \text{ Hz} - 338 \text{ Hz} = 137 \text{ Hz}$ , which is more than 30% of the true frequency.

b. Suppose the car is parked on the side of the highway as the ambulance speeds by. What frequency does the person in the car hear as the ambulance (a) approaches and (b) recedes?

**Answer**

(a) 443 Hz.

(b) 364 Hz.

The motion of the source of sound affects its pitch.

Quick check 1.5:

Middle C on the musical scale has a frequency of 264 Hz. What is the wavelength of the sound wave?

### 1.4.2 Uses of Ultrasonic

#### a. Echolocation

Some marine mammals, such as dolphin, whales, and porpoises use sound waves to locate distant objects. In this process, called **echolocation**, a dolphin produces a rapid train of short sound pulses that travel through the water, bounce off distant objects, and reflect back to the dolphin. From these echoes, dolphins can determine the size, shape, speed, and distance of their potential prey. Experiments have shown that at distance of 114 m, a blindfolded dolphin can locate a stainless-steel sphere with a diameter of 7.5 cm and can distinguish between a sheet of aluminum and a sheet of copper (Cutnell & Johnson, 2006).

The Ultrasonic waves emitted by a dolphin enable it to see through bodies of other animals and people (Fig.1.21). Skin muscles and fat are almost transparent to dolphins, so they see only a thin outline of the body but the bones, teeth and gas-filled cavities are clearly apparent. Physical evidence of cancers, tumors, heat attacks, and even emotional shake can all be seen by dolphin. What is more interesting, the dolphin can reproduce the sonic signals that paint the mental image of its surroundings, and thus the dolphin probably communicates its experience to other dolphins. It needs no words or symbol for fish, for example,

but communicates an image of the real thing.

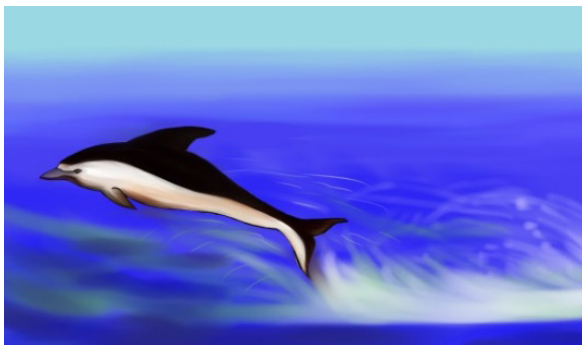

*Fig.1. 21: The Ultrasonic waves emitted by a dolphin enable it to see through bodies of other animals and people.*

Bats also use echo to navigate through air. Bats use ultrasonic with frequencies up to 100 kHz to move around and hunt (Fig.1.23).

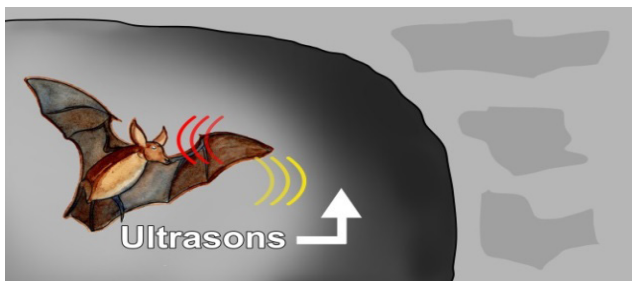

*Fig.1. 22 Bats use ultrasonic with frequencies up to 100 kHz to move around and hunt.*

The waves reflect off objects and return to the bat's ears. The time it takes for the sound waves to return tells the bat how far it is from obstacles or prey. The bat uses the reflected sound waves to build up a picture of what lies ahead. Dogs, cats and mice can hear ultrasound frequencies up to 450 kHz. Some animals not only hear ultrasound but also use ultrasonic to see in dark.

### **b. In medicine**

The sonogram is a device used in medicine and exploits the reflected ultrasound to create images. This **pulse-echo technique** can be used to produce images of objects inside the body and is used by Physicians to observe fetuses. Ultrasound uses a high frequency in the range of 1 MHz to 10 MHz that is directed into the body, and its reflections from boundaries or interfaces between organs and other structures and lesions in the body are then detected. (Michael, Loannis, & Martha, 2006)

Tumors and other abnormal growths can be distinguished; the action of heart valves and the development of a foetus (Fig.1.24) can be examined; and information about various organs of the body, such as the brain, heart, liver, and kidneys, can be obtained.

Although ultrasound does not replace X-rays, for certain kinds of diagnosis it is more helpful. Some tissues or fluid are not detected in X-ray photographs, but ultrasound waves are reflected from their boundaries. Echoes from ultrasound waves can show what is inside the body. Echo is a reflection of sound off the surface of an object.

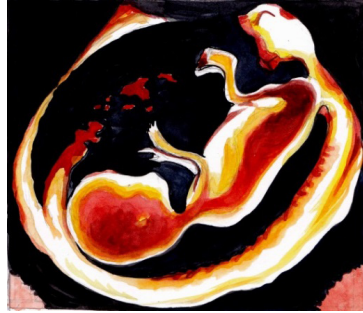

*Fig.1. 23: Ultrasound image as an example of using high-frequency sound waves to see within the human body (Douglass, PHYSICS, Principles with applications., 2014).*

In medicine, ultrasonic is used as a diagnostic tool, to destroy diseased tissue, and to repair damaged tissue. Ultrasound examination of the heart is known as echocardiography.

### **c. Sonar**

The **sonar** or pulse-echo technique is used to locate underwater objects and to determine distance. A transmitter sends out a sound pulse through the water, and a detector receives its reflection, or echo, a short time later. This time interval is carefully measured, and from it the distance to the reflecting object can be determined since the speed of sound in water is known. The depth of the sea and the location of sunken ships, submarines, or fish can be determined in this way. Sonar also tells how fast and what direction things are moving. Scientists use sonar to make maps of the bottom of the sea. An analysis of waves reflected from various structures and boundaries within the Earth reveals characteristic patterns that are also useful in the exploration for oil and minerals.

*Radar* used at airports to track aircraft involves a similar pulse-echo technique except that it uses electromagnetic (EM) waves, which, like visible light, travel with a speed of  $3 \times 10^8$  m/s.

One reason for using ultrasound waves, other than the fact that they are inaudible, is that for shorter wavelengths there is less diffraction so the beam spreads less and smaller objects can be detected.

#### **1.4.3 Uses of infrasonic**

Elephants use infrasonic sounds waves to communicate with one another. Their large ears enable them to detect these low frequency sound waves which have relatively long wavelengths. Elephants can effectively communicate in this way

even when they are separated by many kilometers. Some animals, such as this young bat-eared fox, have ears adapted for the detection of very weak sounds.



*Fig.1. 24: Some animals, such as this young bat-eared fox, have ears adapted for the detection of very weak sounds.*

#### **1.4.4 Checking my progress**

For question 1 to 2: Choose the letter of the best answer

1. Bats can fly in the dark without hitting anything because
  - a. They are flying mammals
  - b. Their night vision is going
  - c. They are guided by ultrasonic waves produced by them
  - d. Of no scientific reason
  
2. Bats and dolphins use echolocation to determine distances and find prey.  
What characteristic of sound waves is most important for echolocation?
  - a. Sound waves reflect when they hit a surface
  - b. Sound waves spread out from a source
  - c. Sound waves diffract around corner
  - d. Sound waves interfere when they overlap
  
3. Discuss application of sound waves in medicine and navigation
  
4. Explain how sonar is used to measure the depth of a sea
  
5. a. What is meant by Doppler Effect?  
b. A police car sound a siren of 1000 Hz as it approaches a stationary observer at a speed of 33.5 m/s. What is the apparent frequency of the siren as heard by the observer if the speed of sound in air is 340 m/s.  
c. Give one application of the Doppler Effect.

## END UNIT ASSESSMENT 1

### A. Multiple choices question

**For question 1 to 6, choose the letter of the best answer**

1. Which of the following affects the frequency of wave?
  - a. Reflection
  - b. Doppler effect
  - c. Diffraction
  - d. All of the above
  
2. Consider the following statements:
  - I. Recording of sound on tapes was first invented by Valdemar Poulsen.
  - II. Audio tapes have magnetic property.
  - III. The tapes may also be made of PVC (Polyvinyl-chloride)Of these statements:
  - a. I, II, and III all are correct.
  - b. I, II, and III all are wrong
  - c. I and II are correct, III is wrong
  - d. I and II are wrong, III is correct
  
3. Nodes are
  - a. Positions of maximum displacement
  - b. Positions of no displacement
  - c. A position between no displacement and maximum displacement
  - d. None of these
  
4. Sound waves are
  - a. Transverse waves characterized by the displacement of air molecules.
  - b. Longitudinal waves characterized by the displacement of air molecules.
  - c. Longitudinal waves characterized by pressure differences.
  - d. Both (B) and (C).
  - e. (A), (B), and (C).
  
5. In which of the following is the wavelength of the lowest vibration mode the same as the length of the string or tube?
  - a. A string.
  - b. A tube closed at one end.
  - c. All of the above.
  - d. An open tube.
  - e. E. None of the above.

6. When a sound wave passes from air into water, what properties of the wave will change?
  - a. Frequency.
  - b. Wave speed.
  - c. Both frequency and wavelength.
  - d. Wavelength.
  - e. Both wave speed and wavelength.

## B. Structured questions

1. Does the phenomenon of wave interference apply only to sinusoidal waves? Explain.
2. As oppositely moving pulses of the same shape (one upward, one downward) on a string pass through each other, there is one instant at which the string shows no displacement from the equilibrium position at any point. Has the energy carried by traveling in opposite directions on the same string reflect from each other? Explain.
4. When two waves interfere, can the amplitude of the resultant wave be greater than the amplitude of any of the two original waves? Under which conditions?
5. When two waves interfere constructively or destructively, is there any gain or loss in energy? Explain.
6. Explain why your voice seems to sound better than usual when you sing in the shower.
7. An airplane mechanic notices that the sound from a twin-engine aircraft rapidly varies in loudness when both engines are running. What could be causing this variation from loud to soft?
8. Explain how a musical instrument such as a piano may be tuned by using the phenomenon of beats.
9. Fill in the gap
  - a. As a sound wave or water ripple travels out from its source, its ----- decreases.
  - b. The vibrating air in a/an ----- has displacement antinodes at both ends.
  - c. For a /an ....., the fundamental corresponds to a wavelength four times the length of the tube.
  - d. The ..... refers to the change in pitch of a sound due to the motion either of the source or of the observer. If source and observer are approaching each other, the perceived pitch is ..... If they are moving apart, the perceived pitch is .....

10. A bat, moving at 5.00 m/s, is chasing a flying insect. If the bat emits a 40.0 kHz chirp and receives back an echo at 40.4 kHz, at what speed is the insect moving toward or away from the bat? (Take the speed of sound in air to be  $v = 340$  m/s.)
11. If you hear the horn of the car whose frequency is 216 Hz at a frequency of 225 Hz, what is their velocity? Is it away from you or toward you? The speed of sound is 343 m/s
12. You run at 12.5 m/s toward a stationary speaker that is emitting a frequency of 518 Hz. What frequency do you hear? The speed of sound is 343 m/s
13. If you are moving and you hear the frequency of the speaker at 557 Hz, what is your velocity? Is it away from or toward the speaker? The speed of sound is 343 m/s

### C. Essay type question

#### 20. Read the following text and answer the question

Researchers have known for decades that whales sing complicated songs. Their songs can last for 30 min and a whale may repeat the song for two or more hours. Songs can be heard at a distances of hundreds of kilometers. There is evidence that whales use variations in the songs to tell other whales about the location of food and predators. Only the male whales sing, which has led some researchersto think that songs are also used to attract a male.

The whale songs may be threatened by noise pollution. in the past 50 years, ocean noise has increased due to human activities. Goods are transported across the ocean in larger ships than ever before. Large ships use bigger engines. They produce low-frequency noise by stirring up air bubbles with their propellers. Unfortunately, whales also use low-frequency sound in their songs, perhaps because these sounds carry further than high-frequency sounds in the ocean. Propeller noise from large ships is loud enough to interfere with whale songs at a distance of 20 km.

#### **Question: Are regulations needed to protect whales from noise?**

In your own words, describe the major issue that needs to be resolved about ocean noise pollution. List three arguments for those who think regulations should require large ships to reduce noise pollution. List three arguments for those who think regulations are not necessary.

# UNIT 2

## APPLICATION OF PHYSICS IN AGRICULTURE



*Fig.2. 1: A farmer spraying rice*

**Key unit competence:** Evaluate applications of Physics in Agriculture.

### **My goals**

- Describe the atmosphere and its constituents.
- Outline variation of atmospheric pressure, air density and water vapour with altitude.
- Evaluate how heat and mass transfers occur in the atmosphere.
- Apply knowledge of physics to illustrate changes in water vapour atmospheric pressure, and air with altitude.
- Evaluate and interpret physical properties of soil (soil Texture and structure).
- Evaluate why air, temperature and rainfall limit economical activities in Agriculture.
- Explaining how mechanical weathering and soil erosion impact economic activities in agriculture.
- Explaining clearly how agrophysics plays an important role in the limitation of hazards to agricultural objects and environment in our country.

## INTRODUCTORY ACTIVITY: Role of machines in agriculture

It is very important to know the role of Physics in agriculture and environment. Knowledge in physics can contribute more in the limitation of hazards in agriculture and the environment based on suitable programs of transformation and modernization of agriculture in our country.

Look at the image given in Fig.2.1

- What do you observe? Is there any application of prior knowledge of Physics learnt before applied on the image? Justify your answer?
- Can you suggest the role of machines in agriculture? How do they contribute in the rapid development of the country programs of transformation and modernization of agriculture? Knowing different stages of growing plants activities, suggest which stages mostly benefit the use of technology!

**Plan it!** To get started, brainstorm about your prior knowledge on applications of physics in agriculture and try to suggest answers to questions given above based on your understanding.

## 2.1 ATMOSPHERE AND ITS CONSTITUENTS

### 2.1.1 Atmosphere

#### ACTIVITY 2.1: How the atmosphere protect life on the earth

- Brainstorm and write short notes on constituents of atmosphere and explain clearly how the atmosphere of Earth protects life on earth.
- Why should you care about protecting the atmosphere and minimise the long-term changes in the climate?
- What can be the use of atmospheric knowledge in evaluating and improving agricultural activities?

The **atmosphere of earth** is the layer of gases, commonly known as air that surrounds the earth. This layer of gases is retained by Earth's gravity. The atmosphere of Earth protects life on Earth by absorbing **ultraviolet solar radiations that cause cancers and other diseases**, warming the surface through heat retention (greenhouse effect) and reducing **temperature** extremes between day and night. It also contain the oxygen which human beings, animals

and plants are using, The atmospheric knowledge can be helpful in **evaluating and improving** the quality of soils and agricultural products as well as the technological processes.

### 2.1.2 Composition of the Atmosphere

**The atmosphere** is composed of a mixture of several gases in differing amounts. The permanent gases whose percentages do not change from day to day are nitrogen, oxygen and argon. By volume, dry air contains 78.0% **nitrogen**, 21% **oxygen**, 0.9% **argon**, 0.04% **carbon dioxide**, and small amounts of other gases called trace gases 0.1% as shown in Fig.2.2

Gases like carbon dioxide, nitrous oxides, methane, and ozone are trace gases that account for about a tenth of one percent of the atmosphere.

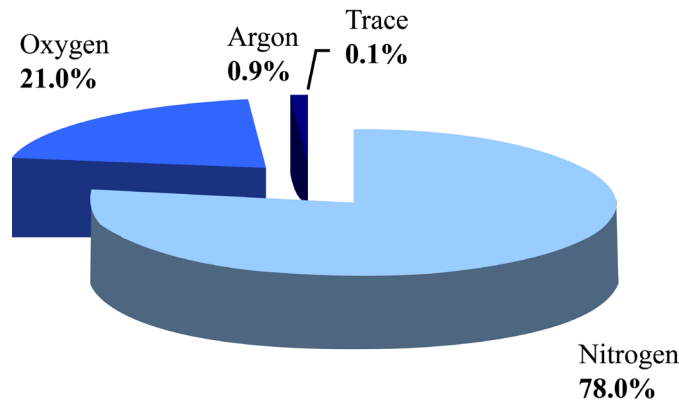

Fig.2. 2Composition of the atmosphere

Air also contains a variable amount of water vapor, on average around 1% at sea level, and 0.4% over the entire atmosphere. Water vapor is unique in that its concentration varies from 0-4% of the atmosphere depending on where you are and what time of the day it is. In the cold, dry Arctic regions water vapor usually accounts for less than 1% of the atmosphere, while in humid, tropical regions water vapor can account for almost 4% of the atmosphere. Water vapor content is very important in predicting weather.

Air content and atmospheric pressure vary at different layers, and air suitable for use in photosynthesis by terrestrial plants and breathing of terrestrial animals is found only in earth's troposphere.

The composition of the atmosphere, among other things, determines its ability to partly absorb and transmit sunlight radiations and trap infrared radiations, leading to potentially minimise the long-term changes in climate.

### 2.1.3 Layers of the atmosphere.

#### ACTIVITY 2.2: Classifying layers of the atmosphere

Materials For class demonstration:

- Chalk board or dry erase board mounted on a wall
- Chalk or dry erase marker
- 2-meter piece of string
- 1000 ml (1 litre) graduated cylinder
- Four bags of fish gravel or coloured sand (different colours)

#### Procedures

##### Case1:

1. Use a model to explore how far the earth's atmosphere extends above the surface of the earth and learn about the thickness of the different layers of the atmosphere.
2. How far do you think the atmosphere extends above us? Tie a dry eraser marker or a piece of chalk to one end of the string. Standing next to the board, place your foot on the free end of the string and draw an arc on the board with a radius of about 1.2 m. Your foot represents the center of the earth. The arc represents the surface of the Earth.

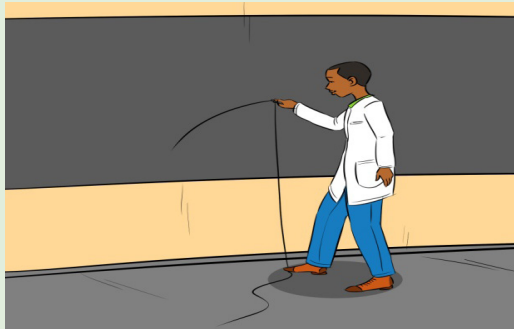

*Fig.2. 3 A person demonstrating the layers of the atmosphere*

3. Suggest how far the earth's atmosphere would extend above the surface in this drawing. Mark your suggestions on the board above the chalk/marker line. Note that it is found that over 90% of the earth's atmosphere is within about 12km of the earth's surface. The distance from the centre of the earth to its surface equals about 6361 km.

### Case 2:

1. Use a 1000 ml (1 liter) graduated cylinder and represent the layers by using the following amounts of fish gravel or coloured sand found in the photo and table below.
2. Choose what colour you want for each atmospheric layer. Keep in mind these are relative proportions and not exact points of departure for the different layers. In this scale model, each millilitre of volume represents one kilometre of atmosphere layer thickness (for example, the troposphere is 10 km thick and is represented by 10 ml of sand or gravel in the graduated cylinder).

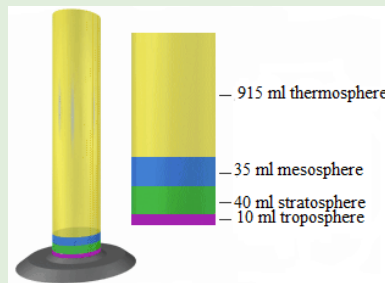

Fig.2. 4: Color coding represented in cylinder with the corresponding layers

Atmospheric Layer	Color Code	Thickness	Top of Layer
Troposphere	Color 1	10 ml	10
Stratosphere	Color 2	40 ml	50
Mesosphere	Color 3	35 ml	85
Thermosphere	Color 4	915 ml	1000

Table 2. 1: Atmospheric layers with color code and thickness

### Questions

1. What atmospheric layers are represented by the different colors?
2. What atmospheric layer do we live in?
3. How much thicker is the stratosphere compared to the troposphere?
4. How much thicker is the thermosphere compared to all the other layers combined?
5. Where in this model would you expect to find clouds?
6. Where in this model would you expect to find mounts Everest and Kalisimbi?
7. Where in this model would you expect to find a satellite?
8. Where in this model would you expect to find the space shuttle?
9. Where in this model is the ozone layer?

Earth's atmosphere has a series of layers, each with its own specific characteristics and properties. Moving upward from ground level, these layers are named the troposphere, stratosphere, mesosphere, thermosphere and exosphere.

The above activity demonstrates the relative thickness of the thin section of the atmosphere that includes the **troposphere and stratosphere**. These layers are essential to all life on Earth. Over 99% of the mass of the Earth's atmosphere is contained in the two lowest layers: the troposphere and the stratosphere. Most of the Earth's atmosphere (80 to 90%) is found in the troposphere, the **atmospheric layer where we live** (Cunningham & William, 2000).

This layer, where the Earth's weather occurs, is within about 10 km of the Earth's surface. The stratosphere goes up to about 50 km. Gravity is the reason why atmosphere is more dense closer to the Earth's surface.

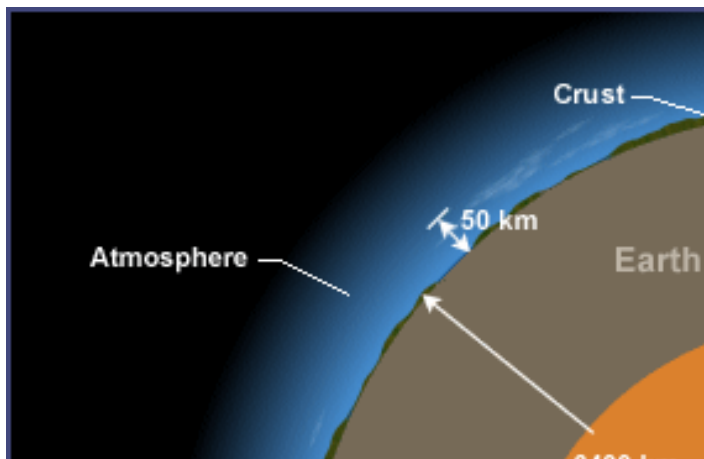

*Fig.2. 5: Illustration of layers from the core to the atmosphere*

While we may think of the atmosphere as a vast ocean of air around us, it is very thin relative to the size of the earth. The “thickness” of the atmosphere, or the distance between the earth's surface and the “top” of the atmosphere, is not an exact measure. Although air is considered as a fluid, it does not have the same well-defined surface as water does. The atmosphere just fades away into space with increasing altitude.

## **Description of layers of earth's atmosphere**

### **A. Troposphere**

This is the lowest layer of our atmosphere starting at ground level; it extends upward to about 10 km above the sea level. We live in the troposphere, and nearly all weather occurs in this lowest layer. Most clouds appear here, mainly because 99% of the water vapor in the atmosphere is found in the troposphere.

Air pressure drops and temperatures get colder, as you climb higher in the troposphere.

## **B. Stratosphere**

The stratosphere extends from the top of the troposphere to about 50 km above the ground. The infamous ozone layer is found within the stratosphere. Ozone molecules in this layer absorb high-energy ultraviolet (*UV*) light from the sun, converting the ultraviolet energy into heat.

Unlike the troposphere, the stratosphere actually gets warmer the higher you go! That trend of rising temperatures with altitude means that air in the stratosphere lacks the turbulence and updrafts of the troposphere beneath. Commercial passenger jets fly in the lower stratosphere, partly because this less-turbulent layer provides a smoother ride.

## **C. Mesosphere**

It extends upward to a height of about 85 km above our planet. Most meteors burn up in the mesosphere. Unlike the stratosphere, temperatures once again grow colder as you rise up through the mesosphere. The coldest temperatures in earth's atmosphere, about  $-90^{\circ}\text{C}$ , are found near the top of this layer. The air in the mesosphere is far too thin to breathe; air pressure at the bottom of this layer is well below 1% of the pressure at sea level, and continues dropping as you go higher.

## **D. Thermosphere**

High-energy X-rays and ultraviolet radiations from the Sun are absorbed in the thermosphere, raising its temperature to hundreds or at times thousands of degrees. Many satellites actually orbit Earth **within** the thermosphere! Variations in the amount of energy coming from the Sun exert a powerful influence on both the height of the top of this layer and the temperature within it. Because of this, the top of the thermosphere can be found anywhere between 500 km and 1 000 km above the ground. Temperatures in the **upper thermosphere** can range from about  $500^{\circ}\text{C}$  to  $2\,000^{\circ}\text{C}$  or even higher.

## **E. Exosphere**

Although some experts consider the thermosphere to be the uppermost layer of our atmosphere, others consider the **exosphere** to be the actual "final frontier" of Earth's gaseous envelope. As you might imagine, the "air" in the exosphere is very thin, making this layer even more space-like than the thermosphere.

In fact, air in the **exosphere** is constantly "leaking" out of earth's atmosphere into outer space. There is no clear-cut upper boundary where the exosphere

finally fades away into space. Different definitions place the top of the exosphere somewhere between 100 000 km and 190 000 km above the surface of earth. The latter value is about halfway to the moon!

## F. Ionosphere

The ionosphere is not a distinct layer like the others mentioned above. Instead, the ionosphere is a series of regions in parts of the mesosphere and thermosphere where high-energy radiation from the sun has ionized atoms and molecules. The ions formed in this way are responsible of the naming of this region as the ionosphere and endowing it with some special properties.

### ACTIVITY 2.3: Classifying layers of the atmosphere

Observe scale models of the atmosphere on fig.3.3 below and its layers. Note the height of earth's atmosphere as compared to the size of the planet overall and the relative thickness of each of the four main layers of the atmosphere. Interpret the graph and Use it to answer questions below:

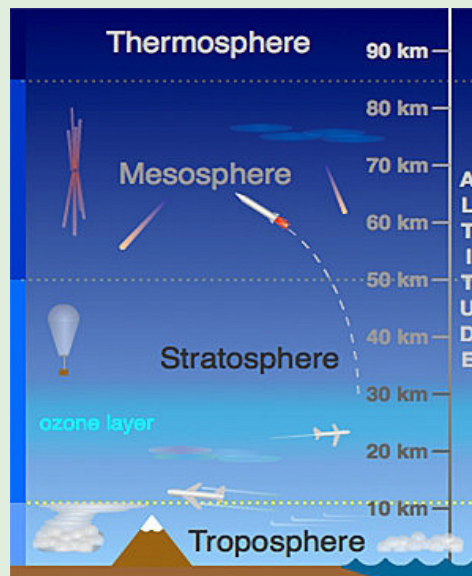

Fig.2. 6: Layers of the atmosphere.

Questions:

- Outline the economic activities taking place in the layers represented above?
- Why is it very important to have ozone layer in the layers close to the earth surface?
- Explain why it is advisable to travel in troposphere and stratosphere than in other layers of the atmosphere?
- Explain clearly why the rocket and aeroplanes decide to move in the corresponding layers of the atmosphere?

### 2.1.4 Checking my progress

1. Use the fruit question suggested in the procedure and respond in writing or with a picture instead of simply orally in class. Think of the fruit as the size of the Earth and the skin of the fruit represents the thickness of the atmosphere. Make a labelled diagram in your note book illustrating the most important point of the lesson and the reason why the atmosphere is considered as the skin of the fruit?
2. Imagine that you are in an orbit around a planet one half the size and mass of the Earth. Explain how I would expect the atmosphere of the new planet to be different from my planet?
3. What is the structure and composition of the atmosphere?
4. How does solar energy influence the atmosphere?
5. How does the atmosphere interact with land and oceans?
6. Outline two most important layers that are essential to all life on earth? Explain clearly to support your answer.

## 2.2 HEAT AND MASS TRANSFER

### 2.2.1 Modes of Heat Transfer

#### ACTIVITY 2.4: Describing the different modes of heat transfer in the atmosphere

Brainstorm on modes of heat transfer and explain clearly how each affects agricultural activities?

**Heat transfer** is concerned with the exchange of thermal energy through a body or between bodies which occurs when there is a temperature difference. When two bodies are at different temperatures, thermal energy transfers from the one with higher temperature to the one with lower temperature. Naturally heat transfers from hot to cold. A small amount of the energy that was directed towards the earth from the sun is absorbed by the atmosphere, a larger amount (about 30%) is reflected back to space by clouds and the Earth's surface, and the remaining is absorbed at the planet surface and then partially released as heat. Energy is transferred between the Earth's surface and the atmosphere in a variety of ways, including **radiation**, **conduction**, and **convection**. The figure below uses a camp stove to summarize the various mechanisms of heat transfer. If you were standing next to the camp stove, you would be warmed by the **radiation** emitted by the gas flame. A portion of the radiant energy generated by the gas flame is absorbed by the frying pan and the pot of water.

By the process of **conduction**, this energy is transferred through the pot and pan. If you reached for the metal handle of the frying pan without using a potholder,

you would burn your fingers! As the temperature of the water at the bottom of the pot increases, this layer of water moves upward and is replaced by cool water descending from above. Thus **convection** currents that redistribute the newly acquired energy throughout the pot are established.

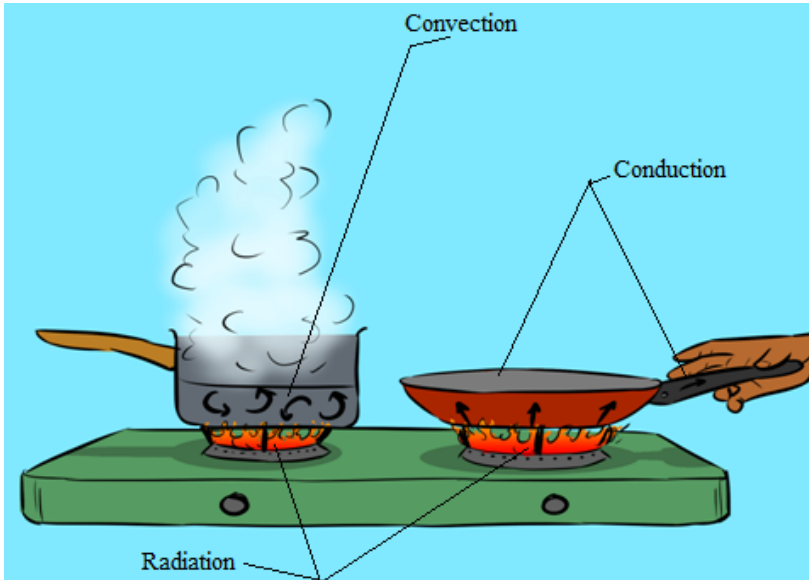

*Fig.2. 7: Camp stove to summarize the various mechanisms of heat transfer.*

As in this simple example using a camp stove, the heating of the Earth's atmosphere involves radiation, conduction, and convection, all occurring simultaneously. A basic theory of meteorology is that the Sun warms the ground and the ground warms the air. This activity focuses on **radiation**, the process by which the Sun warms the ground. Energy from the Sun is the driving force behind weather and climate.

### Quick check 2.1

What do trees, snow, cars, horses, rocks, centipedes, oceans, the atmosphere, and you have in common?

Each one is a source of radiation to some degree. Most of this radiation is invisible to humans but that does not make it any less real.

Radiation is the transfer of energy by electromagnetic waves. The transfer of energy from the Sun across nearly empty space is accomplished primarily by radiation. Radiation occurs without the involvement of a physical substance as the medium. The Sun emits many forms of **electromagnetic radiation** in varying quantities.

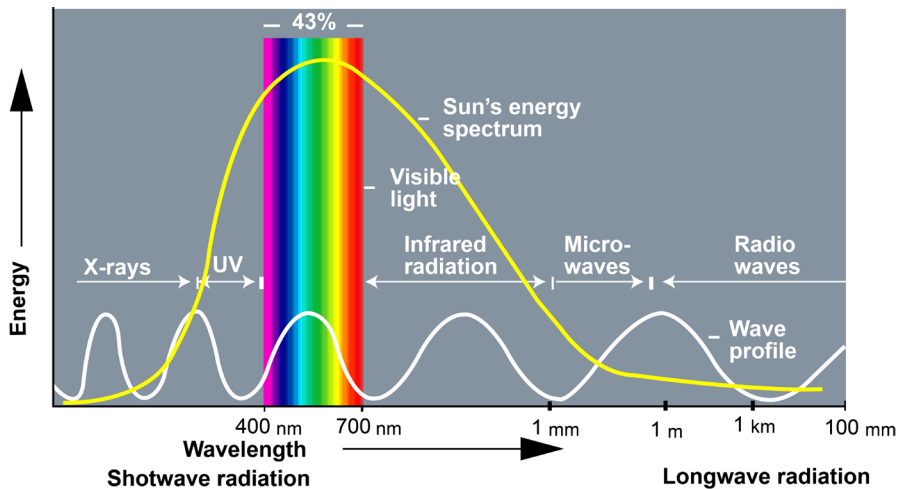

Fig.2. 8: The spectrum of electromagnetic radiations emitted by the sun

About 43% of the total radiant energy emitted from the Sun is in the visible part of the spectrum. The bulk of the remainder lies in the near-infrared (49%) and ultraviolet (7%) bands. Less than 1% of solar radiation is emitted as x-rays, gamma rays, and radio waves.

A perfect radiating body emits energy in all possible wavelengths, but the wave energies are not emitted equally in all wavelengths; a spectrum will show a distinct maximum in energy at a particular wavelength depending upon the temperature of the radiating body. As the temperature increases, the **maximum radiation** occurs at shorter wavelengths.

The hotter the radiating body, the shorter the wavelength of maximum radiation. For example, a very hot metal rod will emit visible radiation and produce a white glow. On cooling, it will emit more of its energy in longer wavelengths and will glow a reddish color. Eventually no light will be given off, but if you place your hand near the rod, the infrared radiation will be detectable as heat.

The amount of energy absorbed by an object depends upon the following:

- The object's absorptivity, which, in the visible range of wavelengths, is a function of its color
- The intensity of the radiation striking the object

Every surface on Earth absorbs and reflects energy at varying degrees, based on its color and texture. Darker-colored objects **absorb** more visible radiation, whereas lighter-colored objects **reflect** more visible radiation. These concepts are clearly discussed in unit two.

## 2.2.2 Environmental heat energy and mass transfer

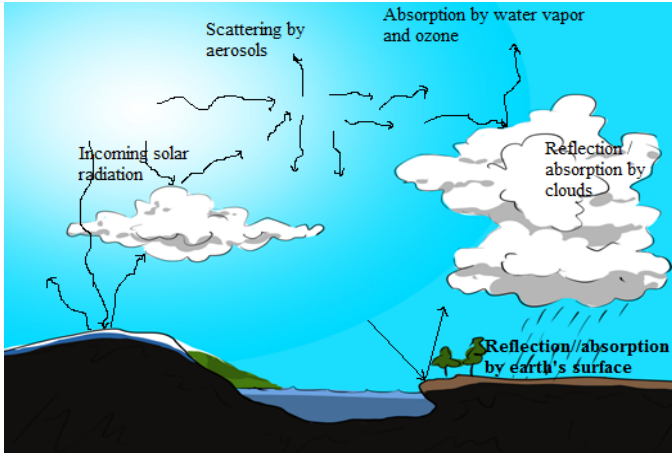

Fig.2. 9: Illustration of interactions of solar radiations with different constituents of the atmosphere.

Practically all of the energy that reaches the earth comes from the sun. Intercepted first by the atmosphere, a small part is directly absorbed, particularly by certain gases such as ozone **and water vapor**. Some energy is also reflected back to space by clouds and the earth's surface.

In the atmosphere, convection includes large- and small-scale rising and sinking of air masses.. These vertical motions effectively distribute heat and moisture throughout the atmospheric column and contribute to cloud and storm development where rising motion occurs) and dissipation where sinking motion occurs.

## 2.2.3 Water vapour in the atmosphere.

### ACTIVITY 2.5: Impact of water vapor in agricultural activities

1. Brainstorm on water vapor in the atmosphere and explain clearly how it impacts on agricultural activities?
2. Does water vapor play an important role in the atmosphere? Justify your answer with clear reasons.

When **water vapor** condenses onto a surface, a net warming occurs on that surface. The **water** molecule brings heat energy with it. In turn, the temperature of the **atmosphere** drops slightly. In the **atmosphere**, condensation produces clouds, fog and precipitation (usually only when facilitated by cloud condensation nuclei).

### The role of water vapor in the atmosphere

Water vapor plays a dominant role in the **radiative balance** and the **hydrological cycle**. It is a principal element in the thermodynamics of the atmosphere as it transports latent heat and contributes to absorption and emission in a number of bands. It also condenses into clouds that reflect and adsorb **solar radiation**, thus directly affecting the energy balance.

In the lower atmosphere, the water vapor concentrations can vary by orders of magnitude from place to place.

### **2.2.4 Variation in Atmospheric Pressure**

**Variation with height or vertical variation:** The pressure depends on the density or mass of the air. The density of air depends on its temperature, composition and force of gravity. It is observed that the density of air decreases with increase in height so the pressure also decreases with increase in height.

**Horizontal variation of pressure:** The horizontal variation of atmospheric pressure depends on temperature, extent of water vapor, latitude and land and water relationship.

Factors affecting atmospheric pressure:

1. Temperature of air
2. Altitude
3. Water vapor in air
4. Gravity of the earth.

Effect of atmospheric pressure in agricultural activities

The pressure exerted by the atmosphere of the earth's surface is called **atmospheric pressure**. Generally, in areas of higher temperature, the **atmospheric pressure** is low and in areas of low-**temperature the pressure** is high. Atmospheric pressure has no direct influence on crop growth. It is, however an important parameter in weather forecasting.

### **2.2.5 Air density and water vapour with altitude**

#### **ACTIVITY 2.6: Effect of air density in the atmosphere**

Brainstorm on air density and explain clearly its affects in the earth's atmosphere?

The **density of air** (air density) is the **mass** per unit **volume** of **earth's atmosphere**. Air density, like air pressure, decreases with increasing altitude. It also changes with variation in temperature and **humidity**. At **sea level** and at

15 °C air has a density of approximately 1.225 kg/m<sup>3</sup>.

Air density and the water vapor content of the air have an important effect upon engine performance and the takeoff characteristics of air-craft. Some of the effects these two factors have upon engine takeoff, and the methods for computing these elements from a meteorological standpoint. Pressure altitude, **density altitude**, vapor pressure, and specific humidity in the atmosphere are determined using a Density Altitude Computer.

**Pressure altitude:** Pressure altitude is defined as the altitude of a given atmospheric pressure in the standard atmosphere. The pressure altitude of a given pressure is, therefore, usually a fictitious altitude, since it is equal to true altitude only rarely, when atmospheric conditions between sea level and the altimeter in the aircraft correspond to those of the standard atmosphere. Aircraft altimeters are constructed for the pressure-height relationship that exists in the standard atmosphere.

### 2.2.6 Checking my progress

1. Why does atmospheric pressure change with altitude?
2. The graph below gives an indication of how pressure varies non-linearly with altitude. Use the graph to answer the following questions:

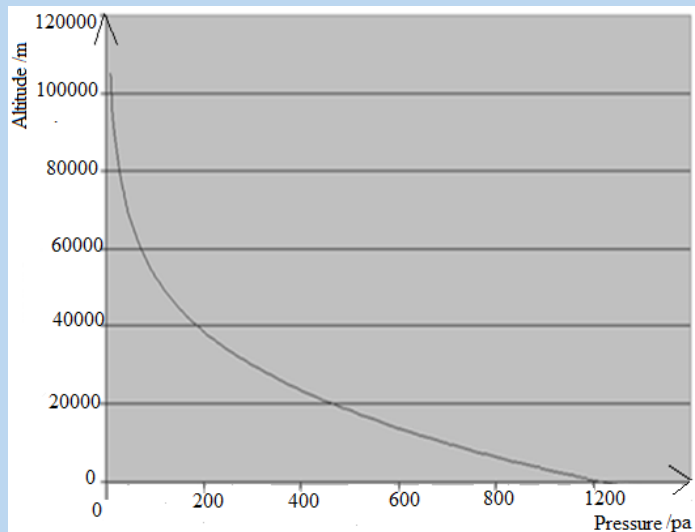

Fig.2. 10: A graph of altitude vs pressure

- a. Explain what happens to pressure if the altitude reduces?
- b. Estimate the atmospheric pressure when someone is at an altitude of 40 km above sea level.

## 2.3 PHYSICAL PROPERTIES OF SOIL

### ACTIVITY 2.7: How the surface of earth reflects and absorbs heat

Perform the activity to investigate how different surfaces of the earth reflect and absorb heat and apply this knowledge to real-world situations. It justifies that the physical characteristics of the Earth's surface affect the way that surface absorbs and releases heat from the Sun.

#### Materials needed in demonstration

- |                                 |   |
|---------------------------------|---|
| - Three pie pans or dishes      | - Dark potting soil                           |
| - Light-colored sand or perlite | - Water                                       |
| - Three thermometers            | - Reflector lamp with incandescent light bulb |
| - Watch with a second hand      | - Graph paper                                 |
| - Colored pencils               | - Heating and Cooling Data Table              |

#### Procedures

- Brainstorm on the already known concepts about how the color and type of material affects how hot it gets in the sunshine. Try to think about these questions. When it is a hot day, what color shirt would you wear to keep cool and why? During the summer, what would it feel like to walk on gravel with no shoes?
  - In performing activity, explore how different types of surfaces found at the earth's surface (such as sand, soil, and water) heat up when the sun's energy reaches them, and how they cool down when out of the sunshine.
  - Note that this experiment uses materials to model sunshine and earth materials. Observe the materials and realize how each material relates to the earth system. (The lamp represents the sun in this model. The sand represents beaches, sand dunes, and rocks. The potting soil represents large areas of soil outdoors. And the water represents lakes, rivers, and the ocean.)
- Fill the pie pans to the same level, one with dark soil, one with light sand, and one with water.
- Place the pie pans on a table or desk and position the lamp about 30.48 cm above them. (Do not turn on the lamp yet.)

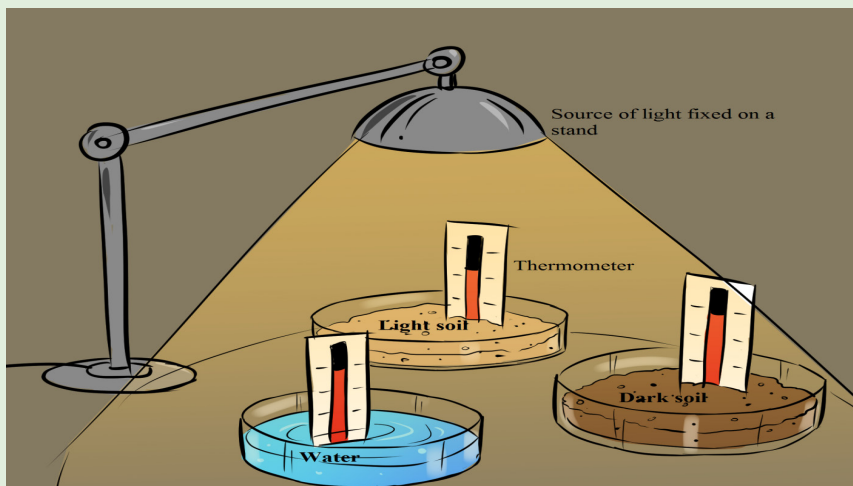

Fig.2. 11: Arrangement of pie pans to investigate the absorption of solar radiation.

### Checking skills Questions

1. Which material absorbed more heat in the first ten minutes?
2. Which material lost the most heat in the last ten minutes?
3. Imagine that it is summer and that the Sun is shining on the ocean and on a stretch of land.
  - a. Which one will heat up more during the day?
  - b. Which one will cool more slowly at night? Explain.
4. Imagine three cities in the desert, all at about the same altitude and latitude. Which city would likely have the highest average summer air temperature and why?
  - One city (A) is surrounded by a dark-colored rocky surface.
  - Another city (B) is surrounded by a light-colored sandy surface.
  - The third city (C) is built on the edge of a large man-made desert lake.
5. The Earth's surface tends to lose heat in winter. Which of the above cities would have the warmest average winter temperature? Why?
6. Since the Sun is approximately 93 million miles from the Earth and space has no temperature, how do we get heat from the Sun?

Physical properties of a soil that affect a plant's ability to grow include: **Soil texture**, which affects the soil's ability to hold onto nutrients (cation exchange capacity) and water. Texture refers to the relative distribution of the different sized particles in the soil. It is a **stable property** of soils and, hence, is used in soil classification and description. **Soil structure**, which affects aeration, water-holding capacity, drainage, and penetration by roots and seedlings, among other

things. Soil structure refers to the arrangement of soil particles into aggregates and the distribution of pores in between. It is **not a stable property** and is greatly influenced by soil management practices.

### 2.3.1 Soil texture

#### ACTIVITY 2.8

Soil texture is determined by three proportions of the soil. Brainstorm and try to answer questions using knowledge gained.

- a. Outline three proportions of the soil?
- b. What does the underlined word mean?

**Soil texture**, or the 'feel' of a soil, is determined by the proportions of sand, silt, and clay in the soil. When they are wet, sandy soils feel gritty, silty soils feel smooth and silky, and clayey soils feel sticky and plastic, or capable of being moulded. Soils with a high proportion of sand are referred to as 'light', and those with a high proportion of clay are referred to as 'heavy'.

The names of **soil texture classes** are intended to give you an idea of their textural make-up and physical properties. The three basic groups of texture classes are sands, clays and loams. A soil in the **sand group** contains at least 70% by weight of sand. A soil in the **clay group** must contain at least 35% clay and, in most cases, not less than 40%. A loam soil is, ideally, a mixture of sand, silt and clay particles that exhibit light and heavy properties in about equal proportions, so a soil in the **loam group** will start from this point and then include greater or lesser amounts of sand, silt or clay.

### 2.3.2 Soil structure

#### ACTIVITY 2.9

- a. It is known that soil structure contains soil particles and pores and is classified under physical properties of soil. Brainstorm and write short notes on soil structure.

Use the knowledge gained in part (a) above to answer questions in part (b).

- b. (i) List the elements found in soil particles.  
  
(ii) What do the underlined words mean?  
  
(iii) Explain the role of pores in soil structure that improves capillary action in plant growth.

Structure is the arrangement of primary sand, silt and clay particles into secondary aggregates called peds or structural units which have distinct shapes and are easy to recognize. These differently shaped aggregates are called the structural type.

**There are 5 basic types of structural units:**

- **Platy:** Plate-like aggregates that form parallel to the horizons like pages in a book. This type of structure may reduce air, water and root movement.
- **Blocky:** Two types--angular blocky and sub angular blocky. These types of structures are commonly seen in the B horizon. Angular is cube-like with sharp corners while sub angular blocky has rounded corners.
- **Prismatic:** Vertical axis is longer than the horizontal axis. If the top is flat, it is referred to as prismatic. If the top is rounded, it is called columnar.
- **Granular:** Peds are round and pourous, spheroidal. This is usually the structure of A horizons.
- **Structureless:** No observable aggregation or structural units.

Good soil structure means the presence of aggregations which has positive benefits for plant growth. These benefits arise from the wider range of pore sizes which result from aggregation. The nature of the pore spaces of a soil controls to a large extent the behavior of the soil water and the soil atmosphere. It influences the **soil temperature**. All these affect root growth, as does the presence of soil pores of appropriate size to permit root elongation. Favorable soil structure is therefore crucial for successful crop development. The destruction of soil structure may result in a reduction in soil porosity and/or change to the pore size distribution.

**Soil structure** refers to the arrangement of soil particles (sand, silt and clay) and pores in the soil and to the ability of the particles to form aggregates. **Aggregates** are groups of soil particles held together by organic matter or chemical forces. **Pores** are the spaces in the soil. The pores between the aggregates are usually large (macro pores), and their large size allows good aeration, rapid infiltration of water, easy plant root penetration, and good water drainage, as well as providing good conditions for soil micro-organisms to thrive. The smaller pores within the aggregates or between soil's particles (micro pores) hold water against gravity (capillary action) but not necessarily so tightly that plant cannot extract the water.

A well-structured soil forms stable aggregates and has many pores (Fig.3.12 A). it is friable, easily worked and allows germinating seedlings to emerge and to

quickly establish a strong root system. A poorly structured soil has either few or unstable aggregates and few pore spaces (Fig.3.12 B). This type of soil can result in unproductive compacted or waterlogged soils that have poor drainage and aeration. Poorly structured soil is also more likely to slake and to become eroded.

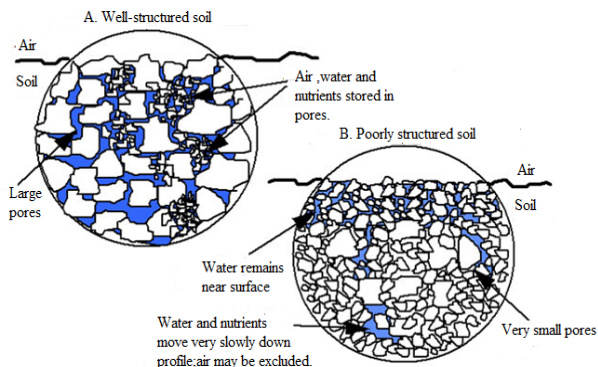

Fig.3. 12: Different soil structures: well structured and poorly structured soil.

### 2.3.3 Checking my progress:

1. Explain the physical properties of Soil and explain clearly how each impact agricultural activities?
2. (a) Explain how the weathering of rocks contributes to soil formation.  
 (b) Explain the following terms as used in the context of soil and plant growth.
  - I. Well structured soil
  - II. Poor structured soil
- (c) The following table shows the water content of three soil samples. Use the table to answer questions that follows:

Soil Sample	% Water in soil sample 1	% Water at soil sample 2
A	6	2
B	24	12
C	30	22

Analytical Questions:

- I. What is the percentage of available water in sample A?
  - II. Which sample would be the most suitable for a crop suffering a drought during the growing season?
  - III. Which sample would be the most suitable for a crop growing during a rainy season?
- (d) Describe an experiment to compare the capillarity of two contrasting soils.

## 2.4 MECHANICAL WEATHERING

### 2.4.1 Concepts of mechanical weathering

#### ACTIVITY 3.10: Exploring Mechanical Weathering

Mechanical rock weathering is an important part of the formation of both soils and new rocks, and an important part of the entire rock cycle. The activity explores what causes rocks to break down.

#### Materials:

- Coffee can with lid
- Rocks
- Dark-coloured construction paper

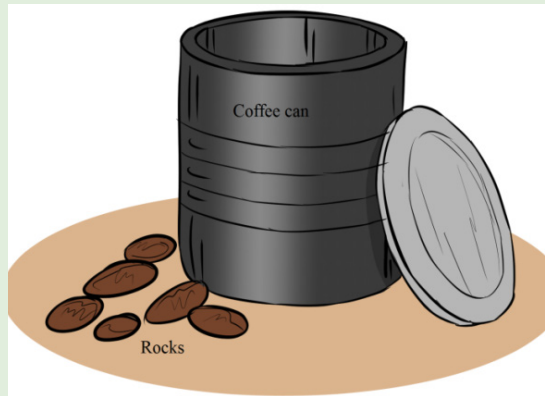

Fig.2. 13 Coffee can with lid

#### Procedures

Place a handful of rocks on a piece of dark-coloured construction paper. Observe the rocks and take notes on their appearance. Place the rocks in a coffee can. Put the lid on the can and shake the can forcefully for 2 minutes, holding the lid tightly shut. Pour the rocks onto the construction paper. Observe them and take notes on any changes in their appearance.

#### Use the skills gained above to answer the following questions:

- d. What happened to the rocks and why?
- e. What forces in nature might affect rocks in similar ways?

#### Briefly explain what causes mechanical weathering?

Earth's surface is constantly changing. Rock is integrated and decomposed, moved to lower elevations by gravity, and carried away by water, wind, or ice. When a rock undergoes mechanical weathering, it is broken into smaller

and smaller pieces of sediment and dissolved minerals; each retaining the characteristics of the original material. The result is many small pieces from a single large one.

Weathering takes place in two ways: physical weathering and chemical weathering. Physical and chemical weathering can go on at the same time. Weathering is thus the response of Earth's materials to change environment. **Weathering** is the first step in the breakdown of rock into smaller fragments. This process is critical to the formation of landscapes and many other geological processes. Our discussion will focus on mechanical weathering. **Mechanical weathering** is the physical breaking up of rocks into smaller pieces.

### 2.4.2 Causes of mechanical weathering

#### Temperature change

#### ACTIVITY 3.11: Effects of temperature on mechanical weathering

- a. Brainstorm on the effects of temperature in mechanical weathering and explain clearly its impacts on soil formation and agricultural activities?
- b. Explain how thermal expansion and contraction affect mineral composition?

As the water evaporates, the salt is left behind. Over time, these salt deposits build up, creating pressure that can cause rocks to split and weaken. **Temperature changes** also affect **mechanical weathering**. As **temperatures** heat up, the rocks themselves expand.



Fig.2. 14 Illustration of mechanical weathering

Temperature is an essential part of rock creation, modification and destruction. Heating a rock causes it to expand, and cooling causes it to contract. Repeated swelling and shrinking of minerals that have different **expansion** and **contraction** rates should exert some stress on the rock's outer shell.

### **Thermal expansion and contraction of minerals**

Thermal expansion is the tendency of matter to change in shape, area, and volume in response to a change in temperature. Thermal expansion due to the extreme range of temperatures can shatter rocks in desert environments. Temperature is a monotonic function of the average molecular kinetic energy of a substance. When a substance is heated, the kinetic energy of its molecules increases. Thus, the molecules begin vibrating more and usually maintain a greater average separation.

Materials which contract with increasing temperature are unusual; this effect is limited in size, and only occurs within limited temperature ranges. The relative expansion (also called strain) divided by the change in temperature is called the material's **coefficient of thermal expansion** and generally varies with temperature. Materials expand or contract when subjected to changes in temperature. Most materials expand when they are heated, and contract when they are cooled. When free to deform, concrete will expand or contract due to fluctuations in temperature. Concrete expands slightly as temperature rises and contracts as temperature falls. Temperature changes may be caused by environmental conditions or by cement hydration.

Thermal expansion and contraction of concrete varies primarily with aggregate type (shale, limestone, siliceous gravel and granite), cementitious material content, water cement ratio, temperature range, concrete age, and ambient relative humidity. Of these factors, aggregate type has the greatest influence on the expansion and contraction of concrete.

#### **Quick Check 2.2**

1. How does climate affect the rate of weathering?
2. What is the process that breaks down rocks?

#### **a. Effects of temperature and moisture changes on weathering**

At high elevations, cold night time temperatures during much of the year can produce relentless freeze-thaw cycles. This process explains the presence of broken boulders and stony fragments that litter mountaintops. And, the minerals in volcanic rock that formed at the highest temperatures and pressures are the most vulnerable to chemical weathering at Earth's surface.

In many locations, changes in temperature and moisture content of the environment cause significant physical weathering. When rock is warmed, it expands; when it cools, it contracts. In some regions, rocks are heated to relatively high temperatures during the day and then cooled to much lower temperatures during the night. The constant expansion and contraction of the rocks may result in pieces being broken off. Temperature also affects the land as the cool nights and hot days always cause things to expand and contract. That movement can cause rocks to crack and break apart.

The most common type of mechanical weathering is the constant **freezing**, and **thawing of water**. In liquid form, water is capable of penetrating holes, joints, and fissures within a rock. As the temperature drops below zero celcius, this water freezes. Frozen **water** expands compared to its liquid form. The result is that the holes and cracks in rocks are pushed outward. Even the strongest rocks are no match for this force.

As temperatures heat up, the rocks themselves expand. As the temperatures cool down, rocks contract slightly. The effect can be the weakening of the rock itself which induces mechanical weathering. It breaks rock into smaller pieces. These smaller pieces are just like the bigger rock, but smaller. That means the rock has changed physically without changing its composition. The smaller pieces have the same **minerals**, in just the same proportions as the original rock.

### b. Ice wedging

There are many ways that **rocks** can be broken apart into smaller pieces. **Ice wedging** is the main form of mechanical weathering in any climate that regularly cycles above and below the **freezing** point (**Fig.2.15**). Ice wedging works quickly, breaking apart rocks in areas with temperatures that cycle above and below **freezing** in the day and night.

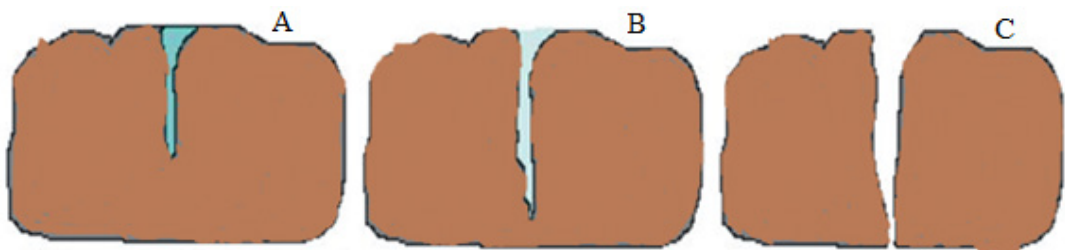

*Fig.2. 15 Ice wedging.*

### Explanation of figure 3.15:

(A) water seeps into cracks and fractures in rock, (B) when the water freezes, it expands about 9% in volume, which wedges apart the rock, (C) with repeated freeze cycles, rock breaks into pieces.

Ice wedging breaks apart so much, rocks with large piles of broken rock are seen at the base of a hillside, as rock fragments separate and tumble down. Ice wedging is common in Earth's polar regions and mid latitudes, and also at higher elevations in the mountains. Water has the unique property of expanding about 9% when it freezes. This increase in volume occurs because, as ice form, the water molecules arrange themselves into a very open crystalline structure. As a result, when water freezes, it expands and exerts a tremendous outward force. This can be verified by completely filling a container with water and freezing it.

After many freezing cycle, the rock is broken into pieces. This process is called **frost wedging** also as known as **Freeze-thaw weathering** as shown in Fig.3.13. This occurs when water gets into the small holes and gaps in rocks. If the water in the gap freezes, it expands, splitting the existing gaps into wider cracks. When the water thaws, the wider gaps allow even more water to enter the rock and freeze. Frost wedging can repeat over months or years, turning microscopic gaps in the rock into large cracks. Ice has more volume than liquid water, so the cracks are forced wider. Then, more water accumulates in the cracks the next day, which freeze at night to widen the cracks further. When this happens repeatedly, the rock eventually breaks apart along the crevices.

**Frost heaving**, a similar process to frost wedging, occurs when a layer of ice forms under loose rock or soil during the winter, causing the ground surface to bulge upward. When it melts in the spring, the ground surface collapses.

### c. Abrasion

#### ACTIVITY 2.12: Importance of abrasion in real life situations

With the help of knowledge gained in the concepts above, explain how abrasion is formed and suggest its importance in real life situations?

The word '**abrasion**' literally means scraping of the surface of an object. This is exactly what happens with abrasion of rocks. Weathering by abrasion is responsible for the creation of some of the largest deserts in the world. The rock's surface is exposed to blown sands - high velocity winds which blow throughout the day while carrying large sand particles.

The sand blasts against the surfaces of the rocks, undercutting and deflating them. As a result, smaller rock particles are formed, which when exposed to further sand **abrasion** become sand particles themselves.

Abrasion makes rocks with sharp or jagged edges smooth and round. If you have ever collected beach glass or cobbles from a stream, you have witnessed the work of abrasion (**Fig.2.16 below**). Rocks on a beach are worn down by abrasion as passing waves cause them to strike each other.



*Fig.2. 16 Smooth round rocks*

In abrasion, one rock bumps against another rock. The following are the causes of abrasion;

- Gravity causes abrasion as a rock tumbles down a mountainside or cliff.
- Moving **water** causes abrasion as particles in the water collide and bump against one another.
- Strong winds carrying pieces of sand can sandblast surfaces.
- Ice in **glaciers** carries many bits and pieces of rock. Rocks embedded at the bottom of the glacier scrape against the rocks.

Therefore abrasion occurs when the surface of rocks is exposed to water or wind. These elements can carry tiny particles of sediment or rock that then collide against the rock's surface. When these particles rub against the rock's surface, they break off tiny pieces of the rock. Over time, abrasion can wear down and smooth extremely large sections of the rock.

#### **d. Biological activity**

Weathering is also accomplished by the activities of organisms, including plants, burrowing animals, and humans. Plant roots in search of minerals and water grow into fractures, and as the roots grow they wedge the rock apart . Burrowing animals further break down the rock by moving fresh material to the surface, where physical and chemical process can more effectively attack it. Decaying organisms also produce acids, which contribute to chemical weathering .

### 2.4.3 Factors influencing the type and rate of rock weathering

#### ACTIVITY 2.13

Brainstorm and classify clearly the factors affecting the rate of weathering?

Several factors influence the type and rate of rock weathering. By breaking a rock into smaller pieces, the amount of surface area exposed to chemical weathering is increased. The presence or absence of joints can be significant because they influence the ability of water to penetrate the rock. Other important factors include the mineral makeup of rocks and climate.

#### a. Climate

The amount of water in the air and the temperature of an area are both part of an area's climate. Moisture speeds up chemical weathering. Weathering occurs fastest in hot, wet climates. It occurs very slowly in hot and dry climates. Without temperature changes, ice wedging cannot occur. In very cold, dry areas, there is little weathering.

#### b. Surface area

Most weathering occurs on exposed surfaces of rocks and minerals. The more surface area a rock has, the more quickly it will weather. When a block is cut into smaller pieces, it has more surface area. So, therefore, the smaller pieces of a rock will weather faster than a large block of rock

#### c. Rock composition

Headstones of granite, which is composed of silicate minerals, are relatively resistant to chemical weathering. The minerals that crystallize first form under much higher temperatures than those which crystallize last. Consequently, the early formed minerals are not as stable at Earth's surface, where the temperatures are different from the environment in which they formed. Olivine crystallizes first and is therefore the least resistant to chemical weathering, whereas quartz, which crystallizes last, is the most resistant.

#### d. Pollution speeds up weathering

Factories and cars release carbon dioxide and other gases into the air. These gases dissolve in the rainwater, causing **acid rain** to form. Acid rain contains nitric and sulfuric acid, causing rocks and minerals to dissolve faster.

## e. Soil erosion and soil deposition

### ACTIVITY 2.14: Soil erosion

Look at the figure below that represents soil erosion. Carefully study the figure and answer the following questions:



*Fig.2. 17 The erosive force of wind on an open field.*

- What do you think caused water to get contaminated as shown in fig below
- How often have you seen water looking like that in your area. What was the cause?
- What scientific phenomena that explains the washing away of the top soil.
- how does the phenomena explained in c) above affect agriculture?
- Suggest possible measures that can be taken to reduce or stop the phenomenon explained in c) above

Soil covers most land surfaces. Along with air and water, it is one of our most indispensable resources. Soil is a combination of mineral and organic matter. Soil erosion is a naturally occurring process that affects all landforms. In agriculture, soil erosion refers to the wearing away of a field's topsoil by the natural physical forces of water and wind or through forces associated with farming activities.

**Erosion** is incorporation and transportation of material by a mobile agent, usually water, wind, or ice. **Erosion** whether it is by water and wind, involves three distinct actions – soil detachment, movement and deposition. Topsoil, which is high in organic matter, fertility and soil life, is relocated elsewhere “on-site” where it builds up over time or is carried “off-site” where it fills in drainage channels. Soil erosion reduces cropland productivity and contributes to the pollution of adjacent watercourses, wetlands and lakes. **Soil erosion** can be a slow process that continues relatively unnoticed or can occur at an alarming rate, causing serious loss of topsoil.

Soil compaction, low organic matter, loss of soil structure, poor internal drainage and soil acidity problems are other serious soil degradation conditions that can accelerate the soil erosion process.

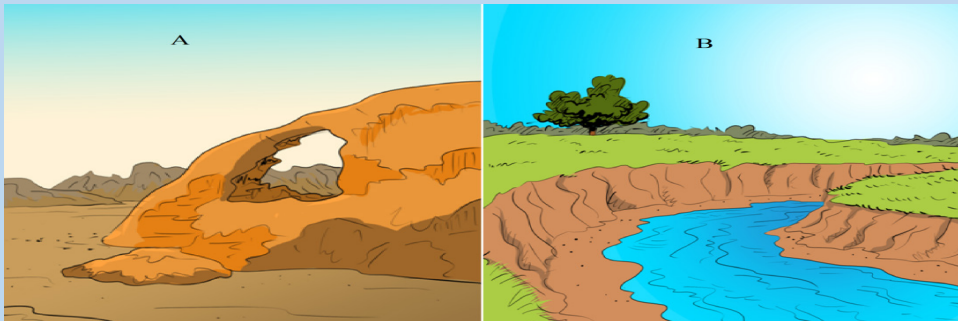

*Fig.2. 18 The erosive force of water from concentrated surface water runoff.*

Deposition is the geological process in which sediments, soil and rocks are added to a landform or land mass. Wind, ice, and water, as well as sediment flowing via gravity, transport previously eroded sediment, which, at the loss of enough kinetic energy in the fluid, is deposited, building up layers of sediment.

### **2.4.4 Checking my progress**

The pictures A and B are of two geographical features. Look and carefully study the pictures to answer questions below.



*Fig.2. 18 Illustration of geographical features*

- Interpret the images above and Use your observation to suggest names of the corresponding geographical features in the image above?
- Do you have such geographical features in your district or neighboring districts? Use your observation to explain clearly the two geographical features occurring in the image above?
- Explain the causes for each geographical feature occurring above?
- Can the geographical features identified above impact agriculture in our communities? Explain with clear facts to support your decision.
- What are moral and ethical issues associated with the geographical features given above?

## END UNIT ASSESSMENT 2

### A. Multiple choices questions

For question 1 to 5, choose the letter of the best answer

1. It is known that earth's atmosphere has a series of layers, each with its own specific characteristics and properties? The following is the appropriate layer where we live.
  - a. Thermosphere
  - b. Troposphere
  - c. Stratosphere
  - d. Mesosphere
2. Consider the following statements:
  - I. The atmosphere of Earth protects life on Earth by absorbing ultraviolet solar radiation, warming the surface through greenhouse effect and reducing temperature extremes between day and night.
  - II. X-rays and ultraviolet radiation from the Sun are absorbed in the thermosphere.
  - III. The stratosphere extends from the top of the thermosphere to about 50 km above the ground.

Of these statements:

- a. I, II, and III are correct.
  - b. I, II and III are wrong
  - c. I and II are correct but III is wrong
  - d. I and III are wrong but II is correct
3. Agrophysics is defined as
    - a. The branch of science dealing with study of matter and energy and their mutual relation.
    - b. The branch of science dealing with communication devices to measure and collect information about physical conditions in agricultural and natural environments.
    - c. The branch of natural sciences dealing with the application of physics in agriculture and environment.
    - d. None of these

### B. Structured Questions

1. Write the missing word or words on the space before each number.
  - For items (a)-(i)
  - a. \_\_\_speeds up chemical weathering.
  - b. Weathering happens \_\_\_\_\_ in hot, wet (humid) climates.
  - c. Weathering occurs very slowly in \_\_\_\_\_ and \_\_\_\_\_ climates.

- d. Without \_\_\_\_\_ changes, ice wedging cannot occur
  - e. In very \_\_\_\_\_ and \_\_\_\_\_ areas, there is little weathering.
  - f. Most weathering occurs on \_\_\_\_\_ of rocks and minerals
  - g. The \_\_\_\_\_ surface area a rock has, the quicker it will weather.
  - h. Some minerals resist weathering. \_\_\_\_\_ is a mineral that weathers slowly.
  - i. Rocks made up of minerals such as feldspar, \_\_\_\_\_, and iron, weather more quickly.
2. If the statement is true, write true. If it is false, change the underlined word or words to make the statement true.
- a. Water vapor is very important in predicting weather.
  - b. Temperature is a reason why atmosphere is more dense close to the earth's surface.
  - c. Agrophysics plays an important role in the limitation of hazards to agricultural objects and environment.
  - d. Energy is transferred between the earth surface and planet in a variety of ways.
  - e. As the temperature increases in the atmosphere, the minimum radiation occurs at short wavelengths.
3. Write a sentence describing the relationship between each pair of terms.
- I. Gravity, atmosphere
  - II. Temperature, rocks.
4. Marry wants to make agrophysics journal. She says, "My journal will be focused on advances in sensors and communication devices to measure and collect information about physical conditions in agricultural and natural environments". Evaluate Marry's statement.
5. With the help of two clear examples on each, explain clearly how temperature and water vapor impact agricultural activities using the table.

Terms	Impact of temperature and water vapor in agricultural activities.
1. Temperature	
2. Water vapor	

6. Complete the chart below. If the left column is blank, give the correct term. If the right column is blank, give an example of economic activities taking place in the corresponding layer if possible.

Term	An example of economic activities taking place in the corresponding layer if available.
1.Troposphere	
2.Stratosphere	
3. Mesosphere	
4.Thermosphere	

7. How do climate impact agricultural activities?

8. Explain briefly the role of machines in agriculture in rapid development of the country towards suitable programs of transformation and modernization of agriculture?

9. Knowing different stages of growing plants in our daily agriculture activities, explain clearly which stages mostly benefit the use of technology?

10. Cracks in rocks widen as water in them freezes and thaws. How does this affect the surface of Earth?

11. Name the four factors that can hasten or speed up the process of weathering.

12. How is weathering different from erosion?

13. How can increasing the surface area of rock hasten or speed up the process of weathering

14. Human activities are responsible for enormous amounts of mechanical weathering, by digging or blasting into rock to build homes, roads, and subways or to quarry stone. Suggest measures that can be taken to minimize mechanical weathering caused by human activities?

### C. Essay type questions

15. Design and conduct your own research into the influence of surfaces on temperature comparing earth surfaces that interest them (such as colored soils, dry and wet soils, grass, dry leaves, or different types of coverings such as plastic or aluminum foil). Compare the data with these new surfaces compared to the given surfaces (water, light soil, dark soil). Note that the data may not be comparable due to variations in experimental design, such as differences in light bulb temperature and height of the lamp.

# UNIT 3

## FOSSIL AND NON-FOSSIL FUEL AND POWER PRODUCTION

**Key unit competence:** By the end of this chapter, I should be able to evaluate fossil and non-fossil fuel for power production.

### Unit Objectives:

#### By the end of this unit I will be able to;

- explain the concept of fossil and no-fossil fuels and their use in power production properly.
- explain the differences between fossil and no-fossil fuels properly.
- explain Nuclear fuel and nuclear fission and their use in energy production and associated dangers properly.
- explain the environmental problems of fossil fuels and suggest their solution clearly.



### 3.0 INTRODUCTORY ACTIVITY

Fossil fuel is a source of conventional or non-renewable energy. There are many examples of fossil fuels which we use in our daily lives. In fact, most of the energy that we consume comes from fossil fuels. Coal, petroleum and natural gas are called fossil fuels. Millions of years ago, during the carboniferous age, due to the change in atmospheric conditions and other changes, the forests were destroyed and they were fossilized. With the action of bacteria and other microorganisms on the surface of the earth, these trees and other vegetations were decayed and disintegrated. Years after these trees were available in solid, liquid and gaseous state. The solid form is coal. It is the most widely used form of fossil fuel for domestic purposes.

#### ACTIVITY 3.1: The Atmosphere

Crossword puzzle: Fill the missing words in the crossword puzzle given below.

##### Down

1. \_\_\_\_\_ refers to the rise in the world's average temperature due to air pollution.
2. \_\_\_\_\_ are gases in the atmosphere that absorb and emit radiation, causing the greenhouse effect.
3. \_\_\_\_\_ is a mixture of smoke and fog in the atmosphere.
4. \_\_\_\_\_ is a non-renewable source of energy formed from the remains of dead plants and animals.

##### Across

5. \_\_\_\_\_ is the reduction of the amount of ozone
6. The water sources and the land are polluted by \_\_\_\_\_ when exhaust gases dissolve in the rain.

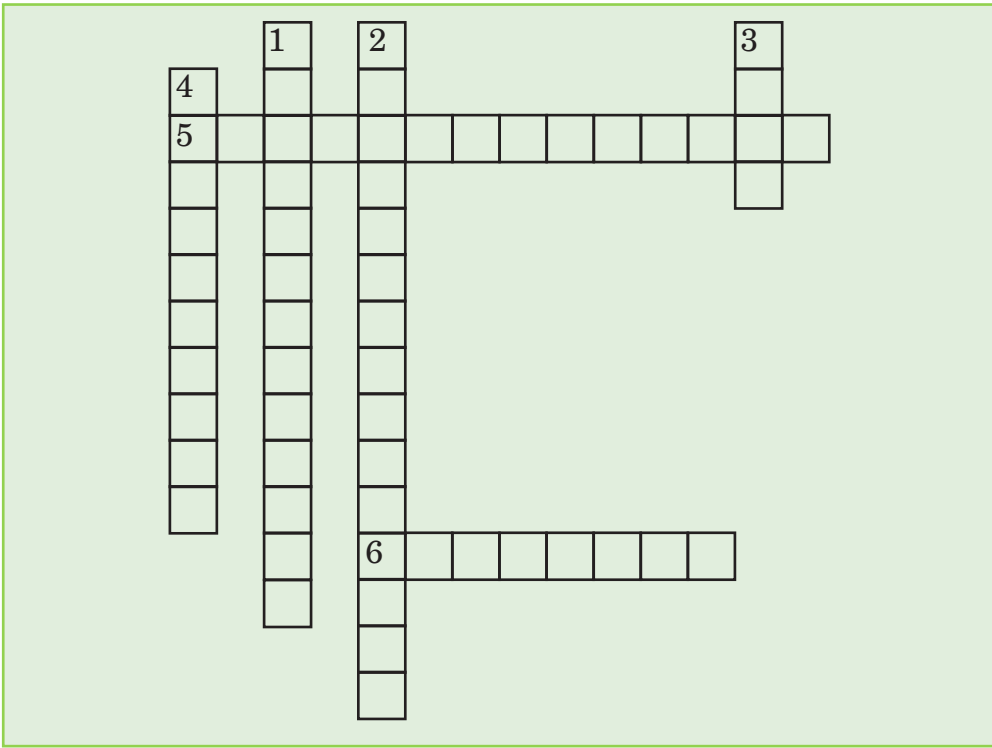

### ACTIVITY 3-2: Pollution

#### Word splash

The following are the key words we learn about air pollution.

Burning of fossil fuel

Acid rain

Rapid Population growth

Factories

Global warming

Ozone Depletion

Motor vehicles

Power plants

Use the words to complete the diagram below:

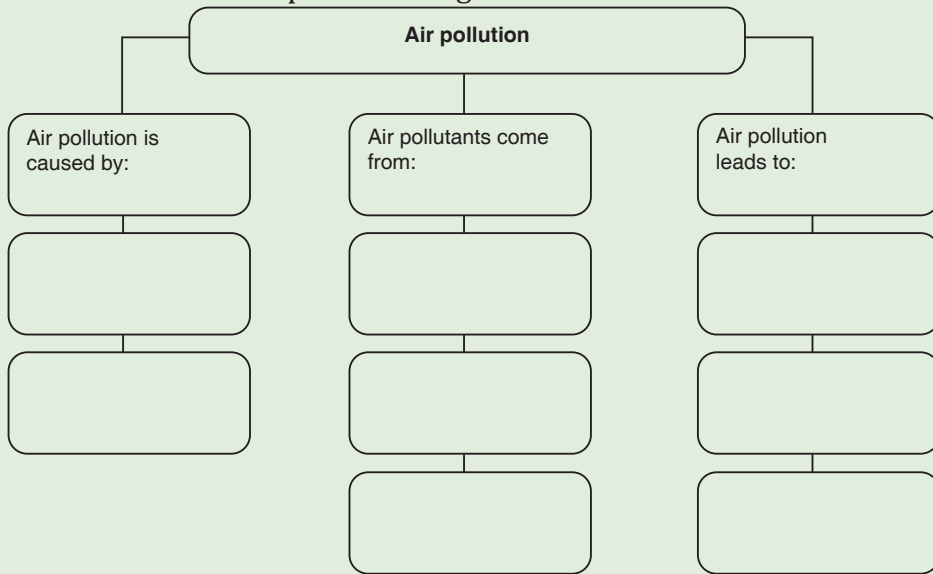

### 3.1. FOSSIL FUELS AND NON-FOSSIL FUELS

#### 3.1.1 Fossil Fuels

Fossil fuels are hydrocarbons, primarily coal, fuel oil or natural gas, formed from the remains of dead plants and animals. In common dialogue, the term 'fossil fuel' also includes hydrocarbon-containing natural resources that are not derived from animal or plant sources.

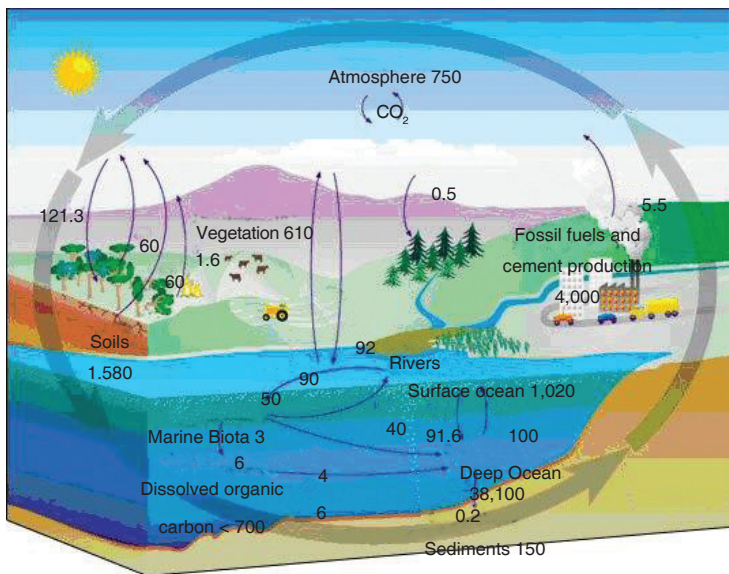

Fig. 3.1. Fossil fuels in nature

Coal, oil and natural gas are called '**fossil fuels**' because they have been formed from the fossilized remains of prehistoric plants and animals. Fossil fuels are non-renewable energy source since they take millions of years to form. They ultimately get their energy from the sun.

## Types of Fossil Fuels

### Coal

Coal is a hard, black coloured rock-like substance formed when dead plants were subjected to extreme heat and pressure for millions of years. It is made up of carbon, hydrogen, oxygen, nitrogen and varying amounts of sulphur. There are two ways to mine coal: surface mining and underground mining.

### Natural Gas

Natural gas is formed from the remains of tiny sea animals and plants that died millions of years ago. The gas then became trapped in layers of rock-like water in a wet sponge. Raw natural gas is a mixture of different gases. Its main ingredient is methane. The strange smell of natural gas (like rotten eggs) comes from a chemical added by the companies. It is called *mercaptan*. This is added to detect the gas leakage.

### Oil (Petroleum)

Oil is formed from the remains of animals and plants that died millions of years ago. The organic material was then broken down into hydrogen and carbon atoms and a sponge-like rock was formed, full of oil.

Oil cannot be used as it is when it is drawn from the ground. Oil refineries clean and separate the oil into various fuels and byproducts. The most important of these is gasoline.

Fossil fuels are used to generate electrical energy in a series of energy transformations as shown in Fig.6.2.



Fig. 3.2. Generation of electrical energy using fossil fuels

### 3.1.2 Non-fossil fuels

Non-fossil fuels are alternative sources of energy or renewable sources of energy that do not rely on burning up limited supplies of coal, oil or natural

gas. Examples of these fuels include: nuclear energy, wind or water generated energy and solar power. These tend to be renewable energy sources, or means of generating power that can be utilized indefinitely.

Non-fossil fuels are considered to be extremely important for power creation. This is because they are usually renewable energy sources that could be tapped for hundreds of years and not run out. In addition, energy production using nonfossil-based fuels usually generates much less pollution than fossil-based energy sources.

## **3.2 Storage and transportation of different types of fossil fuels**

### **3.2.1 Coal**

#### **Types of coal**

- Peat
- Lignite
- Semi bituminous
- Bituminous
- Anthracite

#### **Means of transporting coal**

- Transportation by rail
- Transportation by ropeways
- Transportation by sea or river
- Road transport
- Transport by pipeline

#### **Coal storage**

**Storage of coal is undesirable because it costs more as there is:**

- Risk of spontaneous combustion,
- Weathering,
- Possibility of loss and deterioration during storage,
- Interest on capital cost of coal lying dormant,
- Cost of protecting the stored coal from deterioration.

## **Types of coal storage**

### **1. Dead storage:**

This storage supplies the coal to places where there is a shortage of coal in plant due to failure of normal supply of coal. This is a long-term storage and comprises 10% of annual consumption, so, it requires protection against weathering and spontaneous combustion.

### **2. Living storage:**

It supplies coal to plant for day-to-day usage. The capacity of live storage is less than that of dead storage. It is usually stored in vertical cylindrical bunkers or coal basins or silos, e.g. coal is transferred to boiler grate. Bunkers are normally diamond-shaped cross-section storage areas made up of steel or reinforced concrete.

### **Purpose of dead coal storage of coal**

- To prevent shutdown of power plant in case of failure of normal supplies of coal due to coal strike, failure of the transport system, etc.
- To permit choice of purchase allowing management to take advantage of seasonal market conditions.

## **Means of coal storage**

### **1. Storage in coal heaps**

It is required to:

- Keep coal at low temperature ( $>70^{\circ}\text{C}$ ).
- Prevention of air circulation from bottom of coal piles.
- Proper drainage of rainy water to prevent weathering—drainage should not be rapid to prevent washing of coal.

Hence, ground used for stocking should be dry and levelled for proper drainage. It should have concrete floor to prevent flow of air from bottom. Coal is piled up to a height of about 10 m to 12 m in layers of 15 cm to 30 cm.

In dead storage, coal pile is sealed by asphalt, fine coal dust, bituminous or other coating materials.

### **2. Underwater storage**

Possibility of slow oxidation and spontaneous combustion can be completely eliminated by storing coal under water.



*Fig. 3.3. Coal dead storage*

### **Site selection for coal dead storage**

- The storage should be free from standing water
- If well drainage is not available, artificial drainage should be provided.
- It should be free from all foreign materials like wood, paper rags, waste oil or materials having low ignition temperature.
- Handling cost should be minimum.
- Pile should build up in successive layers and be compact.
- Pile should be dressed to prevent entry of rainy water.
- Alternative drying and wetting should be avoided.
- **Stoker** size coal should be oil treated to prevent absorption of water and oxygen.
- Side of pile should not be steep.
- Air may circulate freely through pile for proper ventilation to keep temperatures low.
- Hot surfaces or boiler blow down or hot water or steam pipe and tanks should be kept far from coal storage
- Hot bright days should be avoided.
- There should be provision for temperature measurement at different points.
- Conical piling should be avoided.
- Fire fighting equipment should be easily available.

## Coal Transfer

Equipments used in coal transfer are:

### A: Belt conveyor

It can transfer large quantities of coal over large distance economically. It has low initial cost and ensures low power consumption.

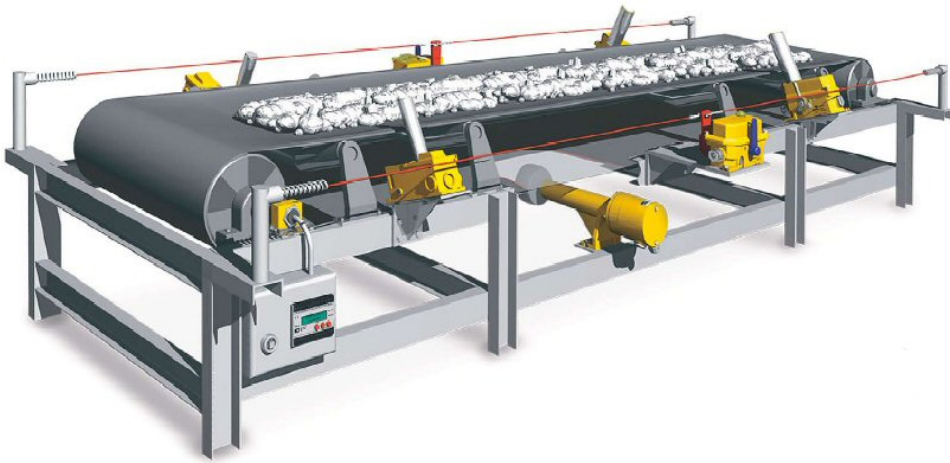

*Fig. 3.4. Belt conveyor*

#### Advantages:

- Economical, low power consumption
- Large capacity
- Rate of coal transfer rapidly change
- Low maintenance cost

#### Disadvantages

- Not suitable for shorter distance and inclination  $> 200$ .
- Not suitable for dust particles and slurry.

### B: Flight conveyor

It is used when coal is discharged at different points in bins situated below the conveyor. All parts are made of steel and iron, so it can handle hot materials. It is totally enclosed, so dust of coal can get transferred. It can transfer coal at high inclination

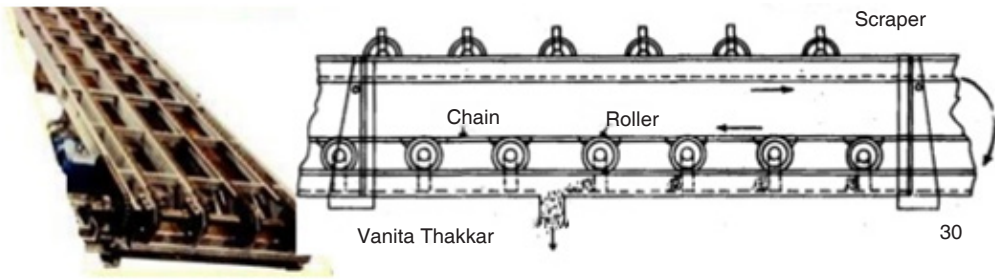

*Fig. 3.5. Flight conveyor*

### Advantages

- It requires small head room.
- Speed and material transfer rate can easily change.
- It can handle hot materials also.

### Disadvantages

- High wear and tear, so, it has short life.
- High maintenance required.
- Speed is limited up to 300 m/min due to abrasive action of material.
- High power consumption per unit of material transfer.

### C: Screw conveyor

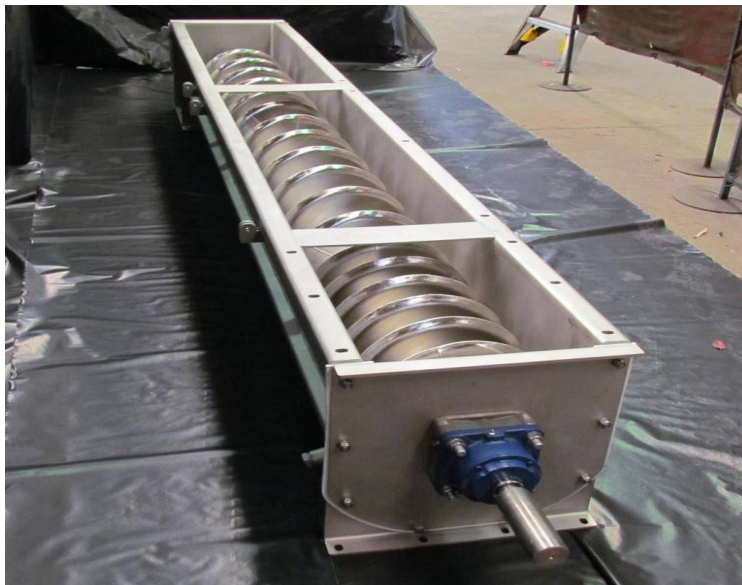

*Fig. 3.6. Screw conveyor*

- It is used for shorter distance.
- It is totally enclosed from atmosphere.

- Coal dust can also be transferred easily.
- It is generally used in metering of coal.
- Driving mechanism is attached at the end of the shaft.
- Diameter: 15 cm to 50 cm.
- Speed: 70 rpm to 120 rpm.
- Capacity: 125 tones/h (max)

### **Advantage**

- Cheap initial cost.
- Simple and compact.
- Dust tight.
- It can transfer coal at high inclination also.
- Most suitable for short distance.

### **Disadvantages**

- High power consumption.
- Length is limited up to 30 m.
- High maintenance due to high wear and tear.

### **D: Bucket elevator**

It is used for vertical lifts. Buckets are fixed on chain which moves on two wheels or sprockets. Buckets are loaded at bottom and discharged at top.

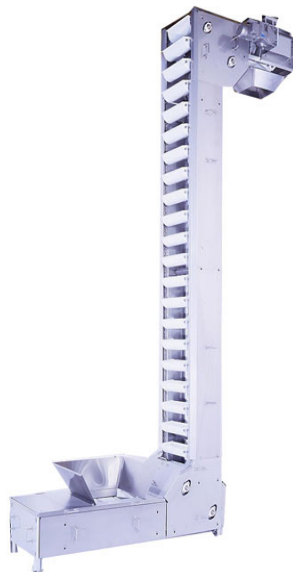

*Fig. 3.7. Bucket elevator*

### E: Grab bucket elevator

- It is used for lifting as well as transfer material.
- It can be used with crane or tower.
- Initial cost is high but operating cost is less.
- It is used when another arrangement is not possible.
- Bucket capacity: 2 to 3 m<sup>3</sup>
- Distance: 60 m
- Capacity: 100 tonnes/h.



*Fig. 3.8. Grab bucket elevator*

### 3.2.2 Transporting Natural Gas and Crude Oil

Transporting natural gas and crude oil thousands of miles through pipelines is the safest method of transportation. The transportation system for natural gas consists of a complex network of pipelines, designed to transport natural gas from its origin to the areas of high natural gas demand quickly and efficiently. In general, pipelines can be classified in three categories depending on the purpose:

#### Gathering pipelines

These are smaller interconnected pipelines forming complex networks with the purpose of bringing crude oil or natural gas from several nearby wells to a treatment plant or processing facility. In this group, pipelines are usually short — a couple of hundred metres — and with small diameters. Also sub-sea pipelines for collecting product from deep water production platforms are considered gathering systems.



*Fig. 3.9. Gathering pipelines*

### **Transportation pipelines**

These are long pipes with large diameters, moving products (oil, gas, refined products) between cities, countries and even continents. These transportation networks include several compressor stations in gas lines or pump stations for crude and multi-products pipelines.



*Fig. 3.10. Transportation pipelines*

## Distribution pipelines

These are composed of several interconnected pipelines with small diameters, used to take the products to the final consumer. Feeder lines to distribute gas to homes and business downstream, and pipelines at terminals for distributing products to tanks and storage facilities, are included in this group.



*Fig. 3.11. Distribution pipelines*

## 3.3 Advantages and disadvantages of fossil fuels

Fossil Fuel	Advantages	Disadvantages
Coal	<ol style="list-style-type: none"><li>1. Large quantities.</li><li>2. Well-distributed.</li><li>3. Converted into synthetic liquid fuels and gases.</li><li>4. Yields far more energy than renewable sources.</li><li>5. Safer than nuclear power.</li><li>6. Longer life span than oil or gas.</li><li>7. Feedstock for organic chemicals.</li></ol>	<ol style="list-style-type: none"><li>1. Causes Acid rain and global warming.</li><li>2. Not so readily transported.</li><li>3. Mining is dangerous.</li><li>4. Leaves solid residue and releases toxic gases in air, causing pollution.</li></ol>

<b>Oil</b>	<ol style="list-style-type: none"> <li>1. Easy transportation (pipelines/tankers)</li> <li>2. Use in cars, lorries, etc.</li> <li>3. Feedstock for organic chemicals</li> </ol>	<ol style="list-style-type: none"> <li>1. Acid rain + Global warming</li> <li>2. Limited lifespan</li> <li>3. Uneven distribution</li> <li>4. Risk of pollution during transportation</li> </ol>
<b>Natural Gas</b>	<ol style="list-style-type: none"> <li>1. Clean fuel</li> <li>2. Easily transported (pipelines, pressurized containers)</li> <li>3. Does not contribute to acid rain</li> <li>4. Higher quantity of energy per kg than coal or oil</li> </ol>	<ol style="list-style-type: none"> <li>1. Global warming</li> <li>2. Limited lifespan</li> <li>3. Uneven distribution</li> <li>4. Risk of explosions due to leakage</li> </ol>

### 3.4 Energy production using fossil fuels

A fossil-fuel power station is a power station which burns fossil fuels, such as coal, natural gas or petroleum to produce electricity. Central station fossil-fuel power plants are designed on a large scale for continuous operation.

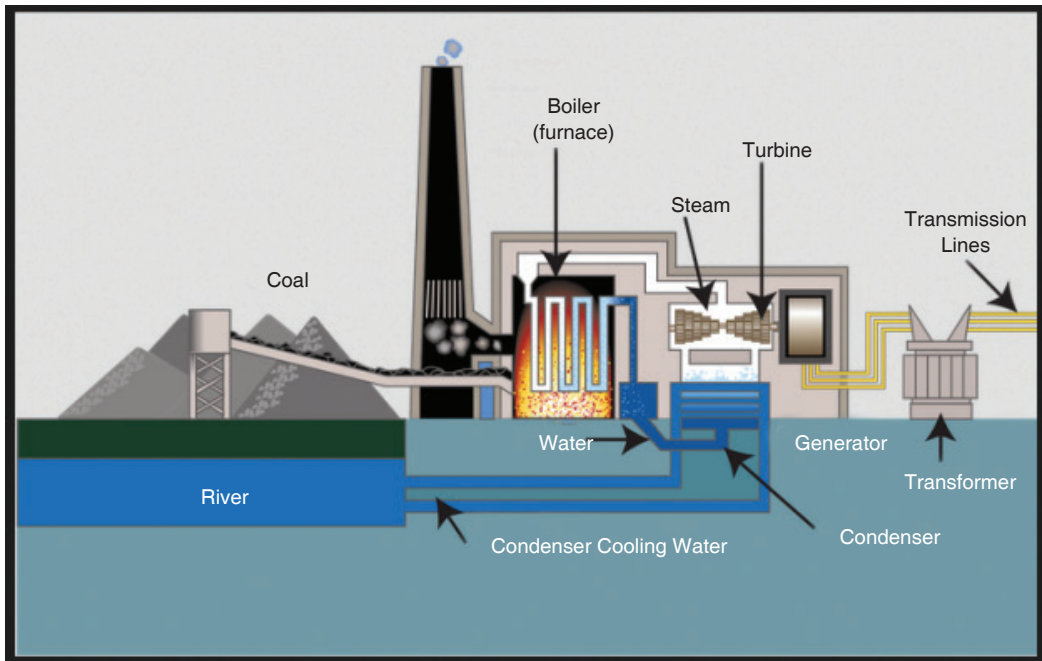

Fig. 3.12. Fossil fuel power plant

There are two main cycles in a power plant; the steam cycle and the gas turbine cycle. The steam cycle relies on the Rankine cycle in which high pressure and high temperature steam raised in a boiler is expanded through a steam turbine that drives an electric generator. The generator then transforms mechanical energy into electrical energy which is distributed for local use.

The steam gives up its heat of condensation to a heat sink, such as water from a river or a lake and the condensate can then be pumped back into the boiler to repeat the cycle. The heat taken up by the cooling water in the condenser is dissipated mostly through cooling towers into the atmosphere.

### 3.5 Nuclear fuel and nuclear fission

**Nuclear fuel** is any material that can be consumed to derive nuclear energy. The nuclear fuel can be made to undergo nuclear fission chain reactions in a nuclear reactor. The most common nuclear fuels are  $^{235}\text{U}$  (uranium 235) and  $^{239}\text{Pu}$  (plutonium 239). Not all nuclear fuels are used in fission chain reactions.

**Nuclear fission** is a process, by which a heavy nucleus splits into two or more simpler pieces. This process releases a lot of energy.

When a neutron strikes an atom of uranium, the uranium nucleus splits into two lighter atoms and releases heat simultaneously. Fission of heavy elements is an exothermic reaction which can release large amounts of energy both as electromagnetic radiation and as kinetic energy of the fragments.

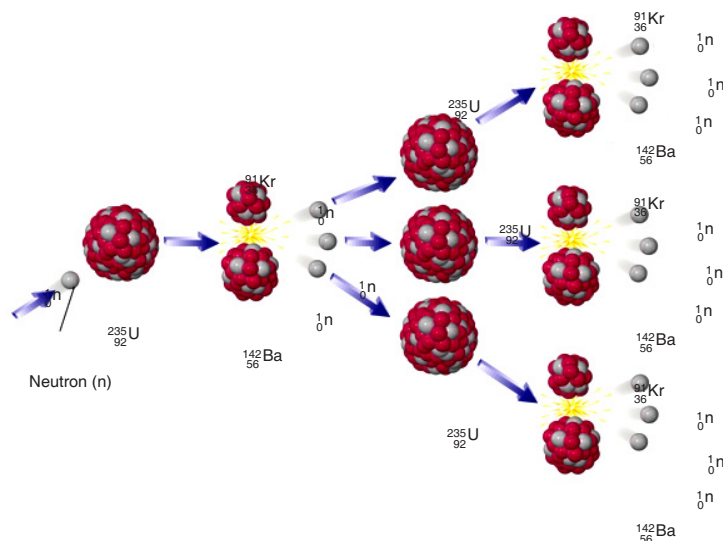
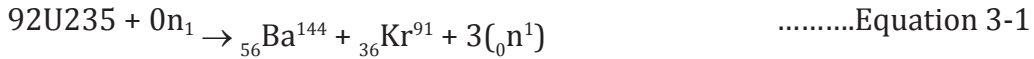

*Fig. 3.13. Fission of Uranium 235*

A chain reaction refers to a process in which neutrons released in fission

produce an additional fission in at least one further nucleus. This nucleus in turn produces neutrons, and the process continues. If the process is controlled it is used for nuclear power or if uncontrolled it is used for nuclear weapons. **Fig.3.13** illustrates a chain reaction of uranium 235.

The equation of reaction is:



### 3.6 Controlled fission (power production)

Of the three neutrons, liberated during a fission reaction, only one triggers a new reaction and the others are simply captured. The system is in equilibrium. One **fission reaction** leads to one new fission reaction, which leads to one more, and so on. This is known as controlled fission.

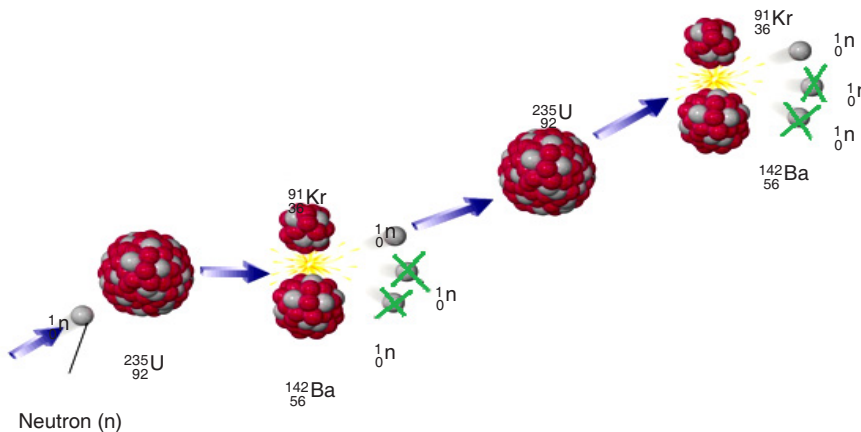

*Fig. 3.14. Controlled fission reaction*

In a nuclear power station, the uranium is first formed into pellets and then into long rods. The uranium rods are kept cool by submerging them in water. When they are removed from the water, a nuclear reaction takes place causing heat production. The amount of heat required is controlled by raising and lowering the rods. If more heat is required, the rods are raised further out of the water and if less heat is needed, they are lowered further into it.

### 3.7 Uncontrolled fission (nuclear weapons)

A fission reaction which is allowed to proceed without any moderation (by removal of neutrons) is called an uncontrolled fission reaction. Here more and more neutrons are given out and cause more fission reactions, thus, releasing large amounts of energy. An uncontrolled fission reaction is used for nuclear bombs.

Using the energy released from the nuclear fission of uranium-235, an explosive device can be made by simply positioning two masses of U-235 so that they can be forced together quickly enough to form a critical mass and result in a rapid, uncontrolled fission chain reaction.

This is not an easy task to accomplish. First, you must obtain enough uranium which is highly enriched to over 90% U-235, since natural uranium is only 0.7% U-235. This enrichment is an exceptionally difficult task, a fact that has helped control the proliferation of nuclear weapons. Once the required mass is obtained, it must be kept in two or more pieces until the moment of detonation. Then the pieces must be forced together quickly and in such a geometry that the generation time for fission is extremely short. This leads to an almost instantaneous build up of the chain reaction, creating a powerful explosion before the pieces can fly apart. Two hemispheres which are explosively forced into contact, can produce a bomb, such as the one detonated at Hiroshima in 1945.

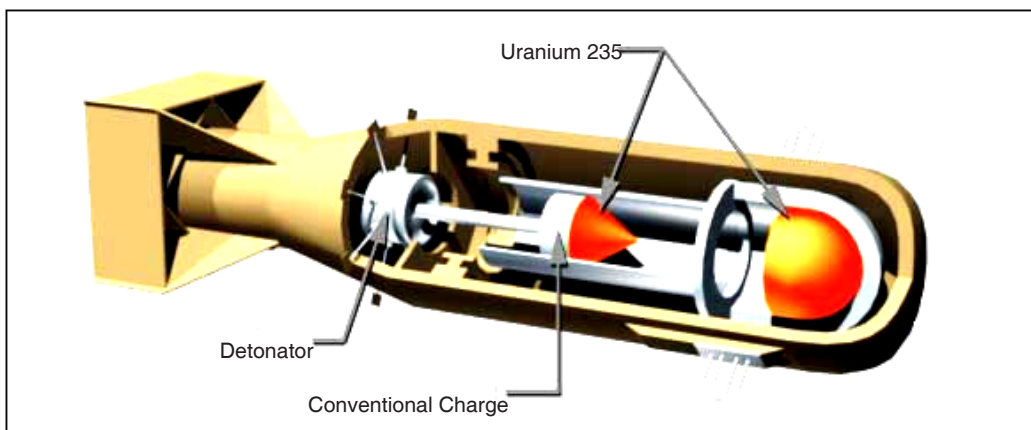

*Fig. 3.15. Nuclear atomic bomb of Uranium 235.*

### 3.8 Impacts of nuclear weapons

There are five immediate destructive effects from a nuclear explosion:

1. The initial radiation, mainly gamma rays;
2. An electromagnetic pulse, which in a high altitude explosion can knock out electrical equipment over a very large area;
3. A thermal pulse, which consists of bright light (even many miles away) and intense heat equal to that at the centre of the sun);
4. A blast wave that can flatten buildings; and
5. Radioactive fallout, mainly in dirt and debris that is sucked up into the mushroom cloud and then falls to earth.

There are three long-term effects of a nuclear explosion:

1. Delayed radioactive fallout, which gradually fall over months and even years to the ground, often in rain;
2. A change in the climate (possibly by lowering of the earth's temperature over the whole hemisphere which could ruin agricultural crops and cause widespread famine);
3. A partial destruction of the **ozone layer**, which protects the earth from the sun's ultraviolet rays. If ozone layer is depleted, unprotected Caucasians would get an incapacitating sunburn within 10 minutes, and people would suffer a type of snow blindness from the rays which, if repeated, would lead to permanent blindness. Many animals would suffer the same fate.

### 3.9 Energy transformations in a nuclear power station

In a nuclear power plant, Nuclear Steam Supply System (NSSS) consists of a nuclear reactor and all of the components necessary to produce high pressure steam, which will be used to turn the turbine for the electrical generator.

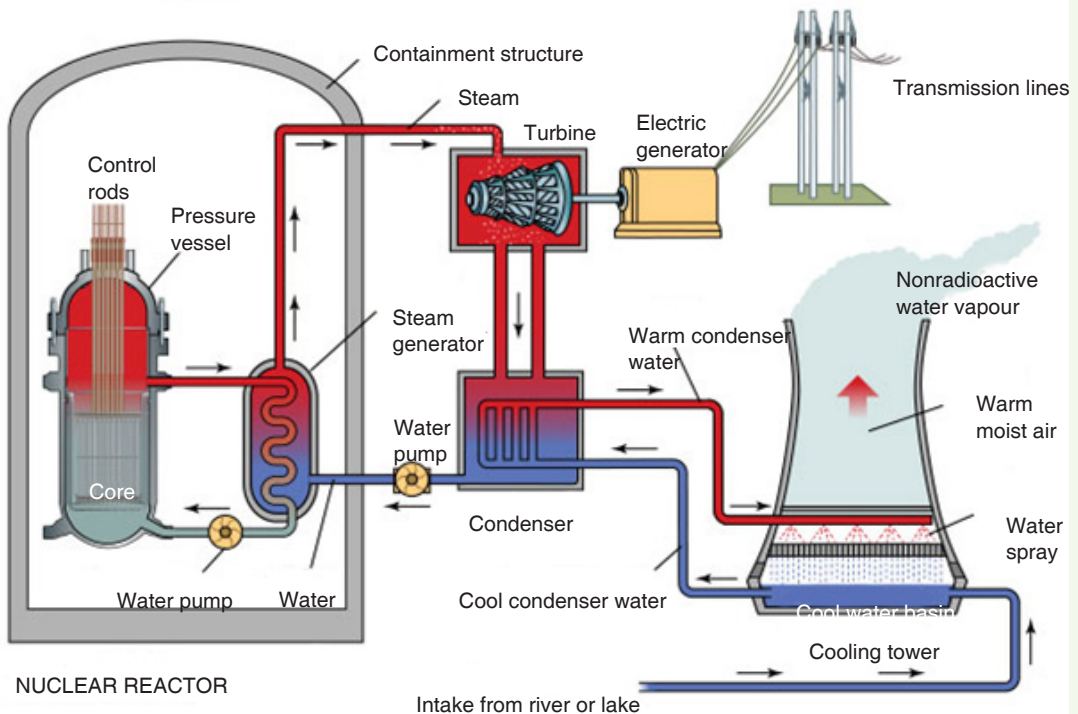

*Fig. 3.16. Nuclear power plant*

The nuclear reactor contains some radioactive isotopes like uranium which

undergo fission reaction when bombarded with some neutrons and a large amount of heat energy is evolved. This heat energy converts water into steam, which is piped to the turbine. In the turbine, the steam passes through the blades, which spins the electrical generator, resulting in a flow of electricity. After leaving the turbine, the steam is converted (condensed) back into water in the condenser. The water is then pumped back to the nuclear reactor to be reheated and converted back into steam.

### 3.10 Problems associated with the production of nuclear power

- The *problem of radioactive waste* is still unsolved. The waste from nuclear energy is extremely dangerous and it has to be carefully looked after for several thousand years (10,000 years according to United States Environmental Protection Agency standards).
- **High risks:** Despite a generally high security standard, accidents can still happen. It is technically impossible to build a plant with 100% security. A small probability of failure will always last. The consequences of an accident would be absolutely devastating both for human beings and the nature. The more nuclear power plants (and nuclear waste storage shelters) are built, the higher is the probability of a disastrous failure somewhere in the world.
- Nuclear power plants as well as nuclear waste could be preferred *targets for terrorist attacks*. Such a terrorist act would have catastrophic effects for the whole world.
- During the operation of nuclear power plants, radioactive waste is produced, which, in turn, can be used for the production of *nuclear weapons*. In addition, the same is used to design nuclear power plants can to a certain extent be used to build nuclear weapons (nuclear proliferation).
- The energy source for nuclear energy is Uranium. *Uranium is a scarce resource*; its supply is estimated to last only for the next 30 to 60 years depending on the actual demand.
- The timeframe needed for formalities, planning and building of a new nuclear power generation plant, is in the range of 20 to 30 years in the western democracies. In other words, it is an *illusion to build new nuclear power plants* in a short time.

## 3.11 Environmental problems of fossil fuels

### Climate Change/Global Warming and Greenhouse Effect

The earth's atmosphere allows a lot of sunlight to reach the earth's surface but reflects much of that light back into space. Some gases trap more sunlight, therefore, less light is reflected back into space. These gases are called **Greenhouse Gases**, because the effect is like being in a plant glasshouse, or in a car with the windows wound up. The result is a gradual increase in the earth's temperature or Global Warming. The major greenhouse gases are carbon dioxide, methane, nitrous oxide and chlorofluorocarbons (CFCs).

The main man made causes are thought to be carbon dioxide and methane from factory, power station and car emissions, the waste products of respiration, the mining of fossil fuels and the breakdown of plant matter in swamps. The long-term effects may include melting of glaciers and a rise in sea level and a global change in climate and type of vegetation.

### 'Hole' in the Ozone Layer

Ozone is a gas in the earth's upper atmosphere whose chemical formula is  $O_3$ . Ozone acts to block out much of the sun's ultraviolet radiation which causes skin cancer and contributes to the fluctuations of global climatic conditions that affect the environment. Above Antarctica, there is a thinner layer of ozone caused by the destruction of ozone gas by emissions of chlorofluorocarbons and hydrochlorofluorocarbons which are propellants in pressure-pack spray cans and refrigerants in refrigerators and air-conditioning units.

### Acid Rain

When gases, such as sulphur dioxide and nitrogen oxides react with water in the atmosphere to form sulphuric acid and nitric acid, they form an acidic 'rain' which can destroy vegetation. Some of these gases are from natural sources, such as lightning, decomposing plants and volcanoes. However, much of these gases are the result of emissions from cars, power stations, smelters and factories.

### Air Pollution

Air pollution is the release of excessive amounts of harmful gases (e.g. methane, carbon dioxide, sulphur dioxide, nitrogen oxides) as well as particles (e.g. dust of tyre, rubber, lead from car exhausts) into the atmosphere. To reduce emissions, the Australian government has legislated that all new cars should

use unleaded petrol and have catalytic converters fitted to the exhausts.

### **Water Pollution**

1. Sewage is the household waste water. Many detergents contain phosphates which act as plant fertilisers. When these phosphates and the sewerage reach rivers, they help water plants to grow in abundance, reducing the dissolved oxygen in the river water. The result is death of aquatic animals due to suffocation by the algal blooms. This harmful effect is called *eutrophication*. Eutrophication is also caused by excessive use of fertilizers in agricultural fields and subsequent surface run-off.
2. Biodegradable detergents are more environment-friendly because they are readily broken down to harmless substances by decomposing bacteria.
3. Suspended solids in water, such as silt reduce the amount of light that reaches the depths of the water in lakes and rivers. This reduces the ability of aquatic plants to photosynthesise and reduce the plant and animal life. **Turbidity** is the measure of 'cloudiness' or the depth to which light can reach in water.

### **Introduced Species**

They are species of plants or animals that have migrated or been brought to Australia. Many fit into the natural ecosystems and are kept in control by natural predators and parasites. However, some become pests as they are well-adapted to that environment, readily obtain nutrients and lack of natural predators or parasites. Examples include rabbits, foxes, carp and prickly pear cactus plant.

### **Biological Control**

It is an environment-friendly method to control these pests by the introduction of species-specific, living organisms to control their numbers. Successful examples include the myxoma virus and the calici virus for rabbits, and the cactoblastis moth feeding on the prickly pear. Unsuccessful examples include the introduction of the cane toad to reduce the numbers of natural cane beetles.

### **Biological Magnification**

It is the accumulation in body tissues of certain chemicals, such as DDT, pesticides and mercury. The higher it moves along the food chain, the greater is the accumulation, sometimes to such toxic levels, which causes birth defects and even death.

## Soil Salinity

Soil salinity has increased greatly since the widespread logging of trees by farmers. Deep tree roots normally draw water from the underground water table. However, when logging of trees occurs, the water table rises close to the surface bringing with it, salt from rocks. This makes the soil salty so that vegetation cannot grow effectively. The result is loss of vegetation and erosion.

## Population Explosion

It is the rapid increase in population in developing countries causing famine, and also in developed countries causing more demand for energy and with that, it increases pollution and destruction of the environment.

### ACTIVITY3-3: Sources of Pollution

**Aim:** the aim of this activity is to find out the causes of pollution.

**Procedure:** analyse the figure below and answer the questions that follow

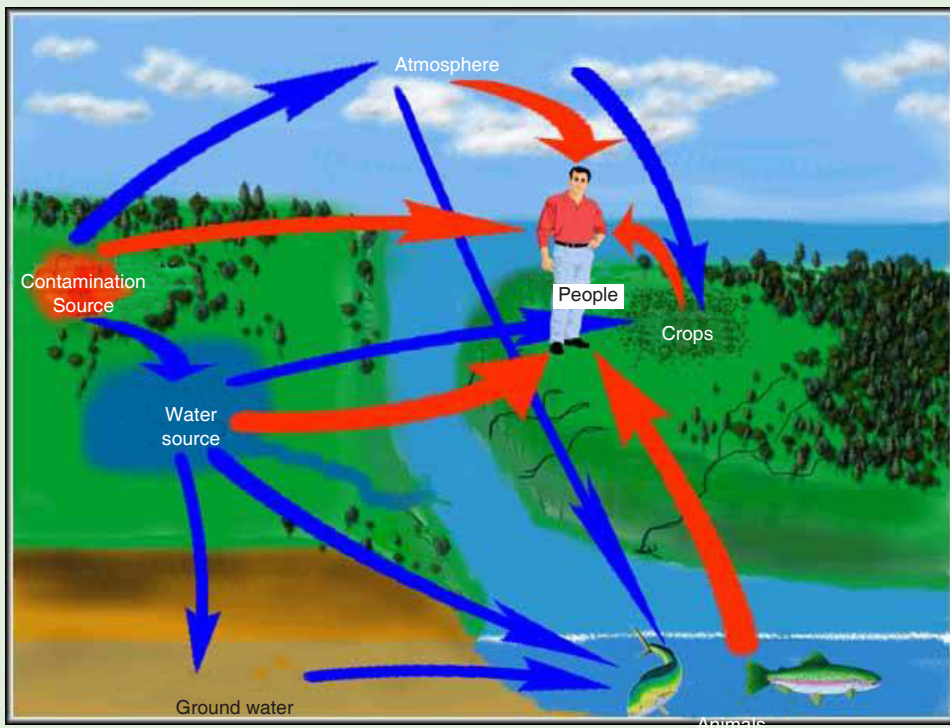

*Fig. 3.17. Effects of poorly deposited nuclear wastes.*

- a. Outline some sources of water and air pollution shown on the figure.
- b. Explain how each of the cause in (a) affect the environment.
- c. Give and explain any other sources of air and/ or water pollution you know.
- d. Explain how air and water pollutions can be reduced.

### ACTIVITY 3-4: Water Pollution

**Aim: to investigate the effect of water contamination**

Source: internet and textbooks or journals.

#### Background Information

1. Scientists have studied the influence of chlorine on organic materials in water supplies. Some of the chlorine reacts with this organic material to form chloroform and other chlorine-containing chemicals. Research has shown that some chlorine-containing chemicals can increase the risk of cancer.
2. Working with your group, find out more about the benefits and costs of using chlorine in the water supply. Have each member of your group research information on one of the following:
  - a. The risk to health of not treating water supplies with chlorine
  - b. The risk to health of using chlorine in water treatment
  - c. Alternatives to using chlorine for water treatment
  - d. Scientific research underway on chlorine use
  - e. What (if anything) is used to treat your local water supply

#### Support Your Opinion

3. When you have finished your research, share your information with your group. Design a presentation to summarize your group's findings. Be prepared to share your group's findings with the rest of the class.
4. Do you think that the amount of chlorine in our water should be increased at certain times of the year? Give reasons to support your opinion

## 3.12 Safety issues and risks associated with nuclear power

### 3.12.1 Nuclear Meltdown

A nuclear meltdown is an informal term for a severe nuclear reactor accident that results in core damage from overheating.



*Fig. 3.18. Reactor meltdowns at Fukushima Daiichi.*

A nuclear meltdown occurs when a nuclear power plant system or component fails so the reactor core becomes overheated and melts. Usually, this occurs due to the lack of coolant that decreases the temperature of the reactor. The commonly used coolant is water but sometimes a liquid metal, which is circulated past the reactor core to absorb the heat, is also used. In another case, a sudden power surge that exceeds the coolant's cooling capabilities causes an extreme increase in temperature which leads to a meltdown. A meltdown releases the core's highly radioactive and toxic elements into the atmosphere and environment.

**The causes of a meltdown occur due to:**

#### **A: A loss of pressure control**

The loss of pressure control of the confined coolant may be caused by the failure of the pump or having resistance or blockage within the pipes. This causes the coolant to cease flow or insufficient flow rate to the reactor; thus, the heat transfer efficiency decreases.

## **B: A loss of coolant**

A physical loss of coolant, due to leakage or insufficient provision, causes a deficit of coolant to decrease the heat of the reactor. A physical loss of coolant can be caused by leakages. In some cases, the loss of pressure control and the loss of coolant are similar because of the systematic failure of the coolant system.

## **C: An uncontrolled power excursion**

A sudden power surge in the reactor is a sudden increase in reactor reactivity. It is caused by an uncontrolled power excursion due to the failure of the moderator or the control that slows down the neutron during chain reaction. A sudden power surge will create a high and abrupt increase of the reactor's temperature, and will continue to increase due to system failure. Hence, the uncontrollable increase of the reactor's temperature will ultimately lead to a meltdown.

### **3.12.2 Nuclear (Radioactive) Wastes**

Nuclear wastes are radioactive materials that are produced after the nuclear reaction. Nuclear reactors produce high-level radioactive (having high levels of radioactivity per mass or volume) and low-level (having low levels of radioactivity) wastes. The wastes must be isolated from human contact for a very long time in order to prevent radiation.



*Fig. 3.19. High level waste being stored in underground repository.*

The 'high-level wastes' will be converted to a rock-like form and placed in a natural habitat of rocks, deep underground. The 'low-level wastes', on the other hand, will be buried in shallow depths (typically 20 feet) in soil.

A number of incidents have occurred when radioactive material was disposed improperly, where the shielding during transport was defective, or when the waste was simply abandoned or even stolen from a waste store.

The principal risks associated with nuclear power arise from health effects of radiation, which can be caused due to contact with nuclear wastes. This radiation consists of sub-atomic particles travelling at or near the velocity of light (186,000 miles per second). They can penetrate deep inside the human body where they can damage biological cells and thereby initiate a cancer. If they strike sex cells, they can cause genetic diseases in progeny.

### END UNIT ASSESSMENT 3

1. Why should solar energy be harnessed to take care of our electric power needs?
2. How do we confirm that the 'greenhouse effect' is real?
3. How does acid rain destroy forests and fish?
4. Is it possible to eliminate the air pollution from coal burning?
5. Radioactivity can harm us by radiating from sources outside our bodies, by being taken in with food or water or by being inhaled into our lungs. But we consider only one of these pathways. Why is it so?
6. Cancers from radiation may take up to 50 years to develop, and genetic effects may not show up for a hundred years or more. How, then, can we say that there will be essentially no health effects from the Three Mile Island accident?
7. Air pollution may kill people now, but radiation induces genetic effects that will damage future generations. How can we justify our enjoying the benefits of nuclear energy while future generations bear the suffering from it?
8. Can the genetic effects of low-level radiation destroy the human race?
9. Isn't the artificial radioactivity created by the nuclear industry, more dangerous than the natural radiation which has always been present?

10. Can radiation exposure to parents cause children to be born with two heads or other such deformities?
11. Can a reactor explode like a nuclear bomb?
12. If reactors are so safe, why don't home owners' insurance policies cover reactor accidents? Does this mean that insurance companies have no confidence in them?
13. How is radioactive waste disposed off?
14. How long will the radioactive waste be hazardous?
15. How will we get rid of reactors when their useful life is over?

Fossil fuels are hydrocarbons, primarily coal, fuel oil or natural gas, formed from the remains of dead plants and animals.

### **Types of Fossil Fuels**

- Coal
- Natural Gas
- Oil (Petroleum)

### **Types of coal storage**

- Dead storage
- Living storage

### **Means of coal storage**

- Storage in coal heaps
- Underwater storage

### **Energy production using fossil fuels**

A fossil-fuel power station is a power station which burns fossil fuel, such as coal, natural gas or petroleum to produce electricity.

### **Nuclear fuel and nuclear fission**

Nuclear fuel is any material that can be consumed to derive nuclear energy.

### **Controlled fission (power production)**

When a fission reaction leads to a new fission reaction, which leads to another one and so on, it is called controlled fission. The amount of heat required is controlled by raising and lowering the rods in the reactor.

## **Uncontrolled fission (nuclear weapons)**

A fission reaction whereby the reaction is allowed to proceed without any moderation (by removal of neutrons) is called an uncontrolled fission reaction. An uncontrolled fission reaction is used for nuclear bombs.

## **Problems associated with the production of nuclear power**

- problem of radioactive waste.
- high risks.
- targets for terrorist attacks.
- nuclear weapons.
- uranium is a scarce resource.
- illusion to build new nuclear power plants.

## **Environmental problems of fossil fuels**

### **Climate Change / Global Warming and Greenhouse Effect**

The earth's atmosphere allows a lot of sunlight to reach the earth's surface, but reflects much of that light back into space.

The result is a gradual increase in the earth's temperature or Global Warming.

### **'Hole' in the Ozone Layer**

Ozone acts to block out much of the sun's ultraviolet radiation which causes skin cancer and contributes to the fluctuations of global climatic conditions that affect the environment.

### **Acid Rain**

When gases, such as sulphur dioxide and nitrogen oxides react with water in the atmosphere to form sulphuric acid and nitric acid, they form an acidic 'rain' which can destroy vegetation.

### **Air Pollution**

Air pollution is the release into the atmosphere of excessive amounts of harmful gases as well as particles.

Other environmental problems of fossil fuels include:

- Biological Control
- Biological Magnification
- Introduced Species
- Soil Salinity
- Population Explosion

# UNIT 4

## ATOMIC NUCLEI AND RADIOACTIVE DECAY

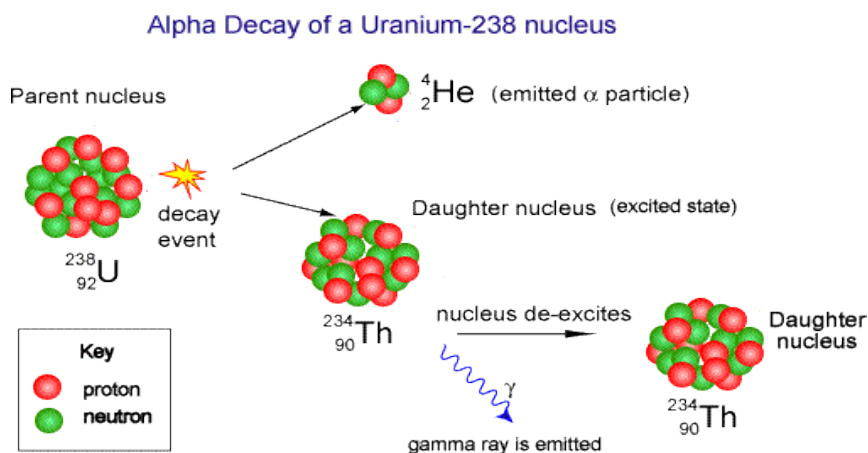

Fig.4. 1: Sign of radiation precaution.

**Key unit competence:** Analyse atomic nuclei and radioactivity decay

### My goals

- Define atomic mass and atomic number
- Identify the constituents of a nucleus
- Explain Einstein's mass-energy relation.
- Define nuclear fusion and fission.
- Analyze determinations of a mass of nuclei by using Bainbridge mass spectrometer.
- Derive the relationship between decay constant and half-life.
- Determine the stability of a nuclei.
- Describe properties of different radiations.
- Describe creation of artificial isotopes.
- Identify the application of radioactivity in life.
- Plot a graph of binding energy against nucleon and explain its features.
- Calculate the decay rate of unstable isotopes.
- Appreciate the safety precautions to be taken when handling radioactive materials.
- Appreciate that the nucleus of an atom and quantum system has discrete energy levels.

## INTRODUCTORY ACTIVITY



In different places like industries, hospitals, and other sensitive places, there are different posts that caution someone about dangerous substances one may encounter if care is not taken. Among the reasons why these places bear such instruction is because of chemicals and radiations that are used in such places which may be harmful if not handled with care.

1. Discuss some of the safety signs you have ever seen in any hospitals or industry if you have ever visited one.
2. Why do you think there is a need to put those signs in such places?
3. It is believed that there are some of diseases that are treated using radioactive substances. Can you state some of the radiations used to treat some diseases.
4. There are natural and man-made radioactive substances. All of these are used for different purposes. What are some of the negative effects of these radiations to (i) man, (ii) environment?
5. Some countries like Iran are affected by these radiations. Imagine you were a resident of that country, what would you do to protect yourself from such effects of radioactive substances.

## 4.1 ATOMIC NUCLEI-NUCLIDE

### 4.1.1 Standard representation of the atomic nucleus

#### ACTIVITY 4.1: Investigating the stable and unstable nucleus



Fig.4. 2 The standard representation of an atom nucleus

Observe the Fig.4.1 above of an atom and answer to the questions that follow:

1. What do numbers A and Z stand for?
2. Describe the relation between the two numbers and their meanings.
3. When do we say that an atom is stable or unstable?
4. Explain clearly the meaning of isotopes. Give an example of isotopes you know.

A nucleus is composed of two types of particles: **protons** and **neutrons**. The only exception is the ordinary hydrogen nucleus, which is a single proton. We describe the atomic nucleus by the number of protons and neutrons it contains, using the following quantities:

- a. The **atomic number** or the number of protons  $Z$  in the nucleus (sometimes called the charge number).
- b. The **neutron number** or the number of neutrons  $N$  in the nucleus.
- c. The **mass number** or the number of nucleons in the nucleus,

$$A = Z + N. \quad (4.01)$$

In representing nuclei, it is convenient to use the symbol  ${}^A_Z X$  to show how many protons and neutrons are present in the nucleus.  $X$  represents the chemical symbol of the element. For example,  ${}^{56}_{26}Fe$  nucleus has mass number 56 and atomic number 26. It therefore, contains 26 protons and 30 neutrons.

When no confusion is likely to arise, we omit the subscript  $Z$  because the chemical symbol can always be used to determine  $Z$ . Therefore,  ${}^{56}Fe$  is the same as  ${}^{56}_{26}Fe$  and can also be expressed as “iron-56.” Each type of atom that contains a unique combination of protons and neutrons is called **nuclide**.

### 4.1.2 Classification

Depending on the combinations of protons and neutrons in the nucleus, nuclides can be classified in the following 3 categories:

- a. Isotopes:** These are nuclei of a particular element that contain the same number of protons but different numbers of neutrons. Most elements have a few stable isotopes and several unstable, radioactive isotopes.

#### Example of isotopes:

- Oxygen has three stable isotopes that can be found in nature:  $^{16}_8\text{O}$ ,  $^{17}_8\text{O}$  and  $^{18}_8\text{O}$ . Hydrogen has two stable isotopes  $^1\text{H}$ ,  $^2\text{H}$  and a single radioactive isotope  $^3\text{H}$ .
- Carbon has two stable isotopes  $^{12}_6\text{C}$  and  $^{13}_6\text{C}$ .
- Chlorine has two stable isotopes  $^{35}_{17}\text{Cl}$  and  $^{37}_{17}\text{Cl}$ .

Therefore, the chemical properties of different isotopes of an element are identical but they will often have great differences in nuclear stability. For stable isotopes of light elements, the number of protons will be almost equal to the number of neutrons. Physical properties of different isotopes of the same element are different and therefore they cannot be separated by chemical methods i.e. only physics methods such as the centrifugation method can be used to separate different isotopes of an element.

- b. Isobars:** these are nuclei which have the same mass number but different number of protons  $Z$  or neutrons  $N$ .

**Example of isobars:**  $^{14}_7\text{N}$  and  $^{14}_6\text{N}$  which all have 14 as a mass number

- c. Isotones:** these are nuclei in which the number of neutrons is the same but the mass number  $A$  and the atomic number  $Z$  differ

**Example of isotones:**  $^{16}_8\text{O}$ ,  $^{15}_7\text{N}$  and  $^{14}_6\text{N}$  which all have 8 neutrons.

### 4.1.3 Units and dimensions in nuclear physics

The standard SI units used to measure length, mass, energy etc. are too large to use conveniently on an atomic scale. Instead appropriate units are chosen.

- **The length:** The unit of length in nuclear physics is the femtometer.

$$1 \text{ fm} = 10^{-15} \text{ m}$$

This unit is called Fermi in the honor of the Italian Americano physicists who did a lot of pioneering work in nuclear physics.

- **The mass:** The unit used to measure the mass of an atom is called the **atomic mass unit**, abbreviated “**amu or u**” and is defined as a  $\frac{1}{12}$  the mass of an atom of carbon-12. Since mass in grams of one carbon-12 atom is its atomic mass (12) divided by Avogadro’s number gives.

$$1 u = \frac{1}{6.02 \times 10^{23}} g = 1.666 \times 10^{-24} g$$

- Nuclear masses can be specified in unified atomic mass units (u).

On this scale:

- A neutral  $^{12}_6C$  atom is given the exact value 12.000000 u.
- A neutron then has a measured mass of 1.008665 u,
- A proton 1.007276 u,
- A neutral **hydrogen**  $^1_1H$  atom (proton plus electron) 1.007825 u

**Energy:** the SI unit used for energy that is Joule is too large. In nuclear physics the appropriate unit used for energy is an electronvolt (eV). An electron volt (eV) is defined as the energy transferred to a free electron when it is accelerated through a potential difference of one volt. This means that

$$1 eV = 1.6022 \times 10^{-19} C \times 1V = 1.6022 \times 10^{-19} J$$

It is also a common practice in nuclear physics to quote the rest mass energy calculated using ,

$$E = mc^2 \tag{4.02}$$

Since the mass of a proton is  $m_p = 1.67262 \times 10^{-27} kg = 1.007276 u$ , then 1 u is equal to

This is equivalent to energy in MeV of

$$1.000 u = \frac{(1.66054 \times 10^{-27} kg)(2.9979 \times 10^8 m / s^2)^2}{1.6022 \times 10^{-19} J / eV}$$

Thus,  $1u = 1.6605 \times 10^{-27} kg = 931.5 MeV / c^2$

- **The time:** the time involved in nuclear phenomena is of the order of 10-20s to million or billion years.
- **Nuclear radius:** various types of scattering experiments suggest that nuclei are roughly spherical and appear to have the same density. The data are summarized in the expression called Fermi model.

$$r = r_0 A^{\frac{1}{3}} \tag{4.03}$$

Where  $r_0 = 12 \text{ fm} = 1.2 \times 10^{-15} \text{ m}$  and A is the mass number of the nucleus

The assumption of a constant density leads to the estimate of the mass density which is obtained by considering.

$$\rho = \frac{m}{v} = \frac{Am_p}{\frac{4\pi}{3}r^3} = \frac{Am_p}{\frac{4\pi}{3}r_0^3 A} = \frac{m_p}{\frac{4\pi}{3}r_0^3} = \frac{1.6 \times 10^{-27} \text{ kg}}{\frac{4\pi}{3}(1.2 \times 10^{-15})^3} = 2.2 \times 10^{17} \text{ kg.m}^{-3}$$

This high density can explain why ordinary particles cannot go through the nucleus as highlighted by Rutherford experiments. The same density was only observed in neutron stars. The nuclear mass can be determined using a mass spectrometer.

#### 4.1.4 Working principle a mass spectrometer

The figure below highlights the working principle of a typical mass spectrometer used to separate charges of different masses. It can be used to differentiate isotopes of a certain element.

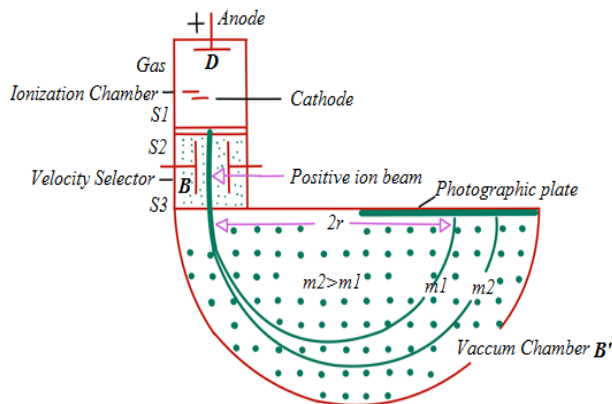

Fig.4. 3: Bainbridge mass spectrometer

Ions are formed in ionization chamber and accelerated towards the cathode. The beam passes through the cathode and is focused by the collimating slits S1 and S2. The beam is then passed through a velocity selector in which electric and magnetic fields are applied perpendicular to each other. The ion moves in straight line path for which both the forces acting on it are equal

$$qE = qvB \quad (4.04)$$

The velocity of ion which passes un-deflected through the velocity selector is then given by

$$v = \frac{E}{B} \quad (4.05)$$

The ions then reach the vacuum chamber where they are affected by the magnetic field ( $B'$ ) alone and then move in circular paths; the lighter ions having the larger path radius. If the mass of an ion is  $m$ , its charge  $q$  and its velocity  $v$  then

$$qvB' = \frac{mv^2}{R} \quad (4.06)$$

$$R = \frac{mv}{qB'} \quad (4.07)$$

The radius of the path in the deflection chamber is directly proportional to the mass of the ion. The detection is done by photographic plate when the ions fall on it. The fig. 4.5 shows the recorded mass spectrum for a gas containing three isotopes. Note the wider line for the mass  $m_1$ , showing its relatively greater abundance.

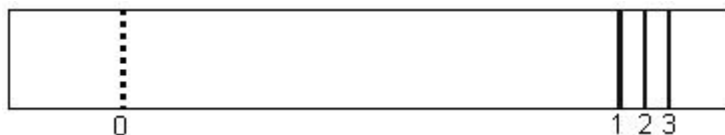

Fig.4. 4: A recorded mass spectrum of a gas containing 3 isotopes

### 4.1.5 Checking my progress

1. Write down:
  - a. word which describes the relations between the following elements  $^{12}_6C$  and  $^{14}_6C$
  - b. The nuclide symbol for an atom of chlorine ( $Cl$ ) which contains 17 protons and 18 neutrons.
2. Here is a list of particles studied in high school physics: electron, neutron, and proton. From the list, choose one particle which.
  - a. Has a positive charge
  - b. Is found in the nucleus of an atom
  - c. Is uncharged
3. How many electrons and protons are there in the following element  $^{143}_{56}X$ ? What does the symbol  $X$  means for you?
4. The number of neutrons in a nucleus of gold whose symbol  $^{197}_{79}Au$  is:
 

a. 79	c. 197	b. 118	d. 276
-------	--------	--------	--------
5. Calculate the number of neutrons in the following atoms
 

a. $^{27}_{13}Al$	b. $^{31}_{15}P$	c. $^{262}_{107}Al$	d. $^{190}_{76}P$
-------------------	------------------	---------------------	-------------------

- How many neutrons are in an atom of strontium- 90?
- Use the information given in the table below to answer the questions below concerning the elements Q, R, S, T and X.

Element	Atomic number	Mass number	Electron structure
Q	3	7	2,1
R	12	24	2,8,2
S	18	40	2,8,8
T	8	18	2,6
X	19	39	2,8,8,1

Table 4. 1 Some elements of a periodic table

## 4.2 MASS DEFECT AND BINDING ENERGY

### 4.2.1 Mass defect

#### ACTIVITY 5.2: Select the words in the following puzzle

Observe the puzzle below:

- Discover 8 different words related to particle Physics hidden in the puzzle below, and write them in your notebook.
- Use them to formulate a meaningful sentence

A	N	I	S	A	K	I	L	O	G	R	A	M
X	T	R	U	N	Q	V	U	L	Z	I	J	W
E	C	W	F	I	F	A	D	S	E	M	A	C
J	L	T	O	R	A	N	E	E	Q	A	S	A
K	E	E	R	U	R	Y	E	A	W	S	D	L
E	A	Q	C	D	J	A	E	F	T	S	U	Q
R	S	H	E	T	H	W	C	G	U	O	W	O
W	I	T	M	A	R	I	T	W	O	T	Q	Y
Q	F	B	G	E	F	O	A	E	H	W	T	E
B	I	D	O	N	G	L	N	T	M	I	U	N
A	W	U	D	E	B	O	N	V	L	H	F	E
I	Y	O	P	O	W	I	S	I	O	E	A	R
N	U	C	L	E	U	S	B	I	W	L	U	G
L	O	P	O	T	Z	A	W	Q	Y	B	T	Y
G	S	D	R	W	T	B	E	L	I	D	O	N
D	A	M	W	S	E	I	N	S	T	E	I	N

Table 4. 2 Cross word puzzle

- Complete the sentences below using the words you discovered in the puzzle
  - An .....is the SI unit of energy.

- b. On the atomic scale, the .....is not the SI unit of mass.
  - c. The .....of nucleons is greater than the mass of a nucleus.
  - d. The atom releases .....when its nucleus is formed from its constituent particles
  - e. The binding energy per nucleon gives an indication of the ..... of the nucleus.
  - f. The surprising suggestion that energy and mass are equivalent was made by .....in 1905.
4. Discuss and explain the meaning of the following expression as used in physics
- a. Mass defect
  - b. Biding energy
  - c. Electronvolt
  - d. Stable nuclides

The nucleus is composed of protons that are positively charged and neutrons that are neutral. The question is what is holding these particles together in this tiny space?

Experiences have demonstrated that the mass of a nucleus as a whole is always less than the sum of the individual masses of protons and neutrons composing that nucleus.

The difference between the two measurements is called mass defect  $\Delta m$ . For a nucleus  ${}^A_Z X$  the mass defect is given by:

$$\Delta m = Z \times m_p + (A - Z) \times m_n - M_N \quad (4.08)$$

### EXAMPLE 4.1

Compare the mass of a  ${}^4_2\text{He}$  atom to the total mass of its constituent particles.

#### Answer

The  ${}^4_2\text{He}$  nucleus contains 2 protons and 2 neutrons. Periodic tables normally give the masses of neutral atoms—that is, nucleus plus its  $Z$  electrons. We must therefore be sure to balance out the electrons when we compare masses. Thus we use the mass  ${}^1_1\text{H}$  of rather than that of a proton alone. We look up the mass of the atom in periodic table (it includes the mass of 2 electrons), as well as the mass for the 2 neutrons and 2 hydrogen atoms (= 2 protons + 2 electrons).

The mass of two neutrons and two H atoms (2 protons including the 2 electrons) is

$$2m_n = 2(1.008665 \text{ u}) = 2.017330 \text{ u}$$

$$2m_H = 2(1.007825 \text{ u}) = 2.015650 \text{ u}$$

$$\text{Thus } 2m_n + 2m_H = 2.017330 \text{ u} + 2.015650 \text{ u} = 4.032980 \text{ u}$$

Therefore the mass of  ${}^4_2\text{He}$  is measured to be less than the masses of its constituents by an amount

$$\Delta m = m_n + m_p - m_{2H} = 4.032980 \text{ u} - 4.002603 \text{ u} = 0.030377 \text{ u}$$

### 4.2.2 Einstein mass-energy relation

In 1905, while developing his special theory of relativity, Einstein made the surprising suggestion that energy and mass are equivalent. He predicted that if the energy of a body changes by an amount of energy  $E$ , its mass changes by an amount  $m$  given by the equation

$$E = mc^2 \quad (4.09)$$

Where  $c$  is the speed of light and  $m$  mass of a body

Everyday examples of energy gain are much too small to produce detectable changes of mass.

### 4.2.3 Binding energy

The mass of a nucleus is less than the combined mass of its protons and neutrons (nucleons). The missing mass is called the mass defect. This observed mass defect represents a certain amount of energy in the nucleus known as the binding energy  $E_b$ , and calculated using the Einstein formula as:

$$\Delta E = \Delta m c^2 \quad (4.10)$$

where  $c$  is the speed of light and  $\Delta m$  the mass defect.

The binding energy for a nucleus containing  $Z$  protons and  $N$  neutrons is defined as

$$\Delta E = \left( Zm_H + Nm_n - \frac{A}{Z} m \right) c^2 \quad (4.11)$$

where  ${}^A_z m$  is the mass of the neutral atom containing the nucleus, the quantity in the parentheses is the mass defect,  $\Delta m = Zm_H + Nm_n - \frac{A}{z} m$  ;  $c^2 = 931.5 \text{ MeV} / u$

The binding energy is the energy released when a nucleus is formed from its constituent particles or the energy required to break up (to split) the nucleus into protons and neutrons. Protons and electrons are held together in the nucleus of an atom by the strong nuclear force. So if we imagine splitting a nucleus up into its separate protons and neutrons, it would require energy, because we would need to overcome the strong nuclear force.

#### 4.2.4 Binding energy per nucleon and stability

Instead of looking at the total binding energy of a nucleus, it is often more useful to consider the binding energy per nucleon. This is the total binding energy divided by the total number of nucleons.

$$E_b = \frac{\Delta E}{A} = \frac{\Delta mc^2}{A} \quad (4.12)$$

#### EXAMPLE 4.2

Computer the binding energy per nucleon for  $\alpha$  particle?

**Answer:**

Alpha particles are helium nuclei  ${}^4_2\text{He}$  and the mass of helium nuclide

$$M_N = 4.00153 \text{ uma}$$

$$\Delta m = 2m_p + 2m_n - M_N$$

$$= (2 \times 1.00725) + (2 \times 1.00866) - 4.00153 = 0.03029 \text{ u}$$

The binding energy per nucleon is defined as the total binding energy of the nucleus divide by the mass number of the nuclide

$$\frac{E_b}{A} = \frac{28.3}{4} = 7.07 \text{ MeV}$$

$$E_b = 0.03029 \text{ u} \times c^2 = 28.3 \text{ Mev And } \frac{E_b}{A} = \frac{28.3 \text{ Mev}}{4} = 7.0725 \text{ Mev}$$

Since  $1 \text{ amu} = 931.494 \text{ MeV} / C^2$

A plot of binding energy per nucleon  $E_b/A$  as a function of mass number  $A$  for various stable nuclei is shown on Fig. 5.6.

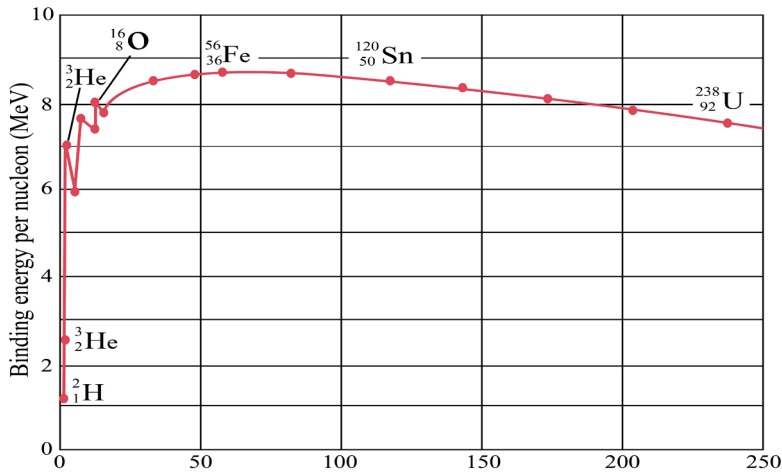

Fig.4. 5: The graph of binding energy per nucleon of the known elements (Giancoli D. C., 2005)

The nuclear binding energy per nucleon for light element increases with the mass number until a certain maximum is reached at around  $A = 56$  and then after it almost saturate. The fact that there is a peak in the binding energy per nucleon curve means that either the breaking of heavier nucleus (fission) or the combination of lighter nuclei (fusion) will yield the product nuclei with greater binding energy per nucleon and therefore more stable.

As an example if a nucleus like is  $^{238}_{92}\text{U}$  split into two fragments of nearly equal masses, the two fragments will have higher binding energy per nucleon than the original. The excess energy is released as useful energy and this process called fission is the basis of electricity production in a nucleus plant.

If two light elements combine their nuclei in one nucleus, the formed nucleus will have a greater binding energy per nucleon than the originals.



This process is called nuclear fusion and can only take place at a very high temperature. It is the source of energy in the sun and other stars. The fusion is more energetic than the fission.

The binding energy per nucleon therefore gives an indication of the stability of the nucleus. A high binding energy per nucleon indicates a high degree of stability – it would require a lot of energy to take these nucleons apart.

### 4.2.5 Checking my Progress

- What is mass defect?
  - Why does a mass defect occur?
  - What is binding energy?
- When 1.00 kg of water absorbs  $4.2 \times 10^3 J$  of energy to produce a temperature rise of 1 K, what will be the increase in mass of the water?
- Consider an example of  ${}^4_2\text{He}$  which has an atomic mass of 4.0026 u, this includes the mass of its two electrons. Its constituents comprise two neutrons each of mass 1.0087u and protons each having a mass of 1.0078 u. Find the total mass of the particles and compute its binding energy.
- Calculate the binding energy of  ${}^{16}_8\text{O}$  and its binding energy per nucleon.

## 4.3 RADIOACTIVITY AND NUCLEAR STABILITY

### ACTIVITY 4.3: Investigating radioactivity

During the World War II, its final stage was marked by the atomic bombing on Nagasaki and Hiroshima towns in Japan (Fig.5.6). Observe the image and read the text provided below before answering the following questions.



Fig.4. 6: The atomic bomb in Nagasaki (Japan in 1945)

In August 1945, after four years of world war, United States B-29 bomber, dropped the atomic bomb over the cities of Hiroshima on August 6th 1945. 70,000 people died in 9 seconds, and the city of Hiroshima was leveled. 3 days after a second bomb was dropped in Nagasaki, Japan with the same devastating results. The bombing killed over 129,000 people.

The bomb released a cataclysmic load of energy. The ones who were close enough to see the blast lost their eyes. It was the last thing they ever saw. The bright light of what blinded them. The black of their eyes, the retina, melted away. The radiation received by the body is equivalent to today's thousands of x-rays. The human body can't absorb unlimited radiation. It falls apart because the

cells are dying of radiation poisoning, if the radiation is intense enough, it looks like a urn. Layers of the skin begin to fall off. The body vital functioning began to slow down until it stops.

1. Describe and discuss the phenomena happening on two images.
2. From the text, show that the atomic bomb of Hiroshima was very harmful to human body.
3. What are the types of radiations should be there?
4. Stable isotopes do not emit radiations. What is the name of materials which emit radiations? Describe them.
5. What are the possible main radioisotopes used to produce energy in figure above?
6. Which processes are used to generate such heavy energy? Describe any one of your choice

Radioactivity is one of the dynamic properties of nuclei, in this process the system makes a transition from a high energy state to a low energy by emitting  $\alpha$  and  $\beta$ -particles or  $\gamma$ -rays. This process happens naturally and is not affected by any external agent such as pressure, temperature or electric and magnetic fields. The  $\alpha$ -particles are Helium nuclei and can be stopped by a piece of paper while  $\beta$ -particles are either electron or positron. There are high energetic particles and can pass through one cm thick aluminum sheet.  $\gamma$ -rays are electromagnetic radiations and can be stopped by several inches of lead.

### **4.3.1 Radioactive decay of a single parent**

Nucleus decay is a random process and the rate of disintegration is proportional to the number of available radioactive nuclides. Let us analyses the simple case where the first daughter nuclide is stable. Suppose that at time  $t$ , there are  $N$  radioactive nuclide and  $dN$  is the number of nuclide disintegrating within a time  $dt$ . As the rate of disintegration is proportional to the number of nuclides present in the radioactive substance, we get

$$\frac{dN}{dt} = -\lambda N \quad (4.14)$$

where  $\lambda$ , the proportionality constant, is called the radioactive constant.

This constant depends on the nature of the radioactive substance. The negative sign shows that an increase in disintegration rate will decrease the number of radioactive nuclides which are present. From this we can establish the formula of radioactive decay:

$$N = N_0 e^{-\lambda t} \quad (4.15)$$

where it assumed that the initial number of radioactive nuclide is equal to  $N_0$ .

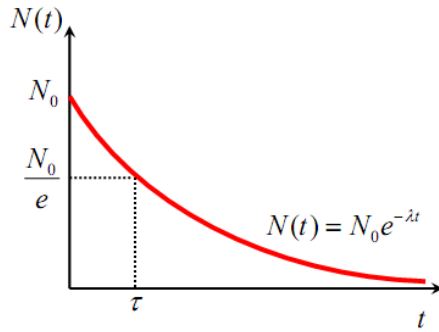

Fig.4. 7: Illustration of the radioactive decay law

If we consider the activity  $A$  of a radioactive sample which is the number of decay events in a unit time we obtain a similar expression for the radioactive decay law but expressed in terms of activity of the radioactive substance:

$$A = A_0 e^{-\lambda t}, \quad (4.16)$$

where  $A_0$  is the initial activity of the radioactive source. Another parameter useful in characterizing nuclear decay is the half-life  $T_{1/2}$ .

The half-life of a radioactive substance is the time interval during which half of a given number of radioactive nuclei decay. Therefore the half time period is

$$T_{1/2} = \frac{\ln 2}{\lambda} \quad (4.17)$$

Finally, one shows that the mean-life of a nuclide or the average life period of a nuclide is related to the radioactive constant by

$$\tau = \frac{1}{\lambda} \quad (4.18)$$

In general, after  $n$  half-lives, the number of un-decayed radioactive nuclei remaining is  $N_0 \left(\frac{1}{2}\right)^n$ .

A frequently used unit of activity is the Curie (Ci), defined as  $Ci = 3.7 \times 10^{10} \text{ decay} / s$ . This value was originally selected because it is the approximate activity of 1 g of radium. The SI unit of activity was named after Henry Becquerel (Becquerel: Bq)  $1Bq = 1 \text{ decay} / s$

Therefore,  $1Ci = 3.7 \times 10^{10} \text{ decay} / s$  the curie is a rather large unit, and the more frequently used activity units are the mill curie and the micro curie.

### EXAMPLE 4.3

The isotope  ${}^6_{14}\text{C}$  has a half-life of 5730 yr. If a sample contains  $1.00 \times 10^{22}$  carbon -14 nuclei, what is the activity of the sample?

#### Answer

The half life time in second  $T_{1/2} = 5730 \times 3600 \times 24 \times 365^{\frac{1}{4}} = 57330 \times 3.156 \times 10^7 \text{ s}$

The decay constant  $\lambda = \frac{\ln 2}{T_{1/2}} = 3.83 \times 10^{-12} \text{ s}^{-1}$

The activity or rate decay  $A = \frac{\Delta N}{\Delta t} = \lambda N = (3.83 \times 10^{-12} \text{ s}^{-1})(100 \times 10^{22}) = 3.83 \times 10^{10} \text{ Bq}$

### 4.3.2 Characteristics of radioactive substances

Radioactive substances (nuclides) present one or more of the following features

- The atom of radioactive elements are continually decaying into simpler atoms as a result of emitting radiation
- The radiations from radioactive elements produce bright flashes of light when they strike certain compounds. The compound fluoresce. For example, rays from radium cause zinc sulphide to give off light in the dark. For this reason, a mixture of radium and zinc sulphide is used to make luminous paints.
- They cause ionization of air molecules. The radiations from radioactive substances knock out electrons from molecules of air. This leaves the gas molecules with a positive charge.
- Radiations from radioactive substances can penetrate the heavy black wrapping around a photographic film. When the film is developed, it appears black where the radiations struck the film.
- Radiations from radioactive substances can destroy the germinating power of plants seeds, kill bacteria or burn or kill animals and plants. Radiations can also kill cancers.

#### A. Properties of emitted radiations

Some of their properties are summarized and shown in the table below:

Radiation	Nature	Relative charge	Relative effect of electric and magnetic field	Penetration	Distance travelled through the air	Effect on nucleus
Alpha particle	2 protons and 2 neutrons as.	2	Small deflection	Stopped by a few sheets of paper	A few cm	A decreases by 4 and Z by 2
Beta particle	Electrons	-1	Large deflection	Stopped by a few mm of plastic	A few m	
Gamma rays	Electro-magnetic radiation	0	No deflection	Stopped by several cm of lead	A few km	No change to mass or atomic number but the nucleus does lose energy.

Table 4.3 Properties of different types of radiations

### a. Alpha decay ( ${}^4_2\text{He}$ )

If one element changes into another by alpha decay, the process is called transmutation. For alpha emission to occur, the mass of the parent must be greater than the combined mass of the daughter and the alpha particle.

In the decay process, this excess of mass is converted into energy of other forms and appears in the form of kinetic energy of both the daughter nucleus and the alpha particle. Most of kinetic energy is carried away by the alpha particle because it is much less massive than the daughter nucleus. The momentum is conserved in this process.

The isotope whose natural radioactive decay involves the emission of alpha particles usually have a relative atomic mass greater than 210 ( $A_r > 210$ ). They have too much mass to be stable and give out alpha particles to form smaller and more stable atoms.

Example 1: Radium 226 (Ra) decays with the emission of an  $\alpha$ -particle to form an inert gas radon (Rn)  ${}_{86}^{222}\text{Rn}$

The transformation is given by  ${}^A_Z X \rightarrow {}^{A-4}_{Z-2} Y + {}^{222}_2 \text{Rn}$

Example 2:  ${}^{226}_{88}\text{Ra} - {}^4_2\text{He} + {}^{222}_{86}\text{Rn}$  Or  ${}^{226}_{88}\text{Ra} - {}^4_2\text{He} + {}^{222}_{86}\text{Rn}$

where  ${}^4_2\text{He}$  is alpha particle. Both the mass ( $226 - 4 = 222$ ) and the charge ( $88 - 2 = 86$ ) must be conserved.

Radon is also unstable, and decays with the emission of an alpha particle:

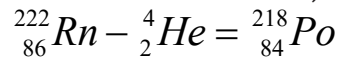

Polonium is also an alpha particle emitter  ${}^{218}_{82}\text{Po} - {}^4_2\text{He} = {}^{214}_{80}\text{Pb}$

## b. Beta decay

The isotopes whose radioactive decay involves the emission of beta particles often have a relative atomic mass less than 210 ( $A_r < 210$ ). Beta particles are usually emitted from heavier nuclei that have too many neutrons compared with the number of protons.

### I. Negative $\beta$ -decay

In this process of negative  $\beta$ -decay an electron and an antineutrino are emitted.

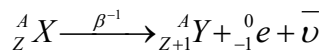

Examples of negative  $\beta$  emitters are given below

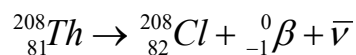

The emitted electron results from the following reaction where a neutron changes into a proton and an electron is emitted from the nucleus as a beta particle:

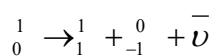

The conservation of charges and mass number is maintained. The daughter nuclide may be in an excited state and will become stable after emitting a  $\gamma$ -ray.

## II. Positive $\beta$ -decay

In this process the positron and the neutrino are emitted.

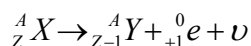

This positive decay is different from an electron capture which takes place when an electron that is close to the nucleus recombines with a proton in the nucleus producing a neutron and a neutrino:

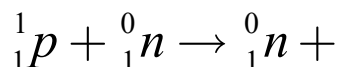

The equation of decay of the electron capture is:

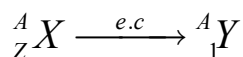

The daughter nuclide is seem to be the same as that we could have been produced if a positron has been emitted. The rearrangement of the remaining  $Z-1$ electrons will lead to emission of characteristic x-ray of the daughter nucleus. In few case both positron and electron capture may happen.

## C. Gamma decay ( $\gamma$ )

Very often a nucleus that undergoes radioactive decay is left in an excited energy state. The nucleus can then undergo a second decay to a lower energy state by emitting one or more photons. Unlike  $\alpha$  and  $\beta$  decay,  $\gamma$  decay results in the production of photons that have zero mass and no electric charge. The photons, emitted in such process, are called **gamma rays** and they have very high energy.

If an atom of a material  $Y$  emits a  $\gamma$  ray ( $\gamma$  photon), then the nuclear reaction can be represented symbolically as

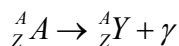

Gamma emission does not result in any change in either  $Z$  or  $A$ .

### Notes:

- A transmutation does not occur in gamma decay. When an alpha particles and beta particles are emitted, gamma rays are often emitted at the same time. When a radioisotope emits gamma rays, it become more stable because it loses energy.
- In both alpha and beta decay, the new element formed is called **the daughter isotope**.

- Gamma rays are like X-rays. Typical gamma rays are of a higher frequency and thus higher energy than X-rays.
- Deviations of alpha, beta and gamma radiations due to electric field and magnetic field ( See Fig.4.9). It can be seen unlike gamma-rays, alpha and  $\beta$ -particles are affected by the presence of electric and magnetic fields since these particles are charged. Gamma-rays are not affected by these fields.

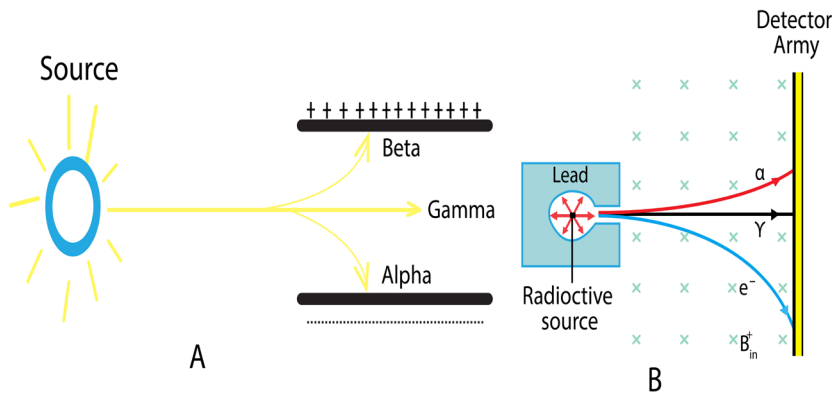
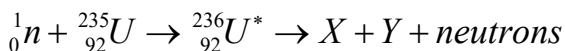

Fig.4. 8: Deviation of radiation particles in an electric field

### 4.3.3 Nuclear fission and Fusion

#### a. Nuclear fission

Heavy unstable nuclides can be broken up to produce energy in a process called nuclear fission. When uranium decays naturally, alpha and beta particles are emitted. However, when uranium-235 is bombarded by neutrons it forms uranium-236. Uranium-236 is unstable and breaks down, splitting into two large particles and emitting three neutrons. The fission of  $^{235}\text{U}$  by thermal neutrons can be represented by the reaction



where  ${}^{236}\text{U}^*$  is an intermediate excited state that lasts for approximately 10-12s before splitting into medium-mass nuclei X and Y, and these are called fission fragments.

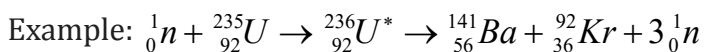

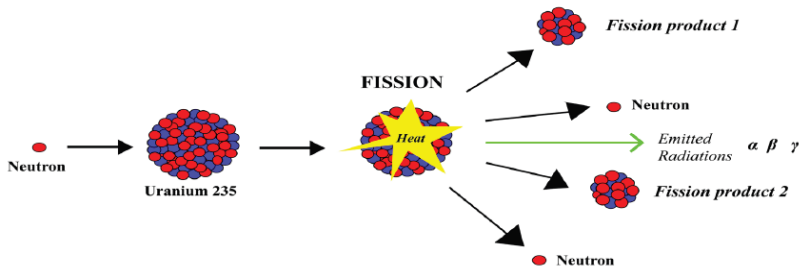

Fig.4. 9: Fission diagram illustration

When the exact masses of the final products are added together, the sum is found to be appreciably less than the exact masses of the uranium-235 and the original neutron. This difference in mass  $\Delta m$  appears as energy given by

$$\Delta m = \Delta mc^2$$

Another important point arises! The three neutrons released may collide with other nuclides and split them also resulting in cascade reactions. In this way, chain reactions occur and as a result, the quantity of energy released can be very large. A few kilogram of uranium can produce as much heat energy as thousands of tons of coal.

### Advantages and disadvantages of nuclear fission

The nuclear fission produces a huge amount of energy. This energy can be released in a controlled manner in nuclear power station and be used in driving steam turbines that produce electric power. However, when produced in uncontrolled manner it will result in the fabrication of atomic bomb that may release a large amount of heat energy and damaging radiations. The emitted radiations have both short term and long term effect on the living things.

### b. Nuclear fusion

When lighter nuclides merge together in a process called fusion, energy is produced and mass is lost. For example:  ${}^2_1\text{H} + {}^1_1\text{H} \rightarrow {}^3_2\text{He} + {}^1_0\text{n}$

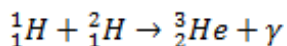
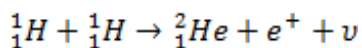

These reactions occur in the core of a star and are responsible for the outpouring of energy from the star.

The sum of the exact masses of the helium atom is less than the sum of exact masses of the four hydrogen atoms. This lost mass is released as energy. It is thought that the sun's energy is produced by nuclear fusion.

#### 4.3.4 Radiation detectors

##### ACTIVITY 4.4: Smoke detector bellow

Observe the diagram of a smoke detector bellow then answer to the questions that follow:

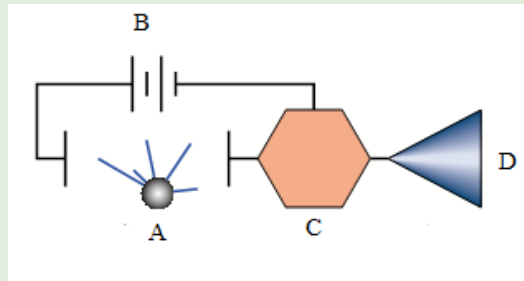

Fig.4. 10: illustration diagram of a smoke detector

1. Name the components labeled A, B, C and D on the smoke detector above?
2. What is meant by smoke detector?
3. Describe a functioning of a smoke detector.
4. Design an inventory of other radiation detectors you know

Experiments in Nuclear and Particle Physics depend upon the detection of primary radiation/particle and that of the product particles if any. The detection is made possible by the interaction of nuclear radiation with atomic electrons directly or indirectly.

##### a. Classification of radiation detectors

There are a variety of other radioactive detectors that we may conveniently classify into two classes: **Electrical and Optical detectors.**

Types	Detector
Electric	<ul style="list-style-type: none"> <li>• Ionization Chamber</li> <li>• Proportional Counter</li> <li>• Geiger-Müller Counter</li> <li>• Semi-conductor detector</li> <li>• Neutron Detector</li> <li>• Scintillation Counter</li> <li>• Cerenkov Counter</li> </ul>

Optical	<ul style="list-style-type: none"> <li>• Photographic Emulsion</li> <li>• Expansion Cloud Chamber</li> <li>• Diffusion Cloud Chamber</li> <li>• Bubble Chamber</li> <li>• Spark Chamber</li> </ul>
---------	--

Table4. 1 Classification of radiation detectors

### b. Working principle of an ionization chamber

Conventionally, the term “ionization chamber” is used exclusively to describe those detectors which collect all the charges created by direct ionization within the gas through the application of an electric field. Ionization chamber is filled with inert gases at low pressure. In the chamber there are two electrodes, namely, the cathode and the anode which are maintained at a high potential difference as shown on the figure below

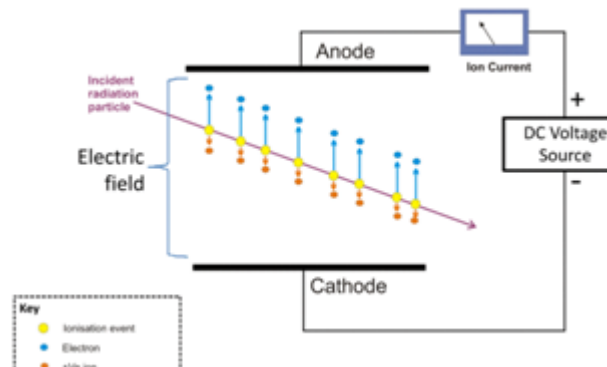

Fig,4.11: visualization of ion chamber operation

When radiation enters the chamber, it ionizes the gas atoms creating negative and positive charges. The negative charges or electrons are attracted by the anode while positive ions are attracted by the cathode; this produces the current in the outside circuit depending on the strength and the type of radiation. The current produced is quite small and dc amplified electrometers are used to measure such small currents.

### 4.3.5 Checking my progress

In the following exercises (1 to 4), choose the best answer and explain your choice

- Which of the following is an electron?
  - Neutrino
  - Gamma particle
  - Photon
  - Beta particle
- Which of the following most accurately describe radioactive decay?
  - Molecules spontaneously break apart to produce energy
  - Atoms spontaneously break apart to produce energy beta decay, alpha decay and positron emission are all forms of radioactive decay. Energy is released because the atoms are converted to a more stable energy
  - Protons and neutrons spontaneously break apart to produce energy
  - Electrons spontaneously break apart to produce energy
- Which of the following is true concerning the ratio neutrons to protons in stable atoms?
  - The ratio for all stable atoms is 1:1.
  - The ratio for small stable atoms is 1:1, and the ratio for large stable atom is greater than 1:1. As atomic weight goes up, the ratio of neutrons to protons for stable atoms increases up to as much as 1.8:1 ratio.
  - The ratio for large stable atom is 1:1, and the ratio for small stable atoms is greater than 1:1.
  - There is no correlation between the stability of the atom and its neutron to proton ratio.
- Polonium-218 undergoes one alpha decay and two beta decays to make
  - Polonium-214
  - Plomb-214
  - Bismuth-214
  - Plomb-210
- a) Compare (i) the charge possessed by alpha, beta and gamma radiations  
(ii) The penetrating power of these radiations
- a. What is meant by the term (i) radioactive decay? (ii) Half-life of a radioactive substance?  
b. A 32 g sample of radioactive material was reduced to 2 g in 96 days. What is its half-life? How much of it will remain after another 96 days?
- $^{212}\text{Be}$  Decays to  $^{208}\text{Th}$  by  $\alpha$ -emission in 34% of the disintegration and to  $^{212}\text{Ra}$  by  $\beta$ -emission in 66% of the disintegration. If the total half value period is 60.5 minutes, find the decay constants for alpha and beta and the total emission.
- If a radioactive material initially contains 3.0 milligrams of Uranium  $^{234}\text{U}$ , how much it will contain after 150,000 years? What will be its activity at the end of this time?

## 4.4 APPLICATION OF RADIOACTIVITY

### ACTIVITY 5.5: Use of nuclear energy to generate electricity

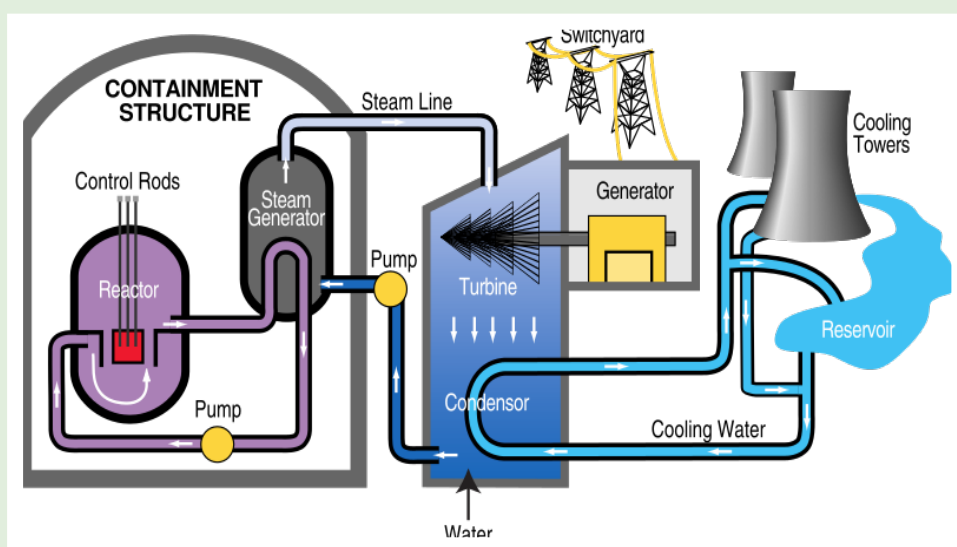

Fig.4. 12: Nuclear power plant functioning mechanism diagram.

Many people disagree to the use of nuclear power to generate our electricity, even though the safety record of nuclear industry is extremely good. Observe clearly the image diagram of the nuclear power plant (Fig.4.12) and answer to the questions that follow

1. Why do you think people disagree to the use of nuclear power station?
2. What are the main parts of the power plant station observed in Fig.5.12?
3. Analyze and explain the steps of energy transformation from reactor to generator
4. Write a brief explanation on the advantages and disadvantages of using nuclear energy as a source of electricity if any.
5. Use internet and your library or any other resources to find out about the other application of radionuclides in our daily life

People would not have fear of radiations when controlled in certain manner. Radioisotopes and nuclear power process have been used and produced improvement in various sectors. These includes: consumer products, food and agriculture, industry, medicine and scientific research, transport, water resources and the environment. The following are some descriptive examples among others.

### 4.4.1 Industry

Different materials we use at home are manufactured in industry and made of different radioactive materials. The dosage of use of radioactive substance is thus controlled so that they are not harmful to human body.

Gamma radiation and beta radiation from radio-isotopes can be used to monitor the level of the material inside the container. The penetrating power of gamma rays is used to detect hidden flow in metal castings. Beta rays are used to measure the thickness of various flat objects (the mass absorbed by the object is proportional to its thickness).

In the textile industries, irradiation with beta radiations fixes various chemicals onto cotton fibers. This produces for instance permanent press clothing. Again, radioactive materials can be used as tracers to investigate the flow of liquids in chemical factories.

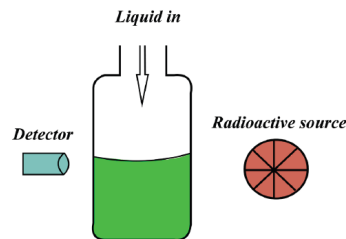

Fig.4. 13 Testing the level of a liquid in a container using radiations

If there is a sudden decrease in the amount of radiation reaching the detector, which will happen when the container is full, then this can be used as a signal to switch off the flow of substance into the container. A similar method is used to monitor the thickness of sheets of plastic, metal and paper in production.

### 4.4.2 Tracer studies

Tracer techniques can be used to track where substances go to and where leaks may have occurred. Leaks in gas pipes or oil pipes can be detected by using this technique. Tracer techniques are also used in medicine to treat thyroid glands which can be underactive or over active. The activity of the thyroid gland can be monitored by the patient being injected with or asked to drink radioactive iodine. The radioactivity in the vicinity of the thyroid gland is then checked to see how much of the radioactive iodine has settled in the area around the gland.

### 4.4.3 Nuclear power stations

Nuclear power stations control a large amounts of energy released when Uranium-235 undergoes nuclear fission. The energy released by this controlled chain reaction, is then used to produce electricity.

#### 4.4.4 Nuclear fusion

In nuclear fusion, the nuclei of elements with a very low atomic number are fused together to make heavier elements. When this takes place, it is accompanied by a very large release of energy. In the sun, hydrogen nuclei are fusing together all the time to make helium nuclei. This is also the process by which a hydrogen bomb works.

#### 4.4.5 Medicine

### ACTIVITY 4.6: Radionuclides in Medicine

Observe the figure below and suggest answers to the question below

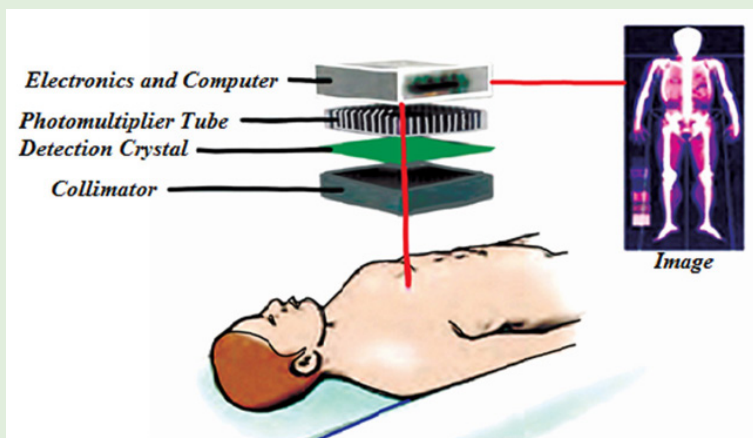

*Fig.4. 14: A gamma camera assembly. The photons emitted in the patients are detected by the photomultiplier tubes. A computer monitor displays the image computed from the photomultiplier signals.*

1. Who is this person (a man or a woman)?
2. Where is he?
3. What does the image on the right represent?
4. What do you think the patient is suffering from?
5. Using the knowledge acquired in optics, what kind of light propagation observed there?
6. Does the imaging use reflection or refraction? Why?
7. What should be the name of radiation being used in this imaging?

Nuclear medicine has revolved treatment of different disease of the century. It consists on the use of nuclear properties of radioactive substances in diagnosis, therapy and research to evaluate metabolic, physiologic and pathologic conditions of human body. Today, nuclear medicine is currently used in the diagnosis, treatment and prevention of many serious sicknesses.

Cancer cells are more easily killed by radiation than healthy cells. In medicine, penetrating gamma rays of cobalt-60 sources are used for this purpose. Other cancers such as skin cancers are treated by less penetrating beta radiation from strontium-90 source. Surgical instruments can also be sterilized using gamma radiation.

#### 4.4.6 Food preservation

The preservation of food uses gamma rays is spreading worldwide. Treating food with gamma rays can:

- Slow down the ripening of some fruits and the sprouting of potatoes. In both cases, this helps storage and increases the half-life of the food.
- Kill highly dangerous micro-organisms such as salmonella
- Kill micro-organisms that spoil food

#### 4.4.7 Radiocarbon dating

There are three isotopes of carbon: carbon-12, carbon-13 and carbon-14. The isotope carbon-14 is radioactive and has half-life of 5760 years. To estimate the age of a biological sample, radiocarbon  $^{14}_6C$  is used as a radioactive nuclide. Nucleus decay is independent of the physical or chemical condition imposed on the elements. This can be used to measure the ages of biological samples by considering the ratio of  $^{14}_6C$  which is radioactive and  $^{12}_6C$  in dead species. Radioactive carbon is produced when cosmic rays interact with air atoms to produce neutrons and these neutrons interact with nitrogen

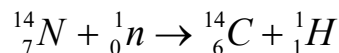

The half-life period of  $^{14}_6C$  is equal to 5760 years. The carbon reacts with oxygen to produce CO<sub>2</sub> and plants combine this CO<sub>2</sub> with water in the process of photosynthesis to manufacture their food. Therefore plants and animals are radioactive. When plants or animals die, the  $^{14}_6C$  in them keeps on decaying without any new intake. The ratio of  $^{14}_6C$  and  $^{12}_6C$  will therefore be different in dead and living plants and animals. The age of the dead plant or animal can be estimated by measuring this ratio.

Radioactive substance	Material tested	Half-life (years)	Potential range (years)
Carbon 14	Wood, charcoal, shell	5730	70000
Protactinium 231	Deep sea sediment	32000	120000
Thorium 230	Deep sea sediment, coral shell	75000	400000
Uranium 234	Coral	250000	1000000
Chlorine 36	Igneous and volcanic rocks	3000000	500000

Beryllium 10	Deep sea sediment	2.5 billion	800000
Helium 4	Coral shell	4.5 billion	-
Potassium 40	Volcanic ash (containing decay product of argon 40)	1.3 billion	-

Table 4. 4 Half-life of some radioactive substances

#### 4.4.8 Agricultural uses

In agriculture, radionuclides are used as tracers for studying plants, insect and animals. For example, phosphorus-32 can be added to plant fertilizer. Phosphorus is absorbed by plants and its distribution can be measured. Radiation has been used in South American to detect and control the screw worm fly pest. A large number of the male of the species were exposed to gamma radiation. When the males were released back into the wild and mated with wild females, sterile eggs resulted and no new flies were born.

The points of photosynthesis in a leaf are revealed by growing it in air containing carbon-14. The presence of this radioactive nuclide in the leaf is the revealed by putting the leaf onto a photographic plate and letting it take its own picture.

#### 4.4.9 Checking my progress

1. Suggest different uses of radionuclides in (i) Medicine (ii) food and agriculture
2. In our daily life, we are exposed to radiations of different types mainly in materials we use.
  - a. Make an inventory of all of the devices in your home that may have (contain) a radioactive substance.
  - b. What is the origin of these radiations in the materials highlighted above?
  - c. Explain the purpose of radioactive material in the device.
  - d. Then make research to find out how the objects shown in Fig.5.15 use radiation in their manufacture.



Fig.4. 15

## 4.5 HAZARDS AND SAFETY PRECAUTIONS OF WHEN HANDLING RADIATIONS

### ACTIVITY 4.7: Investigating the safety in a place with radiations

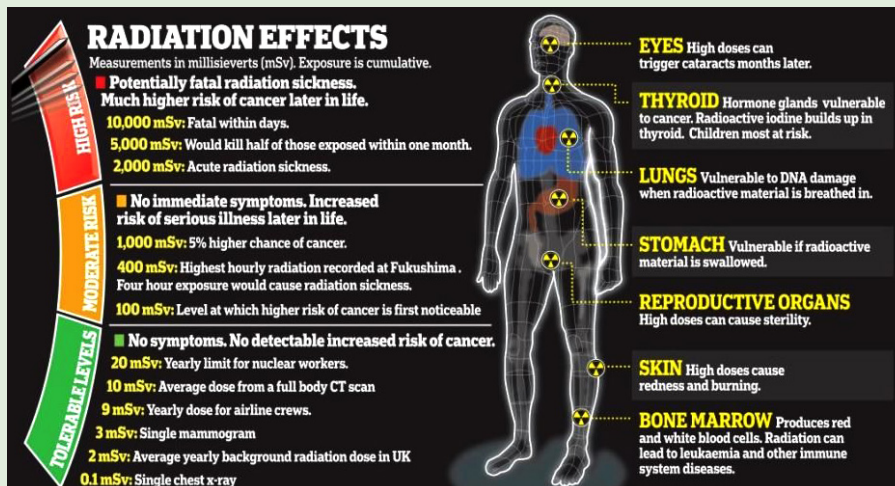

Fig.4. 16: Radiation effects on human body according to the exposure.

The image above (Fig.4.16) shows different side effects of radiation on human body according to the exposure time taken. With reference to section 4.3 and activity 4.3, answer to the following questions:

1. What are the dangers of radiations you may observe?
2. Analyze measures should be taken for radiation users?

#### 4.5.1 Dangers of radioactivity

- Both beta particles and gamma rays can pass easily in the skin and can easily destroy or even kill cells, causing illness.
- They can cause mutations in a cell's DNA, which means that it cannot reproduce properly, which may lead to diseases such as cancer.
- Alpha particles cannot pass through the skin. However, they are extremely dangerous when they get inside your body. This can happen if you inhale radioactive material.

#### 4.5.2 Safety precautions when Handling Radiations

The precautions taken by workers who deal with radioactive materials are:

- Wearing protective suits
- Wearing radiation level badges
- Checking the radiation level regularly

- Using thick lead-walled containers for transporting radioactive materials
- Using remote control equipment from behind thick glass or lead walls to handle radioactive material
- They should be held with forceps and never touched with hands.
- No eating, drinking or smoking where radioactive materials are in use
- Wash your hands thoroughly after exposure of to any radioactive materials
- Any cuts in the body should be covered before using radioactive sources
- Arrange the source during experiments such that the radiation window points away from your body
- There are ten golden rules for working safely with radioactivity.

Rule	Other considerations
1. Understand the nature of the hazard and get practical training.	Never work with unprotected cuts or breaks in the skin, particularly on the hands or forearms. Never use any mouth operated equipment in any area where unsealed radioactive material is used. Always store compounds under the conditions recommended. Label all containers clearly indicating nuclide, compound, specific activity, total activity, date and name of user. Containers should be properly sealed.
2. Plan ahead to minimize time spent handling radioactivity.	Do a dummy run without radioactivity to check your procedures. The shorter the time the smaller the dose.
3. Distance yourself appropriately from sources of radiation.	Doubling the distance from the source quarters the radiation dose [Inverse square law].
4. Use appropriate shielding for the radiation.	1 cm Perspex will stop all betas but beware of bremsstrahlung x-rays from high energy beta emitters. Use a suitable thickness of lead for X and gamma emitters.
5. Contain radioactive materials in defined work areas.	Always keep active and inactive work separated as far as possible, preferably by maintaining rooms used solely for radioactive work. Always work over a spill tray and work in a ventilated enclosure except with small (a few tens of MBq) quantities of $^3\text{H}$ , $^{35}\text{S}$ , $^{14}\text{C}$ and $^{125}\text{I}$ compounds in a non-volatile form in solution.

6. Wear appropriate protective clothing and dosimeters.	For example, laboratory coats, safety glasses, surgical gloves and closed top footwear. However beware of static charge on gloves when handling fine powders. Local rules will define what dosimeters should be worn e.g. body film badge, thermoluminescent extremity dosimeter for work with high energy beta emitters, etc.
7. The work area frequently for contamination control.	<p>In the event of a spill - follow the prepared contingency plan:</p> <ul style="list-style-type: none"> <li>• Verbally warn all people in the vicinity</li> <li>• Restrict unnecessary movement into and through the area</li> <li>• Report the spill to the School Radiation Safety Officer</li> <li>• Treat contaminated personnel first</li> <li>• Follow clean up protocol.</li> </ul>
8. Follow the local rules and safe ways of working.	Do not eat, drink, smoke or apply cosmetics in an area where unsealed radioactive substances are handled. Use paper tissues and dispose of them appropriately. Never pipette radioactive solutions by mouth. Always work carefully and tidily.
9. Minimise accumulation of waste and dispose of it by appropriate routes.	Use the minimum quantity of radioactivity needed for the investigation. Disposal of all radioactive waste is subject to statutory control. Be aware of the requirements and use only authorised routes of disposal.
10. After completion of work – monitor yourself, wash and monitor again	Never forget to do this. Report to the School Radiation Safety Officer if contamination is found.

Table 4. 5

## END UNIT ASSESSMENT 4

### A. Multiple choice questions

Instructions: Write number 1 to 5 in your notebook. Beside each number, write the letter corresponding to the best choice

1. Radionuclides
  - a. Are those nuclides having more neutrons than protons
  - b. May emit X-rays.
  - c. Decay exponentially
  - d. May be produced in a cyclotron
2. Concerning Compton Effect:
  - a. There is interaction between a photon and a free electron.
  - b. The larger the angle through which the photon is scatted, the more energy it loses.
  - c. The wavelength change produced depends upon the scattering material.
  - d. High energy radiation is scatted more than lower energy radiations.
  - e. The amount of scattering that occurs depends on the electron density of the scattering material.
3. Classical physics offered a satisfactory explanation for
  - a. The diffraction of electrons by crystals
  - b. The deflection of charged particles in an electric field
  - c. The intensity spectrum of black body radiation
  - d. The photoelectric effect
  - e. Matter waves
4. When investigating  $\beta$  decay, the neutrino was postulated to explain
  - a. Conservation of the number of nucleons
  - b. Counteracting the ionizing effect of radiation
  - c. Conservation of energy and momentum
  - d. The production of antiparticles
  - e. The energy to carry away the  $\beta$  particles.
5. Gamma radiations differ from  $\alpha$  and  $\beta$  emissions in that
  - a. It consist in photons rather than particles having nonzero rest mass

- b. It has almost no penetrating ability
- c. Energy is not conserved in the nuclear decays producing it
- d. Momentum is not conserved in the nuclear decays producing it
- e. It is not produced in the nucleus

6. The process represented by the nuclear equation is  ${}_{90}^{230}\text{Th} \rightarrow {}_{88}^{226}\text{Ra} + {}_2^4\text{He}$

- a. Annihilation
- b.  $\alpha$  decay
- c.  $\beta$  decay
- d. pair production
- e.  $\gamma$  decay

7. Write number (i) to (iii) in your note book. Indicate beside each number whether the corresponding statement is true (T) or false (F). If it is false, write a corrected version.

- I. An alpha particle is also called a hydrogen nucleus
- II. The neutrino was suggested to resolve the problem of conserving energy and momentum in  $\beta$  decay.
- III. The amount of energy released in a particular  $\alpha$  or  $\beta$  decay is found by determining the mass difference between the products and the parent. A mass-energy equivalence calculation then gives the energy.
- IV. The average binding energy per nucleon decreases with the increasing atomic mass number

8. A radioactive source emits radiations alpha, beta and gamma as shown below:

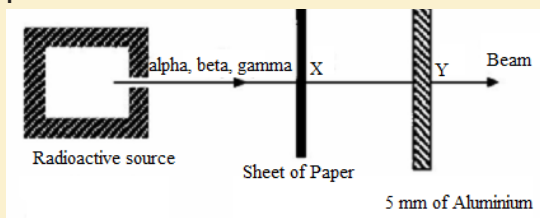

Fig.4. 17 Absorption of radiation

The main radiation(s) in the beam at X and Y are

	Position X	Position Y
A	Alpha and beta	Beta
B	Beta and gamma	Beta
C	Alpha and gamma	Gamma
D	Alpha and beta	Alpha
E	Beta and gamma	Gamma

Table 4. 6 Radiation

9. The energy released by the nuclear bomb that destroyed Hiroshima was equivalent to 12.4 kilotons of TNT. This is equivalent to  $9.1 \times 10^{16}$  MeV. The mass that was converted into energy in this explosion was (Convert MeV in Joules, use  $E=mc^2$ )

- a. 1.6 kg  
 b.  $1.6 \times 10^{-3}$  kg  
 c.  $1.4 \times 10^{14}$  kg  
 d.  $1.1 \times 10^{10}$  kg  
 e. 120 kg

10. In the decay scheme (Conserve charge and electron lepton number) the blanks should contain

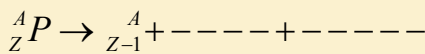

- a.  $\beta^+$  and n  
 b.  $\beta^-$  and  $\nu$   
 c.  $\beta^-$  and p  
 d.  $\beta^+$  and  $\nu$   
 e.  $\beta^+$  and  $\beta^-$
11. Complete the following sentences by using a word, number and an equation where necessary

a. The half-life in years of the decay represented by the graph in fig.4.18

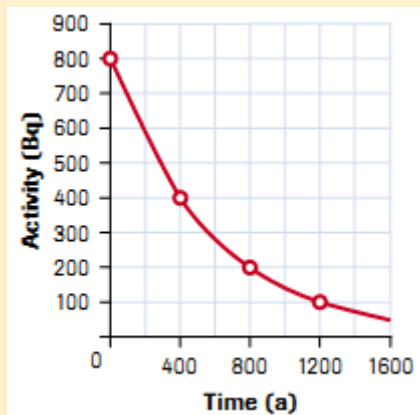

Fig.4. 18 Half life curve

- b. When an animal or plant dies, no more \_\_\_\_\_ is taken in and that which is present undergoes radioactive decay. If we measure the amount of carbon-14 left, it is possible to determine the \_\_\_\_\_ of the sample.
- c. If an atom of material Y emits a gamma ray (gamma photon), then the nuclear reaction can be represented symbolically as \_\_\_\_\_

## B. Structured questions

12. Prepare a table summarizing the three types of radioactive emission. Classify each type under the following headings: Type of Emission, Mass, Charge, penetrating Power and Ionization Ability.
13. Copy the following table in your notebook and answer the questions that follow

a. What are the properties of alpha radiation?	
b. How do you calculate the half-life from a graph?	
c. What is the difference between contamination and irradiation?	
d. How should radioactive samples be handled safely?	

14. Give the value of  $x$  and  $y$  in each of the following equations

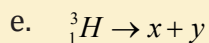
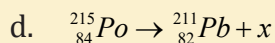
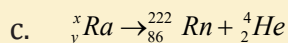
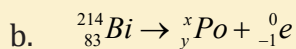
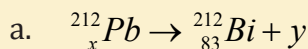

15. Give the value of  $x$  and  $y$  in each of the reaction classify each as  $\alpha$ ,  $\beta$ , or  $\gamma$  decay.

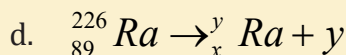
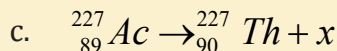
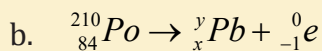
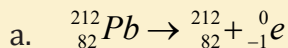

16. The half-life of carbon-14 is 5730 years. The mass of a certain sample of this isotope is  $800 \mu\text{g}$ . Graph the activity for the first 5 half-lives.

17. Beams of  $\alpha$ ,  $\beta^-$  and  $\gamma$  radiation of approximately the same energy pass through electric and magnetic fields as shown below.

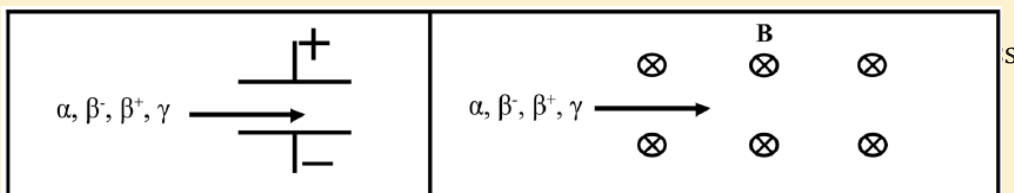

Fig.4. 19 Deflection of radiations

- Show the path taken by each particle in the two fields. Why do they follow these paths?
  - Which particle is the most penetrating? Explain your answer.
  - Which has the highest ionizing power?
  - How are  $\beta^-$ ,  $\beta^+$  and electrons different?
  - How are x-rays,  $\gamma$  rays and photons different?
18. We are exposed to radiation all the time, indoors and outdoors. This is called background radiation.
- Give two examples of sources of this background radiation.
  - Which organ generally receives the most background radiation, and why?
  - There is some concern at the moment that pilots and flight attendants may have significantly higher exposures to radiation than the normal exposure rates for the general public.
  - Why do pilots have a higher exposure to radiation than most other people?
19. Nuclei can decay by emitting particles which can change the energy, mass and charge of the nucleus.
- How is  $\alpha$  decay possible when the  $\alpha$  particle must pass an energy barrier which is greater than the energy of the particle? Describe the process involved.
  - If isotope A emits  $\alpha$  particles with greater energy than isotope B (of the same element), which will have the longer half-life?
  - How can a nucleus change its charge without emitting a charged particle?

**20.** Nuclear power is used in many places in the world. There are over 400 nuclear power plants currently in operation, over 100 of which are in the USA, providing 20% of the electricity consumed in that country. These plants use uranium fuel ( $^{238}_{92}\text{U}$  enriched with 3%  $^{235}_{92}\text{U}$ ) to produce electricity. It is the fission of the  $^{235}_{92}\text{U}$  nuclei which provides the majority of the thermal energy that is used to generate the power.

- Complete the following decay equation:  $^{235}_{92}\text{U} + \text{n}$   
 $^{93}_{37}\text{Rb} + ^{141}_{55}\text{Cs} + \underline{\hspace{2cm}}$
- Use the data in the table below to find the energy released in this reaction.
- How many decays per second would it take to run a 60 W light globe?
- If a power plant only converts 10% of the excess mass into useful energy, how many decays per second would you need?

Useful masses:

Particles	$^{235}_{92}\text{U}$	$^{93}_{37}\text{Rb}$	$^{141}_{55}\text{Cs}$	$^4_2\alpha$	b	g
Mass (amu)	235.04392	92.92172	140.91949	4.002603	0.000545	0.0000000

$$1 \text{ amu} = 1.660566 \times 10^{-27} \text{ kg.}$$

### C. Question of research

- Using the information in radioactivity and making an internet search or/ and using other sources of information, consolidate your skills in other hazardous materials you may meet in your area. Then complete the table below (not exhaustive):





Types of compounds +description	Symbol	Risks	Precautions
Compressed gas <ul style="list-style-type: none"> <li>Material that is normally gaseous and kept in a pressurized container.</li> </ul>			
Flammable and combustible materials <ul style="list-style-type: none"> <li>Material that continue to burn when exposed to a flame or near an ignition source</li> </ul>			
Toxic materials immediate and severe <ul style="list-style-type: none"> <li>Poisons and fatal materials that cause severe and immediate harm</li> </ul>			
Bio hazardous infectious materials <ul style="list-style-type: none"> <li>Infectious agents or biological toxin causing a serious disease and death</li> </ul>			
Corrosive materials <ul style="list-style-type: none"> <li>Materials which react with metals and living tissue</li> </ul>			

Table 4. 7 Precaution signs

# UNIT 5

## APPLICATIONS OF OPTICAL FIBER IN TELECOMMUNICATION SYSTEMS.



**Key unit competence:** Differentiate optical fiber transmission and other transmitting systems.

### My goals

- Explain the functioning of optical fiber
- Explain attenuation in optical fiber
- Identify and explain the components of optical fiber system
- Solve problem related to attenuation giving answers in decibels
- Describe telecommunication system
- Describe functions of amplifiers in optical fiber transmission
- Distinguish optical fiber and other telecommunication systems

## INTRODUCTORY ACTIVITY

### Investigating the use of optical fiber in RWANDA

Rwanda plans to connect three million people to the World Wide Web as part of the “Internet for All” project. The project is a World Economic Forum initiative that aims to connect 25 million new Internet users in Kenya, Uganda, South Sudan and Rwanda by 2019.

This goal will partly be achieved by addressing the challenges of affordability, digital skills gap, lack of local content and limited infrastructure, which are hindering growth in the use of Internet across the region (<http://www.threastafrican.co.ke>, 2017)

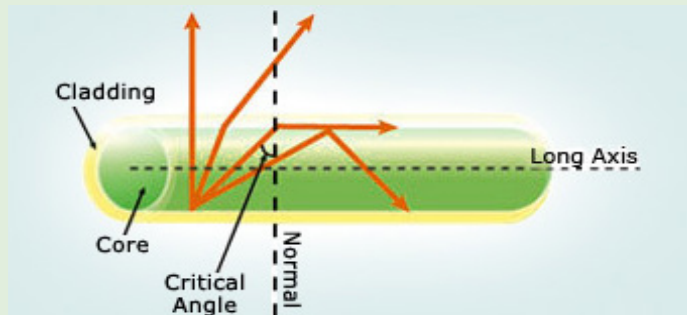

*Fig.5. 1: The installation and use of optical fiber in Rwanda*

1. Observe the images A, B and C (Fig.5.1) and describe what you can see.
2. What are the uses of optical fiber in transmission of signals?
3. How do optical fibers function? In which field?
4. Discuss other applications of optical fibers.

## 5.1 PRINCIPLES OF OPERATIONS OF OPTICAL FIBERS

### ACTIVITY 5.1: Total internal reflection in optical fiber.



*Fig.5. 2: The total internal reflection in the optical fiber*

Given the illustration above (Fig.5.2), one can see different rays inside the optical fiber.

As the angle of incidence in the core increases, as the angle of refraction increases more until it becomes right angle at a certain value of incidence angle called **critical angle**. Discuss:

1. What do you understand by the term critical angle?
2. What causes the total internal reflection?
3. Discuss different fields where total internal reflection can be useful.

### 5.1.1 Definition

An optical fiber (fiber optics) is a medium for carrying information from one point to another in the form of light. It uses a flexible, transparent fiber made by drawing glass or plastic and has a diameter slightly thicker than that of a human hair. They are arranged in bundles called **optical cables** and can be used to transmit signals over long distances. Fiber optics continues to be used in more and more applications due to its inherent advantages over copper conductors.



Fig.5. 3: An optical cable and a bundle of optical fibers

An optical fiber is made of 3 concentric layers:

- **Core:** This central region of the optical fiber is made of silica or doped silica. It is the light transmitting region of the fiber.
- **Cladding:** This is the first layer around the core. It is also made of silica, but not with the same composition as the core. This creates an optical waveguide which confines the light in the core by total internal reflection at the core-cladding interface.
- **Coating:** The coating is the first non-optical layer around the cladding. The coating typically consists of one or more layers of polymer that protect the silica structure against physical or environmental damage.

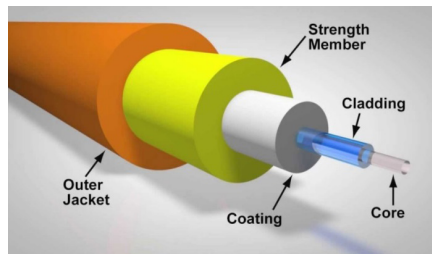

Fig.5. 4: the structure of optical fiber

The light is guided down the core of the fiber by the optical cladding which has a lower refractive index. Remember that the refractive index is the ratio of the velocity of light in a vacuum to its velocity in a specified medium. Then light is trapped in the core through total internal reflection. The other outer parts that are the **strength member** and the **outer jacket**, serve as protectors.

Connecting two optical fibers is done by fusion splicing or mechanical splicing. It requires special skills and interconnection technology due to the microscopic precision required to align the fiber cores.

### 5.1.2 Refractive index of light

When light falls at the interface (boundary) of two media, it is partially reflected and partially refracted. As it passes from one medium to another it changes its direction.

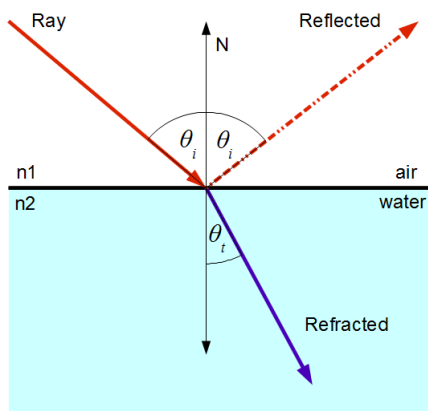

Fig.5. 5: Refraction of light from air to water and water to air for comparison.

The change in its direction is associated with the change in velocity. The ratio of the speed of light in the vacuum  $c$  (or air) and that of light in a certain medium  $v$  is called the absolute refractive index  $n$ .

$$n = \frac{c}{v} \tag{5.01}$$

### 5.1.3 Total internal reflection

When light passes from one a medium of higher index of refraction into a medium of lower refractive index the light bends away from the normal as indicated on Fig.6.6. A weak internally reflected ray is also formed and its intensity increases as the incident angle increases.

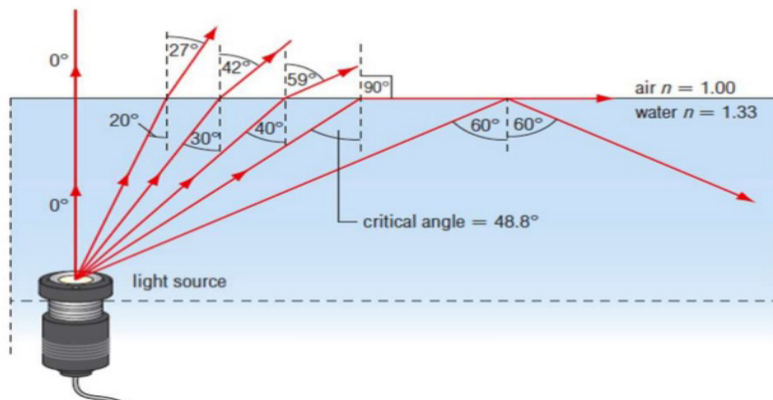

Fig.5. 6: Illustration of total internal reflection

Increasing the angle of incidence increases the angle of refraction and at a particular incidence, the angle of refraction reaches the  $90^\circ$ . This particular incident angle is called the **critical angle**  $\theta_c$ . As the incident angle exceeds the critical angle, the incident beam reflects on the interface between the 2 media and return in the first medium. This effect is called **total internal reflection**. For any two media, using Snell's law the critical angle is calculated using the

expression 
$$\sin \theta_c = \frac{n_2}{n_1} \quad (5.02)$$

where  $n_1$  and  $n_2$  are respectively the refractive indices of the first and second media.

$\theta_c$  increases when approaches  $n_1$ .

### EXAMPLE 5.1

Applying the above relation to the critical ray at a glass-air boundary we have where index of glass is  $n_g = 1.50$ .

Answer

$$\sin \theta_c = \frac{1}{1.5} \Leftrightarrow \theta_c = 42^\circ$$

A beam of light is propagating through diamond,  $n = 2.42$  and strikes a diamond-air interface at an angle of incidence of  $28^\circ$ .

Will part of the beam enter the air or will the beam be totally refracted at the interface?

Repeat part (a) assuming that diamond is surrounded by water,  $n = 1.33$

**Answer:**

a.  $\sin \theta_c = \frac{1}{2.42} \Leftrightarrow \theta_c = 24.4^\circ$

Since  $28^\circ$  is greater than  $\theta_c$ , total internal reflection will occur, there is no refraction.

b.  $\sin \theta_c = \frac{1.33}{2.42} \Leftrightarrow \theta_c = 33.3^\circ$

Since  $28^\circ$  is less than  $\theta_c$  some light will undergo refraction into the water.

**Application:**

An optical fiber is basically made of 2 types of glass put together in a concentric arrangement so the middle is hollow. The inner circle of glass also called the Core consists of a glass of higher refractive index than the outside layer as indicated on fig.5.4.

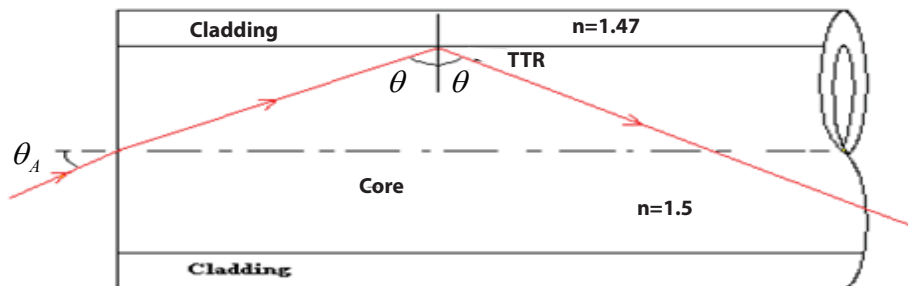

Fig.5. 7: Total internal reflection in optical fiber as the angle of incidence  $\theta$  is greater than the critical angle.

The outer layer of glass, which is also known as the optical cladding, does not carry light but is essential to maintain the critical angle of the inner glass. The underlying main physics concept behind the functioning of an optical fiber is a phenomenon known as total internal reflection.

Any light entering the fiber will meet the cladding at an angle greater than the critical angle. If light meets the inner surface of the cladding or the core - cladding interface at greater than or equal to critical angle then total internal reflection (TIR) occurs. So all the energy in the ray of light is reflected back into the core and none escapes into the cladding. The ray then crosses to the other side of the core and, because the fiber is more or less straight, the ray will meet

the cladding on the other side at an angle which again causes the total internal reflection. The ray is then reflected back across the core again and again until it reaches the end of the optical fiber.

### Maximum angle of incidence

The **maximum angle** of incidence in air for which all the light is total reflected at the core-cladding is given by:

$$\sin \theta = \pm \sqrt{n_1^2 - n_2^2} \quad (5.03)$$

### EXAMPLE 6.2

1. An optical fibre consists of an inner material (the fiber) with refractive index  $n_f$  and an outer material of lower refractive index  $n_c$ , known as cladding, as in Fig. 6.6 below.

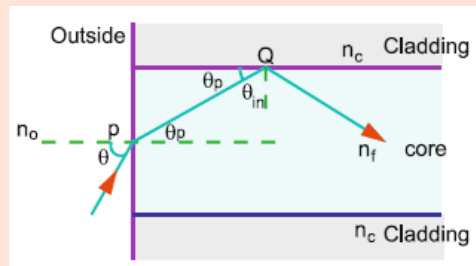

Fig.5. 6

- What is the purpose of cladding?
- Show that the maximum acceptance angle  $\theta_{\max}$  is given by  $n_o \sin \theta_{\max} = \sqrt{n_f^2 - n_c^2}$
- Discuss two main fiber loss mechanisms.

### Answer

The purpose of the cladding is to improve the transmission efficiency of the optical fibre. If cladding is not used then the signal is attenuated dramatically.

Let a ray be incident at an angle  $\theta$ , Fig.6.6, the angle of refraction at P being  $\theta_p$ . Let C be the critical angle at Q, interface of core and cladding

(in this case  $\theta_C = \theta_{\max}$  )

Refraction from air to core:  $n_o \sin \theta_{\max} = n_f \sin \theta_p \leftrightarrow \sin \theta_p = \frac{\sin \theta_{\max}}{n_f}$

$$n_0 \sin \theta_{\max} = n_f \sin \theta_p \leftrightarrow \sin \theta_p = \frac{\sin \theta_{\max}}{n_f} \quad (1)$$

Refraction from core to cladding:  $n_f \sin C = n_c \sin 90 \leftrightarrow \sin c = \frac{n_c}{n_f}$

$$n_f \sin C = n_c \sin 90 \leftrightarrow \sin c = \frac{n_c}{n_f} \quad (2)$$

Also  $\theta_p = 90 - c$  so  $\sin \theta_p = \cos c$  (3)

From (1) and (2) and using trigonometrically relation:

Simplifying  $C + \sin^2 C = \left(\frac{n_2}{n_1}\right)^2 + \left(\frac{\sin \theta}{n_1}\right)^2$

$$\theta = \sqrt{n_1^2 - n_2^2}$$

This shows that there is a maximum angle of acceptance cone outside of which entering rays will not be totally reflected within the fiber. For the largest acceptance cone, it is desirable to choose the index of refraction of the cladding to be as small as possible. This is achieved if there is no cladding at all. However, this leads to other problems associated with the loss of intensity.

- d. The transmission is reduced due to multiple reflections and the absorption of the fibre core material due to impurities.
2. A step-index fiber 0.01 cm in diameter has a core index of 1.53 and a cladding index of 1.39. See Fig.5.7. Such clad fibers are used frequently in applications involving communication, sensing, and imaging.

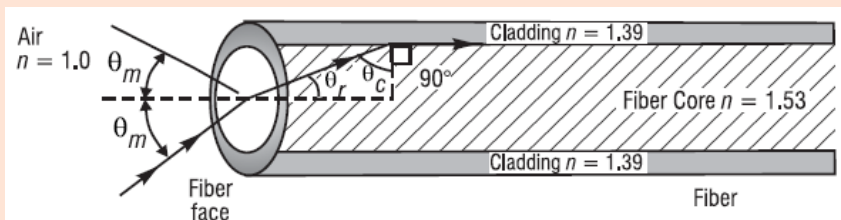

Fig.5. 7

What is the maximum acceptance angle  $\theta_m$  for a cone of light rays incident on the fiber face such that the refracted ray in the core of the fiber is incident on the cladding at the critical angle?

**Answer:**

First find the critical angle  $\theta_c$  in the core, at the core-cladding interface. Then, from geometry, identify  $\theta_r$  and use Snell's law to find  $\theta_m$ .

(1) Refraction from the core to cladding interface:  $\sin \theta_c = \frac{1.39}{1.53} \Rightarrow \theta_c = 65.3^\circ$

(2) From right-triangle geometry,  $\theta_r = 90 - 65.3 = 45.7^\circ$

(3) From Snell's law, at the fiber face,  $n_{air} \sin \theta_m = n_{core} \sin \theta_r$

And  $\sin \theta_m = \frac{n_{core}}{n_{air}} \sin \theta_r = \frac{1.53}{1.00} \sin 45.7^\circ \Rightarrow \theta_m = 39.7^\circ$

Thus, the maximum acceptance angle is  $39.7^\circ$  and the acceptance cone is twice that,  $2\theta_m = 79.4^\circ$ .

The acceptance cone indicates that any light ray incident on the fiber face within the acceptance angle will undergo total internal reflection at the core-cladding face and remain trapped in the fiber as it propagates along the fiber.

### 5.1.4 Checking my progress

1. Operation of optical fiber is based on:

- Total internal reflection
- Total internal refraction
- Snell's law
- Einstein's theory of reality
- None of the above

2. When a beam of light passes through an optical fiber

- Rays are continually reflected at the outside (cladding) of the fiber
- Some of the rays are refracted from the core to the cladding
- The bright beam coming out of the fiber is due to the high refractive index of the core
- The bright beam coming out of the fiber is due to the total internal reflection at the core-cladding interface
- All the rays of light entering the fiber are totally reflected even at very
- small angles of incidence

3. A laser is used for sending a signal along a mono mode fiber because
  - a. The light produced is faster than from any other source of light
  - b. The laser has a very narrow band of wavelengths
  - c. The core has a low refractive index to laser light
  - d. The signal is clearer if the cladding has a high refractive index
  - e. The electrical signal can be transferred quickly using a laser
  
4. Given that the refractive indices of air and water are 1 and 1,33, respectively, find the critical angle.
  
5. The frequency of a ray of light is  $6.0 \times 10^{14}$  Hz and the speed of light in air is  $3 \times 10^8$  m/s. the refractive index of the glass is 1.5.
  - a. Explain the meaning of refracting index
  - b. A ray of light has an angle of incidence of  $30^\circ$  on a block of quartz and an angle of refraction of  $20^\circ$ . What is the index of refraction of the quartz?
  
6. A beam of light passes from water into polyethylene ( $n = 1.5$ ). If  $\theta_i = 57.5^\circ$ , what is the angle of refraction?
  
7.
  - a. What is the critical angle when light is going from a diamond ( $n = 2.42$ ) to air?
  - b. Using the answer to (a), what happens when:
    - I. The angle of incidence is less than that angle?
    - II. The angle of incidence is more than that angle?

## 5.2 TYPES OF OPTICAL FIBERS

### ACTIVITY 5.2: Investigating the types of optical fiber.

Use search internet and discuss different types of optical fiber. Then, differentiate them according to their respective uses.

There are three main types of Optical Fibers: Monomode (or single mode), Multimode and **special purpose** optical fibers.

#### 5.2.1 Monomode fibers

Those are Fibers that support a single mode and are called single-mode fibers (SMF). Single-mode fibers are used for most communication links longer than 1 000 m.



*Fig.5. 8: Structure of monomode or single-mode optical fiber*

In the monomode fiber, the core is only about 8  $\mu\text{m}$  in diameter, and only the straight through transmission path is possible, i.e. one mode. This type, although difficult and expensive to make, is being used increasingly. For short distances and low bit-rates, multimode fibers are quite satisfactory. Following the emergence of single-mode fibers as a viable communication medium in 1983, they quickly became the dominant and the most widely used fiber type within Telecommunications. Major reasons for this situation are as follows:

1. They exhibit the greatest transmission bandwidths and the lowest losses of the fiber transmission media.
2. They have a superior transmission quality over other fiber types because of the absence of modal noise.
3. They offer a substantial upgrade capability (i.e. future proofing) for future wide- bandwidth services using either faster optical transmitters or receivers or advanced transmission techniques (e.g. coherent technology).
4. They are compatible with the developing integrated optics technology.
5. The above reasons 1 to 4 provide confidence that the installation of single-mode fiber will provide a transmission medium which will have adequate performance such that it will not require replacement over its anticipated lifetime of more than 20 years. (John, 2009)

### **5.2.2 Multimode fibers**

In multimode fiber, light travels through the fiber following different light paths called “**modes**” as indicated on Fig.5.9. Those are fibers that support many propagation paths. A multi-mode optical fiber has a larger core of about 50  $\mu\text{m}$ , allowing less precise, cheaper transmitters and receivers to connect to it as well as cheaper connectors.

### **5.2.2 Multimode fibers**

In multimode fiber, light travels through the fiber following different light paths called “**modes**” as indicated on Fig.5.9. Those are fibers that support many propagation paths. A multi-mode optical fiber has a larger core of about 50  $\mu\text{m}$ , allowing less precise, cheaper transmitters and receivers to connect to it as well as cheaper connectors

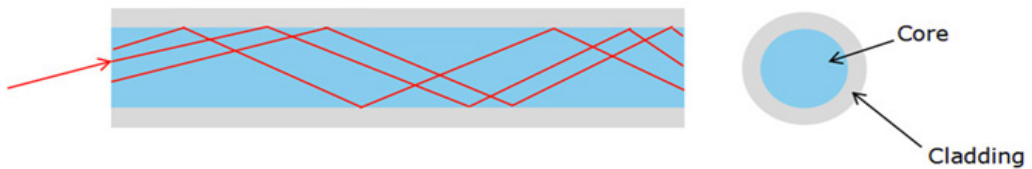

Fig.5. 9 Multimode optical fiber

The propagation of light through a multimode optical fiber is shown on Fig. 5.9. However, a multi-mode fiber introduces multimode distortion, which often limits the bandwidth and length of the link. Furthermore, because of its higher dopant content, multi-mode fibers are usually expensive and exhibit higher attenuation.

There are two types of multi-mode optical fibers: multimode step-index and multimode graded index (see Fig.5.10)

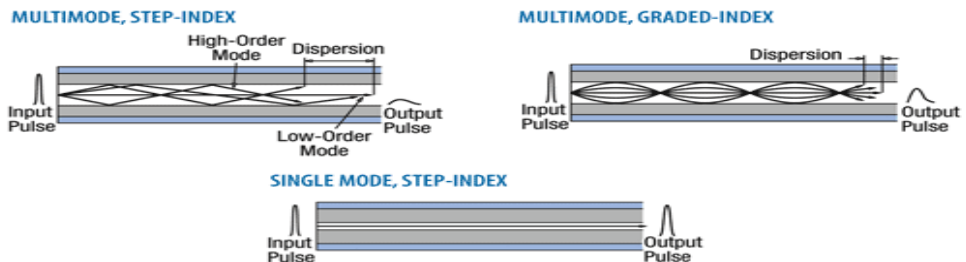

Fig.5. 10: Step index and graded index multimode optical fibers illustration.

- In **step-index multimode type**, the core has the relatively large diameter of  $50\mu\text{m}$  and the refractive index changes suddenly at the cladding. The wide core allows the infrared to travel by several paths or modes. Paths that cross the core more often are longer, and signals in those modes take longer to travel along the fiber. Arrival times at the receiver are therefore different for radiation of the same pulse,  $30\text{ns km}^{-1}$ , being a typical difference. The pulse is said to suffer **dispersion**, it means that it is spread out.
- In the **graded index multimode type**, the refractive index of the glass varies continuously from a higher value at the center of the fiber to a low value at the outside, so making the boundary between core and the cladding indistinct. Radiation following a longer path, travel faster on average, since the speed of light is inversely proportional to the refractive index. The arrival times for different modes are the about the same (to within  $1\text{ns km}^{-1}$ ) and all arrive more or less together at the receiving end. Dispersion is thereby much reduced.

### 5.2.3 Special-purpose optical fiber

Some special-purpose optical fiber is constructed with a non-cylindrical core and/or cladding layer, usually with an elliptical or rectangular cross-section. These include: polarization-maintaining fiber and fiber designed to suppress whispering **gallery mode propagation**.

- **Polarization-maintaining** fiber is a unique type of fiber that is commonly used in fiber optic sensors due to its ability to maintain the polarization of the light inserted into it.
- **Photonic-crystal fiber** is made with a regular pattern of index variation. It is often in the form of cylindrical holes that run along the length of the fiber. Such fiber uses diffraction effects in addition to total internal reflection, to confine light to the fiber's core.

### 5.2.4 Checking my progress

1. Fiber optics is best known for its application in long-distance telecommunications.
  - a. True
  - b. False
2. Choose the basic types of optical fiber:

a. Single-mode	e. Multi-mode
b. X-mode	f. A and C
c. Microwave-mode	g. B and D
d. Graded-index mode	h. A and E
3. Single-mode fiber has the advantage of greater bandwidth capability. It has the disadvantage of:
  - a. Being harder to bend
  - b. Smaller mechanical tolerances in connectors and splices
  - c. Being difficult to couple light into
  - d. B and C
  - e. None of the above
4. Describe with the aid of simple ray diagrams:
  - a. The multimode step index fiber;
  - b. The single-mode step index fiber.
  - c. Compare the advantages and disadvantages of these two types of fiber for use as an optical channel.

## 5.3 Mechanism of attenuation

### ACTIVITY 5.3: Light transmission analysis in optical fiber

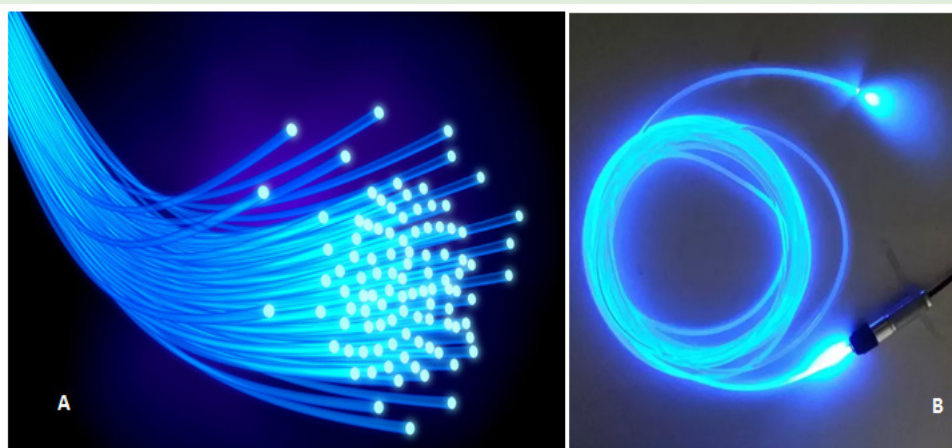

*Fig.5. 11 The images to show the attenuation in optical fiber*

Observe the image clearly, and answer to the following questions:

1. Does all the light from the source getting to the destination?
2. What do you think is causing the loss in light transmission?
3. What can be done to minimize that loss in the optical fibers above?

Attenuation in fiber optics, also known as transmission loss, is the reduction in intensity of the light beam (or signal) as it travels through the transmission medium. Over a set distance, fiber optic with a lower attenuation will allow more power to reach its receiver than a fiber with higher attenuation.

**Attenuation can be caused by several factors both extrinsic and intrinsic:**

- **Intrinsic attenuation** is due to something inherent to the fiber such as impurities in the glass during manufacturing. The interaction of such impurities with light results in the scattering of light or its absorption.
- **Extrinsic attenuation** can be caused by macro bending and microlensing. A bent imposed on an optical fiber produce a strain in that region of the fiber and affects its refractive index and the critical angle of the light ray in that area. Macrobending that is a large-scale bent and microbending which is a small-scale bent and very localized are external causes that result in the reduction of optical power.

Attenuation coefficients in fiber optics usually are expressed decibels per kilometer (dB/km) through the medium due to the relatively high quality of transparency of modern optical transmission media. It is observed that the

attenuation is a function of the wavelength of the light. The attenuation  $\alpha_{tot}(\lambda)$  at wavelength  $\lambda$  of a fiber between two cross-sections, 1 and 2, separated by distance  $L$  is defined, as

$$\alpha_{tot}(\lambda) = \frac{10}{L} \text{Log} \frac{P_1(\lambda)}{P_2(\lambda)} \quad (5.04)$$

where  $P_1(\lambda)$  optical power at the cross-section 1, and  $P_2(\lambda)$  the optical power at the cross-section 2. Attenuation is an important limiting factor in the transmission of a digital signal across large distances. Thus, much research has gone into both limiting the attenuation and maximizing the amplification of the optical signal.

### 5.3.1 Light scattering and absorption

In the light transmission of signals through optical fibers, attenuation occurs due to light scattering and absorption of specific wavelengths, in a manner similar to that responsible for the appearance of color.

#### a. Light scattering

*Scattering losses*

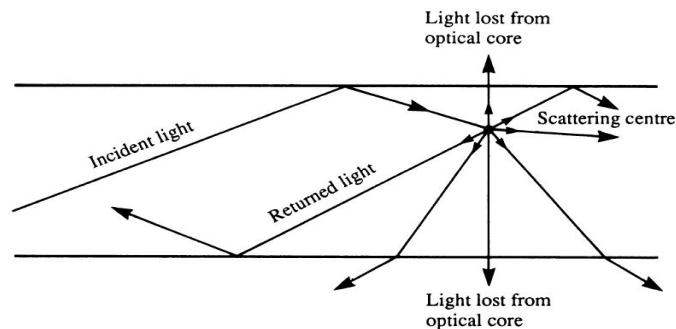

Fig.5. 12: Light scattering in optical fiber.

The propagation of light through the core of an optical fiber is based on total internal reflection of the light wave. Rough and irregular surfaces, even at the molecular level, can cause light rays to be reflected in random directions as it is illustrated on Fig.5.12. This is called diffuse reflection or scattering, and it is typically characterized by wide variety of reflection angles.

Light scattering depends on the wavelength of the light being scattered. Thus, limits to spatial scales of visibility arise, depending on the frequency of the incident light-wave and the physical dimension (or spatial scale) of the scattering center, which is typically in the form of some specific micro-structural

feature. Since visible light has a wavelength of the order of one micrometer (one millionth of a meter) scattering centers will have dimensions on a similar spatial scale. Thus, attenuation results from the incoherent scattering of light at internal surfaces and interfaces.

### **b. Light absorption**

Material absorption is a loss mechanism related to the material composition and fiber fabrication process. This results in the dissipation of some transmitted optical power as heat in the waveguide. Absorption is classified into two basic categories: Intrinsic and extrinsic absorptions. (John, 2009)

Intrinsic absorption: is caused by basic fiber material properties. If an optical fiber is absolutely pure, with no imperfections or impurities, then all absorption will be intrinsic. Intrinsic absorption in the ultraviolet region is caused by bands. Intrinsic absorption occurs when a light particle (photon) interacts with an electron and excites it to a higher energy level.

### **5.3.2 Measures to avoid Attenuation**

The transmission distance of a fiber-optic communication system has traditionally been limited by fiber attenuation and by fiber distortion.

- **Repeaters:** Repeaters convert the signal into an electrical signal, and then use a transmitter to send the signal again at a higher intensity than was received, thus counteracting the loss incurred in the previous segment. They are mostly used to be installed about once every 20 km.
- **Regenerators:** Optical fibers link, in common with any line communication system, have a requirement for both jointing and termination of the transmission medium. When a communications link must span a larger distance than existing fiber-optic technology is capable of, the signal must be *regenerated* at intermediate points in the link by optical communications repeaters called regenerators. An optical regenerator consists of optical fibers with special coating (doping). The doped portion is pumped with a **laser**. When the degraded signal comes into the doped coating, the energy from the laser allows the doped molecules to become lasers themselves. The doped molecules then emit a new strong light signal with the same characteristics as the incoming weak signal. Basically, the regenerator is a laser amplifier for the incoming signal.
- **Optical Amplifiers:** Another approach is to use an optical amplifier which amplifies the optical signal directly without having to convert the signal into the electrical domain. It is made by doping a

length of fiber with the rare-earth mineral erbium and pumping it with light from a laser with a shorter wavelength than the communications signal (typically 980 nm). Amplifiers have largely replaced repeaters in new installations.

### 5.3.3 Checking my progress

1. True or False: One of the reasons fiber optics hasn't been used in more areas has been the improvement in copper cable such as twisted pair.
2. True or False: With current long-distance fiber optic systems using wavelength-division multiplexing, the use of fiber amplifiers has become almost mandatory.
3. Fiber optics has extraordinary opportunities for future applications because of its immense bandwidth.
  - a. True
  - b. False
4.
  - a. What do we mean by attenuation in optical fibers?
  - c. State two ways in which energy is lost in optical fibers.
  - d. If a fiber loses 5% of its signal strength per kilometer, how much of its strength would be left after 20 km?

## 5.4 OPTICAL TRANSMITTER AND OPTICAL RECEIVER

### ACTIVITY 5.4: Investigating the signal sources and signal receiver for optic fibers

1. With the basic information you know about the functioning process of optical fiber, answer to the following questions.
2. Where does the light that is transmitted into the optical fiber core medium come from?
3. What are the type compositions of the light signal propagating into optical fiber?
4. Discuss and explain the function principle of signal generators and signal receivers of light from optical fibers.

The process of communicating using fiber-optics involves the following basic steps:

1. Creating the optical signal involving the use of a transmitter, usually from an electrical signal.
2. Relaying the signal along the fiber, ensuring that the signal does not become too distorted or weak.

3. Receiving the optical signal.
4. Converting it into an electrical signal

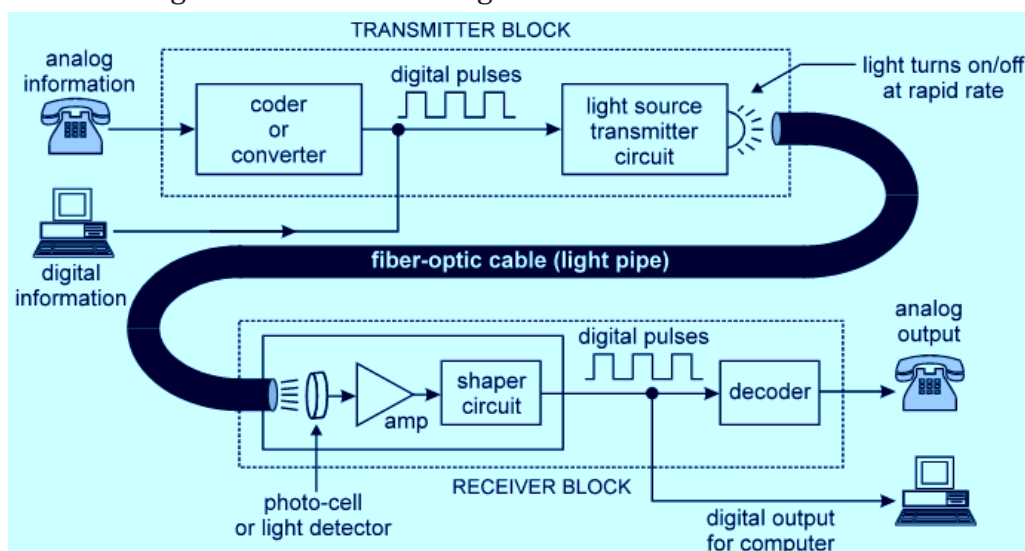

Fig.5. 13: Optical fiber communication mechanism (Transmitter and receiver blocks).

### 5.4.1 Transmitters

The most commonly used optical transmitters are semiconductor devices such as light-emitting diodes (LEDs) and laser diodes. The difference between LEDs and laser diodes is that LEDs produce incoherent light, while laser diodes produce coherent light. For use in optical communications, semiconductor optical transmitters must be designed to be compact, efficient and reliable, while operating in an optimal wavelength range and directly modulated at high frequencies (see Fig.5.13: Transmitter block).

In its simplest form, a LED is a forward-biased p-n junction, emitting light through spontaneous emission, a phenomenon referred to as electroluminescence. The emitted light is incoherent with a relatively wide spectral width of 30–60 nm. LED light transmission is also inefficient, with only about 1% of input power, or about 100 microwatts, eventually converted into launched power which has been coupled into the optical fiber. However, due to their relatively simple design, LEDs are very useful for low cost applications.

### 5.4.2 The Optical Receivers

The main component of an optical receiver is a photodetector (photodiode) which converts the infrared light signals into the corresponding electrical signals by using photoelectric effect before they are processed by the decoder for conversion back into information. The primary photo detectors for telecommunications are made from Indium gallium arsenide (see Fig.5.13).

The photodetector is typically a semiconductor-based photodiode. Several types of photodiodes include p-n photodiodes, p-i-n photodiodes, and avalanche photodiodes. Metal-semiconductor-metal (MSM) photodetectors are also used due to their suitability for circuit integration in regenerators and wavelength-division multiplexers.

### 5.4.3 Checking my progress

1. Circle the three basic components in a fiber optic communications system.

- a. Telescope
- b. Transmitter
- c. Receiver
- d. Surveillance satellites
- e. Maser fiber
- f. Optical fiber
- G. Alternator

2. Information (data) is transmitted over optical fiber by means of:

- a. Light
- b. Radio waves
- c. Cosmic rays
- d. Acoustic waves
- e. None of the above

3. Connectors and splices add light loss to a system or link.

- a. True
- b. False

4. Do fibers have losses?

## 5.5. USES OF OPTICAL FIBERS

### ACTIVITY 6.5: Applications of fiber optics in telecommunication and in medicine

Use the internet or the library to investigate the applications of optical fiber in medicine and telecommunication systems.

#### 5.5.1. Telecommunications Industry

Optical fibers offer huge communication capacity. A single fiber can carry the conversations of every man, woman and child on the face of this planet, at the same time, twice over. The latest generations of optical transmission systems are beginning to exploit a significant part of this huge capacity, to satisfy the rapidly growing demand for data communications and the Internet.

The main advantages of using optical fibers in the communications industry are:

1. A much greater amount of information can be carried on an optical fiber compared to a copper cable.

2. In all cables some of the energy is lost as the signal goes along the cable. The signal then needs to be boosted using regenerators. For copper cable systems these are required every 2 to 3km but with optical fiber systems they are only needed every 50km.
3. Unlike copper cables, optical fibers do not experience any electrical interference. Neither will they cause sparks so they can be used in explosive environments such as oil refineries or gas pumping stations.
4. For equal capacity, optical fibers are cheaper and thinner than copper cables and that makes them easier to install and maintain.

### 5.5.2 Medicine Industry

The advent of practicable optical fibers has seen the development of much medical technology. Optical fibers have paved the way for a whole new field of surgery, called laproscopic surgery (or more commonly, keyhole surgery), which is usually used for operations in the stomach area such as appendectomies. Keyhole surgery usually makes use of two or three bundles of optical fibers. A “bundle” can contain thousands of individual fibers”. The surgeon makes a number of small incisions in the target area and the area can then be filled with air to provide more room.

One bundle of optical fibers can be used to illuminate the chosen area, and another bundle can be used to bring information back to the surgeon. Moreover, this can be coupled with laser surgery, by using an optical fiber to carry the laser beam to the relevant spot, which would then be able to be used to cut the tissue or affect it in some other way.

### 5.5.3 Checking my progress

The basic unit of digital modulation is:

- |         |                      |
|---------|----------------------|
| a. Zero | c. A and B           |
| b. One  | d. None of the above |

## 5.6 ADVANTAGES AND DISADVANTAGES OF OPTICAL FIBERS

### ACTIVITY 5.6: Advantages and disadvantages of optical fibers

Use search internet or your library to investigate the advantages and disadvantages of fiber optics.

Although there are many benefits to using optical fibers, there are also some disadvantages. Both are discussed below: fiber in medicine and telecommunication systems.

### 5.6.1 Advantages

- **Capacity:** Optical fibers carry signals with much less energy loss than copper cable and with a much higher bandwidth. This means that fibers can carry more channels of information over longer distances and with fewer repeaters required.
- **Size and weight:** Optical fiber cables are much lighter and thinner than copper cables with the same bandwidth. This means that much less space is required in underground cabling ducts. Also they are easier for installation engineers to handle.
- **Security:** Optical fibers are much more difficult to tap information from undetected; a great advantage for banks and security installations. They are immune to electromagnetic interference from radio signals, car ignition systems, lightning etc. They can be routed safely through explosive or flammable atmospheres, for example, in the petrochemical industries or munitions sites, without any risk of ignition.
- **Running costs:** The main consideration in choosing fiber when installing domestic cable TV networks is the electric bill. Although copper coaxial cable can handle the bandwidth requirement over the short distances of a housing scheme, a copper system consumes far more electrical power than fiber, simply to carry the signals.

### 5.6.2 Disadvantages

- **Price:** In spite of the fact that the raw material for making optical fibers, sand, is abundant and cheap, optical fibers are still more expensive per metre than copper. Having said this, one fiber can carry many more signals than a single copper cable and the large transmission distances mean that fewer expensive repeaters are required.
- **Special skills:** Optical fibers cannot be joined together (spliced) as easily as copper cable and requires additional training of personnel and expensive precision splicing and measurement equipment.

### 5.6.3 Checking my progress

1. List two advantages of using optical fiber. \_\_\_\_\_
2. The replacement of copper wiring harnesses with fiber optic cabling will increase the weight of an aircraft.
  - a. True
  - b. False

## END UNIT ASSESSMENT 5

1. a. An endoscope uses coherent and non-coherent fiber bundle
  - I. State the use of the coherent bundle and describe its arrangement of fibers.
  - II. State the use of the non-coherent bundle and describe its arrangement of fibers.
- b. Each fiber has a core surrounded by cladding. Calculate the critical angle at the core-cladding interface.

Refractive index of core = 1.52

Refractive index of cladding = 1.

2. (a) Fig.5.9 shows a ray of light travelling through an individual fiber consisting of cladding and a core. One part has a refractive index of 1.485 and the other has a refractive index of 1.511.

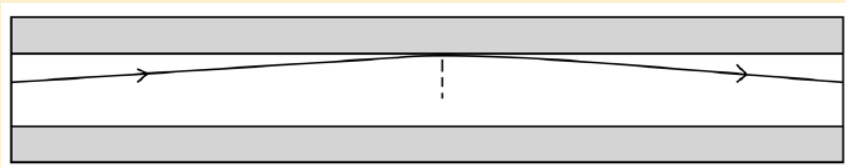
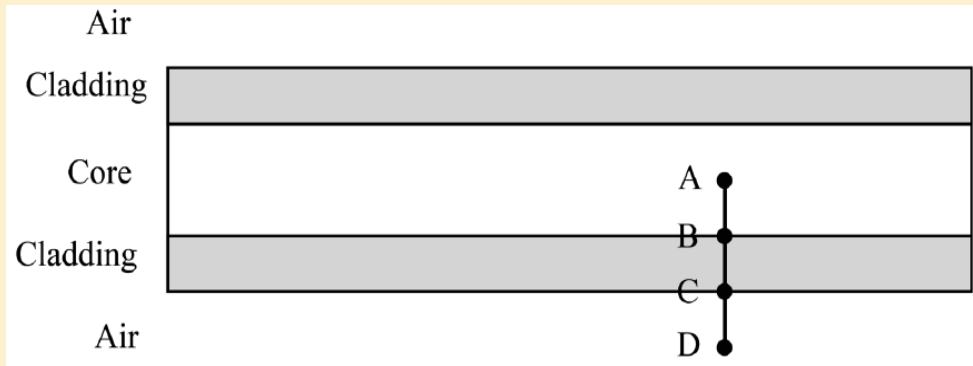

Fig.5. 9: Light transmission in optical fiber.

- I. State which part of the fiber has the higher refractive index and explain why.
  - II. (ii) Calculate the critical angle for this fiber.
- (b) The figure below shows the cross-section through a clad optical fiber which has a core of refractive index 1.50.



Complete the graph below to show how the refractive index changes with the radial distance along the line ABCD in the figure above.

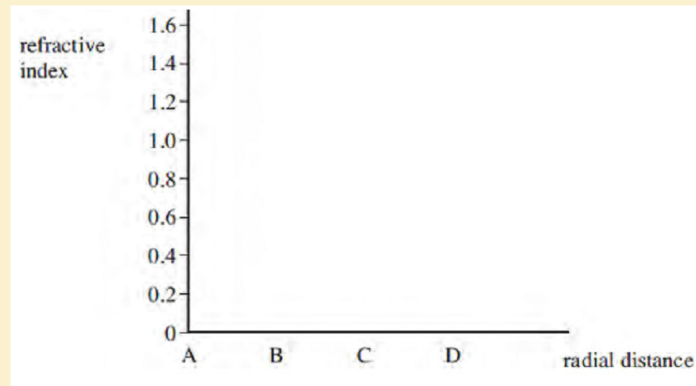

Fig.5. 11: Axes for the half life decay curve

3.
  - a. What do we mean by attenuation in optical fibers?
  - b. State two ways in which energy is lost along the length of an optical fiber.
  - c. If a fiber loses 5% signal strength per km, how much strength would be left after 20 km?
  
4. Estimate the length of time it would take a fiber optic system to carry a signal from the UK to the USA under the Atlantic. (Take  $c = 2 \times 10^8$  m/s in the cable. Estimate the length of the cable under the sea.
  - a. Estimate the length of time it would take a microwave signal to travel from the UK to the USA a satellite link. (Geosynchronous satellites orbit at a height of about 36 000 km above the Earth's surface.
  - b. Which would give less delay in a telephone conversation?

# UNIT 6

## BLOCK DIAGRAM OF TELECOMMUNICATION



**Key unit competence:** Construct and analyze block diagram of telecommunication systems.

### My goals

- Identify parts of a block diagram of telecommunication system.
- Differentiate oscillator, modulator and amplifier.
- Outline the function of a microphone and antenna.
- Describe terms applied in telecommunication systems
- Construct, analyse and judge block diagrams of a telecommunication system.
- Realise that parts of a telecommunication system are dependent

## INTRODUCTORY ACTIVITY

### Investigating the function of wireless microphone

#### Materials:

- Wireless microphone set
- Amplifier and mixer
- Connecting wires
- Speaker

#### Procedure:

Connect the full sound system such that the signal will be transmitted to the speakers using wireless microphone.

#### Questions:

1. How is your voice getting to the speakers?
2. Where else this system is used?
3. What are advantages and disadvantages of communication?

## 6.1. OPERATING PRINCIPLE OF MICROPHONE

### ACTIVITY 6.1: Investigating the function of a microphone

Take the case of two people talking on telephone (see Fig.6.1). Observe the image below and answer to the following questions:



*Fig.6.1 People talking on telephone*

1. Discuss the functioning process of a telephone.
2. Differentiate the functions of a microphone from that of a speaker.

**Telecommunication** in real life is the **transmission** of signals and other types of data of any nature by wire, radio, optical or other electromagnetic systems of communication. Telecommunication occurs when the exchange of information between communicating participants includes the use of signs or other technologically based materials such as telephone, TV set, radio receiver, radio emitter, computer, and so on. All can be done either mechanically, electrically or electronically.

The use of microphones began with the telephone in the nineteenth century. The requirements were basically those of speech intelligibility, and the carbon microphone, developed early in that art, is still used in telephones today. Particles of carbon are alternately compressed and relaxed by the diaphragm under the influence of sound pressure, and the resulting alternation of resistance modulates the current proportionally to the change in resistance. Carbon microphones are noisy; they have limited dynamic range and produce high levels of distortion. However, none of these defects is really serious in its application to telephony.

### Operating principle of microphones

A microphone converts sound vibrations into electrical entity. Basically a microphone has a diaphragm which moves when sound pressure pushes it. This movement can be converted into proportional voltage using several possible transducers.

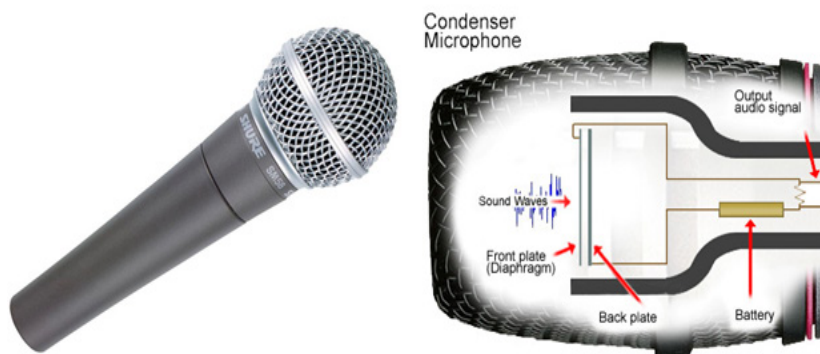

*Fig.6. 2: The outer and internal view of a microphone*

**A transducer** is a device which receives electrical, mechanical or acoustic waves from one medium and converts them into related waves for a similar or different medium. Thus, it can be said that a microphone is a transducer that converts acoustical sound energy into electrical energy. Its basic function is therefore to convert **sound energy** into **electrical audio signals** which can be used for further processing. Microphones are classified based on **construction** and **directivity**.

## 6.2 CHANNELS OF SIGNAL TRANSMISSION

### ACTIVITY 6.2: Investigating signal transmission

Basing on the activity 6.1, explain and discuss how the voices are transmitted from our mouth to telephone and then to the receiver's telephone

An audio frequency (acronym: AF) or audible frequency is characterized as a periodic vibration whose frequency is audible to the average human. The SI unit of frequency is the hertz (Hz). It is the property of sound that most determines pitch. The generally accepted standard range of audible frequencies is 20 Hz to 20 kHz, although the range of frequencies that individuals hear is greatly influenced by environmental factors. Frequencies below 20 Hz are generally felt rather than heard, assuming the amplitude of the vibration is great enough. Frequencies above 20 kHz can sometimes be sensed by young people. High frequencies are the first to be affected by hearing loss due to age and/or prolonged exposure to very loud noises.

**Modulation** is the process of superimpose to a low frequency signal (original signal) a high frequency signal (carrier signal) for transmission. The resulting signal is a modulated or radio signal.

#### 6.2.1 Amplitude modulation (AM)

It is a type of modulation, where the amplitude of the carrier wave is changed in accordance with the intensity of the signal. However, the frequency and the phase shift of the modulated wave remains the same.

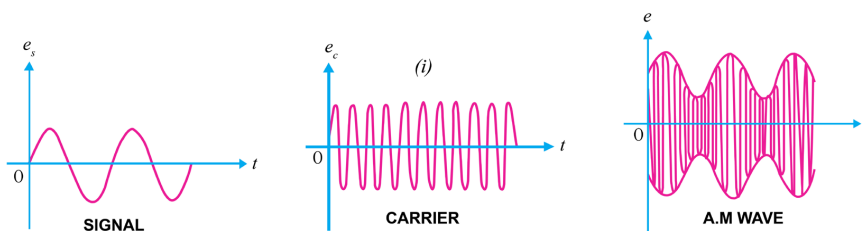

Fig.6.3 A graphs of amplitude modulation

Note that the amplitudes of both positive and negative half-cycles of carrier wave are changed in accordance with the signal. For instance, when the signal is increasing in the positive sense, the amplitude of carrier wave also increases. On the other hand, during negative half-cycle of the signal, the amplitude of carrier wave decreases. Amplitude modulation is done by an electronic circuit called **modulator**.

## 6.2.2 Frequency modulation (FM).

It is a type of modulation, where the frequency of the carrier wave is changed in accordance with the intensity of signal. The amplitude and the phase shift of the modulated wave remain the same. The frequency variations of carrier wave depend upon the instantaneous amplitude of the original signals. The carrier frequency increases and decreases respectively to its positive and negative peak values as the voltage of the original signal seem to approach its peak values.

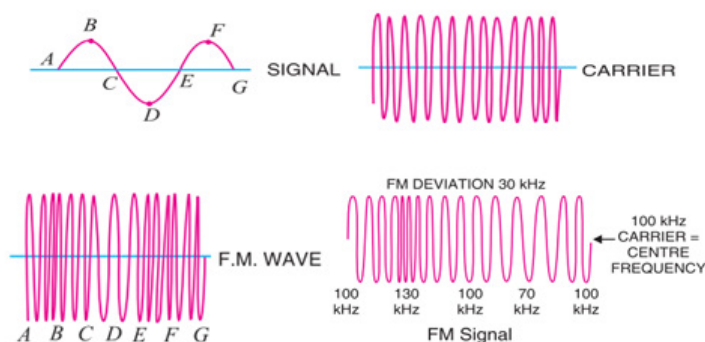

Fig.6. 4: Process of FM transmission

### Comparison of amplitude modulation and frequency modulation

FM	AM
The amplitude and phase shift of carrier wave remains constant with modulation	The amplitude of carrier changes with modulation
The carrier frequency changes with modulation	The carrier frequency and phase shift of carrier wave remains constant with modulation
The carrier frequency changes according to the strength of the modulating signal	The carrier amplitude changes according to the strength of the modulating signal

Table 6. 1: Comparison between FM and AM

## 6.2.3 Short wave (SW)

A short wave is any wave whose frequency ranges between **300 kHz** and **3 MHz**. In transmission, these waves are used for very long distance communication as their bands can be reflected or refracted from the ionosphere by an electrically charged layer with atoms in the atmosphere.

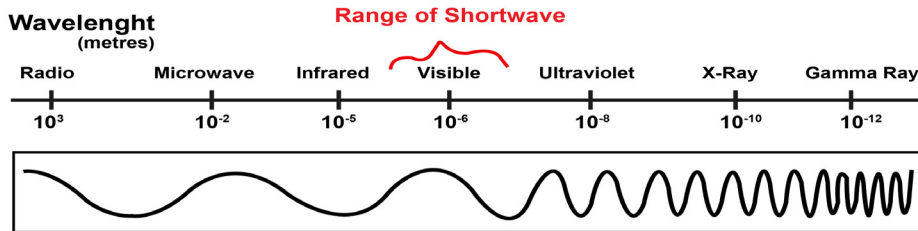
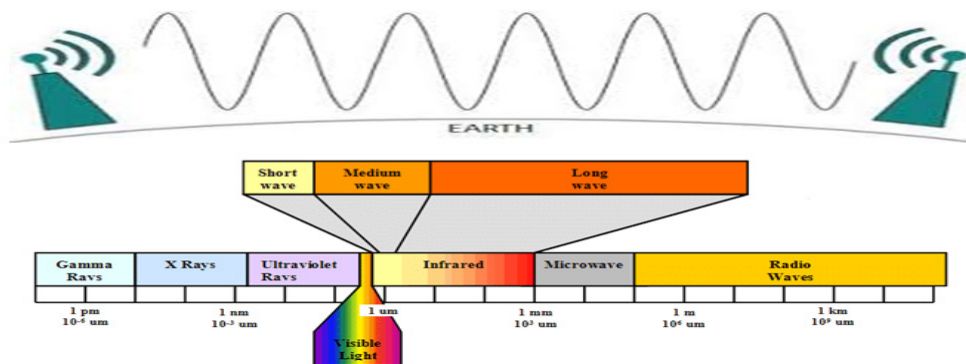

Fig.6. 5: Short wave illustration

The short waves directed at an angle into the sky can be reflected back to Earth at great distances, beyond the horizon. This called **sky wave** or **skip propagation**. These waves are used for radio broadcasting of voice and music to shortwave listeners over very large areas; sometimes entire continents or beyond. They are also used for military communication, diplomatic communication, and two-way international communication by amateur radios enthusiasts for hobby.

### 6.2.4 Medium wave (MW)

**Medium wave** (MW) is the part of the **medium** frequency (MF) radio band used mainly for AM radio broadcasting. It is the original radio broadcasting band, in use since the early 1920's. It is typically used by stations serving a local or regional audience. At night, medium wave signals are no longer absorbed by the lower levels of the ionosphere, and can often be heard hundreds or even thousands of miles away.



For Europe the MW band ranges from 526.5 kHz to 1606.5 kHz, using channels spaced every 9 kHz, and in North America an extended MW broadcast band ranges from 525 kHz to 1705 kHz, using 10 kHz spaced channels.

## 6.2.5 Checking my progress

1. In transmission, the range of short waves are between
  - a. Radio wave and microwave
  - b. X-rays and gamma rays
  - c. Infrared and visible light
  - d. Infrared and ultraviolet
2. Where Short waves can be used?
3. Explain what is meant by Medium wave (MW)
4. Distinguish between Amplitude modulation and frequency modulation

## 6.3 CARRIER WAVE AND MODULATOR

### 6.3.1 Concept of carrier wave modulation

#### ACTIVITY 6.3: Modulation techniques

What are applications of such a system shown in the below figure?

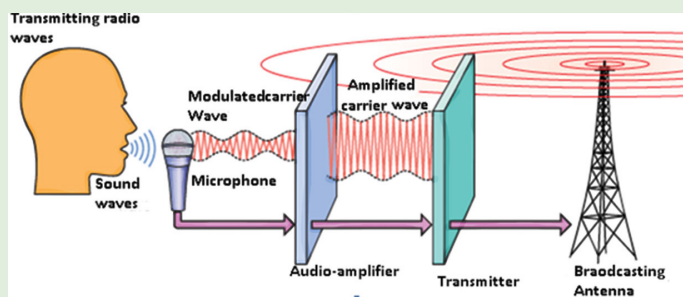

Fig.6. 6: Radio wave transmission

Observe the mechanism above (Fig.6.6) and answer to the following questions

1. Analyze the provided figure and explain the transmission process used there.
2. What are applications of such a system shown in the above figure?

**Modulation** is the process of varying the characteristics of carrier signal with the modulating signal or **modulation** is defined as the superimposition of low frequency baseband signal (modulating signal) over high frequency carrier signal by varying different parameters of the carrier signals (see Fig.6.6). Based on the types of parameters that are varied in proportion to the baseband (low frequency) signal, modulation is of different types. In digital modulation, the message signal is converted from analog into digital. In digital modulation techniques, the analog carrier signal is modulated by discrete signal. The carrier wave is switched on and off to create pulses such that signal is modulated.

Low frequency signal (Baseband) communication is not commonly used for distance communication. Low frequency baseband signals, having low energy, if transmitted directly will get distorted. So baseband signal must be modulated with high frequency signal to increase the range of transmission.

### 6.3.2 Checking my progress

1. In.....transmission, the carrier signal modulated so that its amplitude varies with the changing amplitudes of the modulating signal
  - a. AM
  - b. PM
  - c. FM
  - d. None of the above?
2. Distinguish between analog signal and digital signal?
3. What is meant by carrier wave in telecommunication?
4. What is the application of a carrier wave in a telecommunication system?

## 6.4 OSCILLATOR, RADIO FREQUENCY AMPLIFIER AND POWER AMPLIFIER

### ACTIVITY 6.4: Investigating what is an oscillator and a radio frequency amplifier

Make an intensive research on the properties and function of an oscillator and radio frequency amplifier. According to your findings, answer to the following questions:

1. Explain a radio frequency amplifier and state its importance in telecommunication?
2. What do you understand by an oscillator in telecommunication system? Discuss its importance?
3. Describe other uses of oscillator and radio frequency amplifier.

### 6.4.1 Oscillator

**Oscillators** are electronic circuits that produce a periodic waveform on its output **with only the DC supply voltage as an input**. The output voltage can be either sinusoidal or non-sinusoidal, depending on the type of oscillator; thus, the outputs signals can be sine waves, square waves, triangular waves, and saw tooth waves.

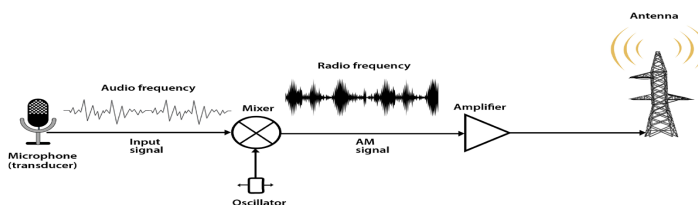

Fig.6.7: Basic function of oscillator and radio frequency amplifier in telecommunication system

**The oscillation in any circuit will depend on the following properties:**

- Amplification of the used amplifier
- A frequency determining device (receiver/ transmitter)
- Signal regeneration (Positive feedback)

**Factors which may fluctuate the operating frequency**

- Long time of operation
- Heat that is generated along the operation
- Operating point of the active elements
- Frequency dropper elements (capacitors, inductors)
- Change in total opposition faced by the alternating current (impedance)

**Oscillators may be classified in three ways, including:**

- a. The design principle used where we have a positive and a negative feedback oscillators,
- b. The frequency range of the signal over which they are used:
  - Audio Frequency (AF) oscillators (frequency range is 20 Hz to 20 kHz)
  - Radio Frequency (RF) oscillators (frequency range is 20 kHz to 30 MHz)
  - Video Frequency oscillators (frequency range is dc to 5 MHz)
  - High Frequency (HF) oscillators (frequency range is 1.5 MHz to 30 MHz)
  - Very High Frequency (VHF) oscillators (frequency range is 30 MHz to 300 MHz)
- c. The nature of generated signals where we have:
  - Sinusoidal Oscillators: These are known as harmonic oscillators and are generally LC tuned-feedback or RC tuned-feedback type oscillator that generates a sinusoidal waveform which is of constant amplitude and frequency.
  - Non-sinusoidal Oscillators: These are known as relaxation oscillators and generate complex non-sinusoidal waveforms that changes very quickly from one condition of stability to another such as square-wave, triangular-wave or sawtooth-wave type waveforms.

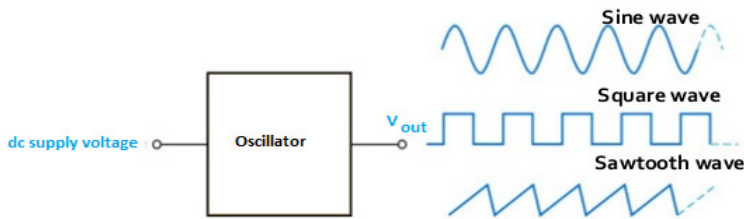

Fig.6. 8: Types of signals output of an oscillator

The oscillators have a variety of applications. In some applications we need voltages of low frequencies, in others of very high frequencies. For example to test the performance of a stereo amplifier, we need a signal of variable frequency in the audio range (20 Hz-20 KHz). Next to amplifiers, oscillators are the most important analog circuit block. Oscillators can be found in almost every imaginable electronic system. For example all radio receiving systems must have a local oscillator. All transmitting systems require oscillators to define the carrier frequency. Similarly, most digital systems are clocked and require a master clock oscillator to operate. Signal sources, which are essential for testing electronic systems, are also precise oscillators whose frequency and amplitude can be accurately set according to the requirement.

### 6.4.2 Radio frequency amplifier

**An amplifier** is an electronic device which can increase the amplitude or the power of the input signal to its input parts, without the needs of modifying the form of that signal. Mostly, these devices are used in telecommunication, especially in receivers. Any amplifier has an active element, more often transistors, though there may exist also resistors, inductors and capacitors.

#### Classes of amplifiers

There exist two classes: **Capacitor coupled amplifiers** and **transformer coupled amplifiers**. The two are used in multistage amplifiers, that is when we connect two stage amplifiers using a capacitor and when we connect two stages amplifiers using a transformer, we get a capacitor coupled amplifier and a transformer coupled amplifier respectively.

#### Characteristics of RF amplifier

1. It may require or not a wide bandwidth signal to amplify
2. The output signal from the RF amplifier may or not be linear
3. They require to operate at a narrow bandwidth
4. They can use filters to reduce bandwidth

5. To tune the circuit, the resonant frequency is set to  $f_0 = \frac{1}{2\pi\sqrt{LC}}$

All electronic devices have an inductive reactance and capacitive reactances. The latter are vary as the frequency fluctuates. Normally, as the frequency increases, the inductive reactance increases but capacitive reactance decreases. Then the circuit will be called **self-resonate** at point, where the two characteristics mentioned above become equal.

In signal processing, we need to realize as many operations as possible so that we arrive to a signal that fits the transmission standards. The signal to be modulated is referred to as a **baseband** signal. The carriersignal needs to be a higher frequency than the baseband. A RF amplifier is a device which amplifies the baseband signal. However, devices such as Oscillators, Mixers, Multipliers and frequency synthesizers can be used to meet the above conditions.

### 6.4.3 Power Amplifier

Signals are amplified in several stages (Fig.6.9). The initial stages are small signal amplifiers, they are designed to give good voltage gain, so they are called **voltage amplifiers**. At the final stage, the signal becomes large, the large-signal amplifier is called **power amplifier**, as it is designed for good power gain.

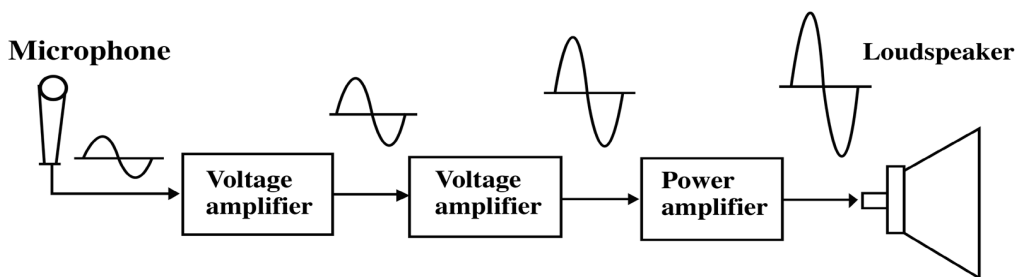

Fig.6. 9 The functioning mechanism of power amplifier

The Fig.6.10 shows that the power amplifiers are classified according to the **conduction angle** they produced. *Conduction angle* measures the portion of the input cycle that is reproduced at the output of a power amplifier. If the conduction angle is  $360^\circ$ , which means that all of the input cycle is reproduced, the amplifier is called **class A amplifier**.

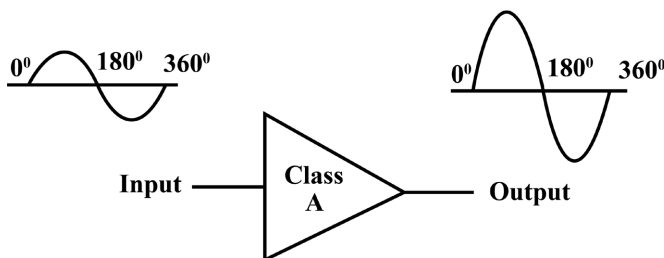
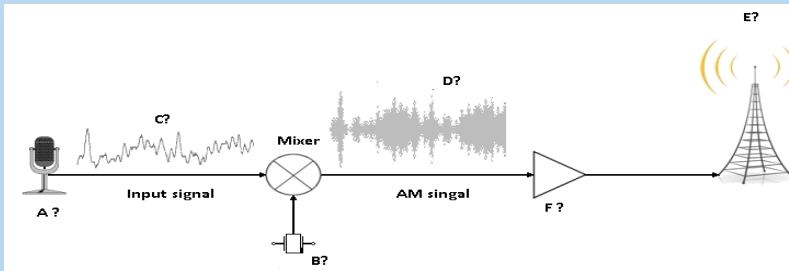

Fig.6. 10: The conduction angle of power amplifier

Every amplifier has a DC equivalent circuit and an AC equivalent circuit. Because of this, it has two load lines : a Dc load line and an AC load line.

### 6.4.4 Checking my progress

1. State the classifications of oscillators according to Frequency Band of the Signals
2. Explain what is mean by Oscillator
3. The figure is about transmission of signals in telecommunication. Study it carefully and label it.



## 6.5 ANTENNAS

### ACTIVITY 6.5: Defining types of antennas

Observe clearly the images on the fig. 6.11 below and answer the questions that follow:

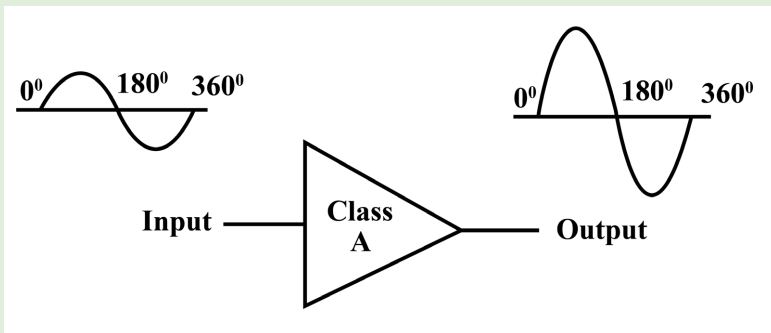

Fig.7.11 Different types of antenna

1. Describe the different the types of antenna shown in the Fig.7.11 above.
2. Discuss other different types of antenna you know.
3. Discuss and explain the function principle of an antenna.

**An antenna or aerial** is an electrical device connected (often through a transmission line) to the receiver or transmitter which converts electric power

into radio waves, and vice versa. It is usually used with a radio transmitter or radio receiver. In transmission, a radio transmitter supplies an oscillating radio frequency electric current to the antenna's terminals, and the antenna radiates the energy from the current as electromagnetic waves (radio waves). In reception, an antenna intercepts some of the power of an electromagnetic wave in order to produce a tiny voltage at its terminals, which is fed to a receiver to be amplified.

Antennas are essential components of all equipment which are used in radio. They are used in broadcasting systems, broadcast television systems, two-way radio systems, communications receiver's systems, radar systems, cell phones systems, and satellite communications systems, garage door openers systems, wireless microphones systems, Bluetooth enabled devices systems, wireless computer networks systems, baby monitors systems, and Radio Frequency Identification (RFID) tags systems on merchandise etc.

### 6.5.1 Types of antennas

There are a very large variety of antennas used in telecommunication. Here we can discuss at least four types of antenna among others.

#### Wire antennas

The wire antennas are dipole, monopole, loop antenna, helix and are usually used in personal applications, automobiles, buildings, ships, aircrafts and super crafts.



Fig.6. 12 Wire antenna

#### Aperture antennas

These are horn antennas and waveguide opening and they are usually used in aircrafts and space crafts because they are flush-mounted.

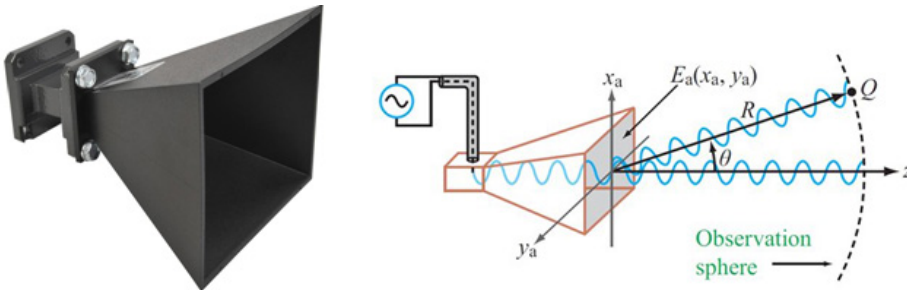

Fig.6. 13: A horn antenna with aperture field distribution

## Reflector antennas

These are parabolic reflectors and corner reflectors and they are high gain antennas usually used in radio astronomy, microwave communication and satellite tracking.



Fig.6. 14: Reflector antenna

## Array antennas

These are also called Yagi-Uda antennas or micro-strip patch arrays or aperture arrays, slotted waveguide arrays. They are suitable for very high gain applications with added advantage, such as, controllable radiation pattern.



Fig.6. 15: Array antenna.

### 6.5.2 Checking my progress

1. What is meant by an antenna in telecommunication system?
2. State and explain at least two types of antenna

## 6.6 BLOCK DIAGRAMS OF TELECOMMUNICATION

### ACTIVITY 6.6: Investigating communication block

Given the system below, discuss the block of communication system provided in the illustration below.

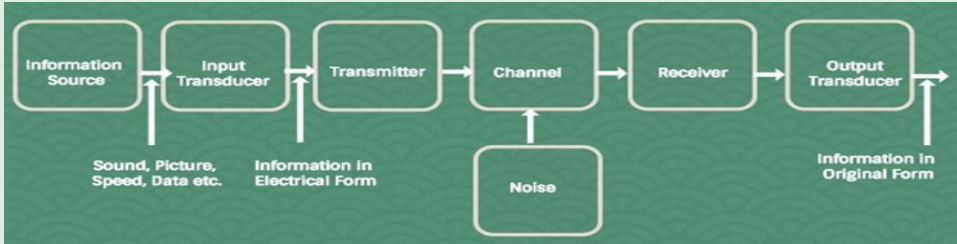

Fig.6. 16: Block-diagram of communication system with input and output transducers

**Information:** Information is any entity or form that resolves uncertainty or provides the answer to a question of some kind. It is thus related to data and knowledge, as data represents values attributed to parameters, and knowledge signifies understanding of real things or abstract concepts. **Message:** A message is a term standing for information put in an appropriate form for transmission. Each message contains information. A message can be either **analog message** (a physical time variable quantity usually in smooth and continuous form) or **a digital message** (an ordered sequence of symbols selected from finite set of elements) as shown in Fig.6.19.

- **Analog message:** a physical time-variable quantity usually in smooth and continuous form.
- **Digital message:** ordered sequence of symbols selected from finite set of elements.

**A signal** is a mathematical function representing the time variation of a physical variable characterizing a physical process and which, by using various models, can be mathematically represented. In telecommunication, the message is also known as a signal and the signal is transmitted in an electrical or voltage form. ( i.e Signal  $\approx$  Message)

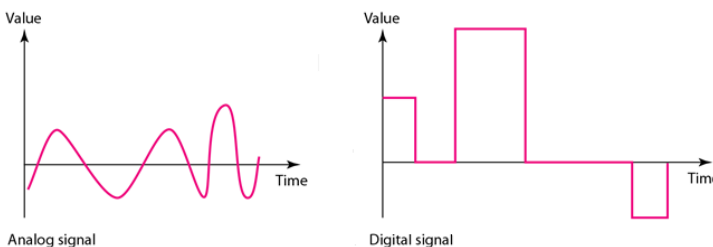

Fig.6. 17: Analog signal and digital signal representation diagram

## COMPARISON OF AN ANALOG SIGNAL TO A DIGITAL SIGNAL

As discussed in the previous section, we can have the summary of differences between analog signal and digital signal (see Table 6.2)

Analog	Digital
Analog technology records the waveforms as they are	Digital technology converts analog waveforms into a set of numbers and records them. The numbers are converted into voltage streams for representation
It uses continuous range of values to represent information	It uses discrete or discontinuous values to represent information
It can be easily affected by noise (other unwanted waves)	It is less affected since the noise responses are analog in nature
The signal is denoted by sine waves	The signal is denoted by square waves
The bandwidth is noted in Hertz	The bandwidth is noted in bits per second

Table 6. 2: Comparison of an analog signal to a digital signal

### SOME ELEMENTS OF BLOCK DIAGRAM OF TELECOMMUNICATION

1. **Transmission channel** which is the electric medium that bridges the distance from source to destination
2. **The receiver** to convert the received signal in a form appropriate for the output transducer after amplifying, filtering, demodulating and decoding it
3. **Output transducer** to convert the output electrical signal the desired message form
4. **Modulation** is defined as the process by which some characteristics (i.e. amplitude, frequency, and phase) of a carrier are varied in accordance with a modulating wave.
5. **Encoding** is the process of coding the message and changes it in the language understandable by the transmitter. This operation is realized at the transmitting end
6. **Demodulation** is the reverse process of modulation, which is used to get back the original message signal. Modulation is performed at the transmitting end whereas demodulation is performed at the receiving end
7. **Decoding** is the reverse process of encoding to retrieve the original message and make it human understandable message. It is realized at the receiving end
8. **Antennas** which are aerials used to transmit and receive the signals.
9. **The oscillators** which are the sources of carrier signals which are used to modulate and help the original signal to reach the destination
10. The signal normally, must be raised at a level that will permit it to reach its destination. This operation is accomplished by **amplifiers**

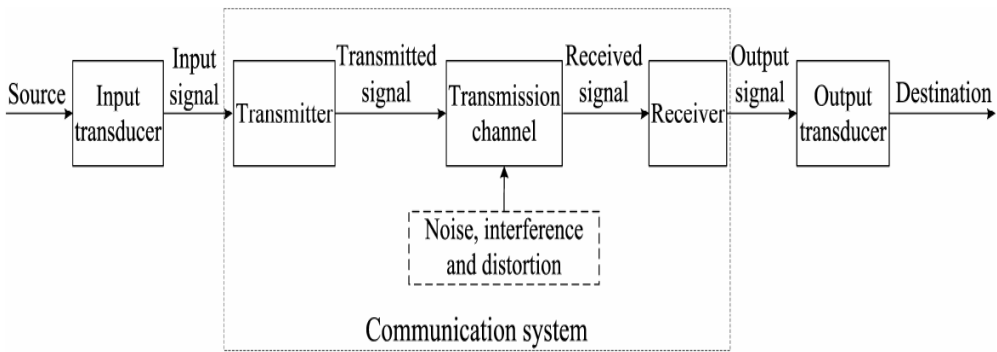

Fig.6. 18: Block diagram of telecommunication

### 6.6.1 Simple radio transmitter

A radio transmitter consists of several elements that work together to generate radio waves that contain useful information such as audio, video, or digital data. The process by which a radio station transmits information is outlined in Fig. 6.21.

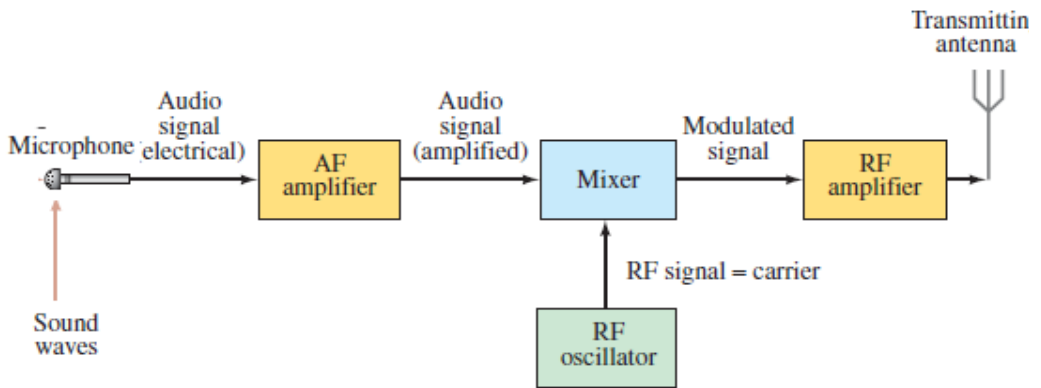

Fig.6. 19: Block diagram of a radio transmitter

- **Power supply:** Provides the necessary electrical power to operate the transmitter.
- The audio (sound) information is changed into an electrical signal of the same frequencies by, say, a microphone, a laser, or a magnetic read write head. This electrical signal is called an **audio frequency (AF) signal**, because the frequencies are in the audio range (20 Hz to 20 000 Hz).
- The signal is amplified electronically in AF amplifier and is then mixed with a radio-frequency (RF) signal called its **carrier frequency**, which

represents that station. AM radio stations have carrier frequencies from about 530 kHz to 1700 kHz. Today's digital broadcasting uses the same frequencies as the pre-2009 analog transmission.

- The **Modulator or Mixer** adds useful information to the carrier wave. The mixing of the audio and carrier frequencies is done in two ways.
  - In amplitude modulation (AM), the amplitude of the high-frequency carrier wave is made to vary in proportion to the amplitude of the audio signal, as shown in Fig.6.3. It is called "amplitude modulation" because the amplitude of the carrier is altered ("modulate" means to change or alter).
  - **In frequency modulation (FM)**, the *frequency* of the carrier wave is made to change in proportion to the audio signal's amplitude, as shown in Fig.7.4. The mixed signal is amplified further and sent to the transmitting antenna (Fig.6.13.C), where the complex mixture of frequencies is sent out in the form of EM waves.
- **Amplifier:** Amplifies the modulated carrier wave to increase its power. The more powerful the amplifier, the more powerful the broadcast.

In digital communication, the signal is put into digital form which modulates the carrier. A television transmitter works in a similar way, using FM for audio and AM for video; both audio and video signals are mixed with carrier frequencies.

### 6.6.2 Simple radio receiver

A radio receiver is the opposite of a radio transmitter. It uses an antenna to capture radio waves, processes those waves to extract only those waves that are vibrating at the desired frequency, extracts the audio signals that were added to those waves, amplifies the audio signals, and finally plays them on a speaker.

Now let us look at the other end of the process, the reception of radio and TV programs at home. A simple radio receiver is graphed in Fig. 6.22. The EM waves sent out by all stations are received by the antenna.

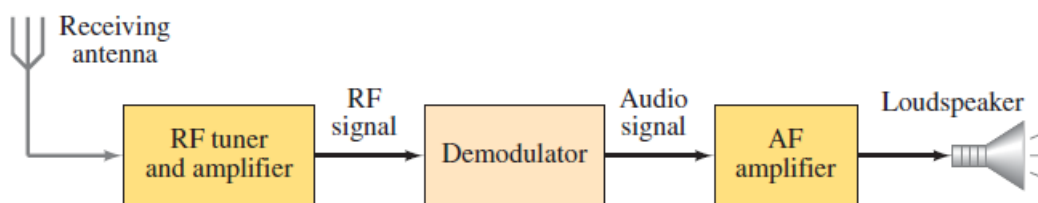

Fig.6. 20 Block diagram of a simple radio receiver

The signal **antenna** detect and send the radio waves, to the receiver are very small and contain frequencies from many different stations. The receiver uses a resonant  $LC$  circuit to select out a particular RF frequency (actually a narrow range of frequencies) corresponding to a particular station.

A simple way of tuning a station is shown in Fig.6.23. When the wire of antenna is exposed to radio waves, the waves induce a very small alternating current in the antenna.

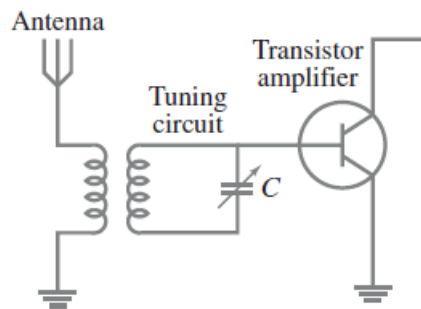

Fig.6. 21: Simple tuning stage of a radio.

A particular station is “tuned in” by adjusting the capacitance  $C$  and/or inductance  $L$  so that the resonant frequency of the circuit equals that of the station’s carrier frequency. R.F. Amplifier: A sensitive amplifier that amplifies the very weak radio frequency (RF) signal from the antenna so that the signal can be processed by the tuner.

R.F. Tuner: A circuit that can extract signals of a particular frequency from a mix of signals of different frequencies. On its own, the antenna captures radio waves of all frequencies and sends them to the RF amplifier, which dutifully amplifies them all. Unless you want to listen to every radio channel at the same time, you need a circuit that can pick out just the signals for the channel you want to hear. That’s the role of the tuner.

The tuner usually employs the combination of an inductor (for example, a coil) and a capacitor to form a circuit that resonates at a particular frequency. This frequency, called the *resonant frequency*, is determined by the values chosen for the coil and the capacitor. This type of circuit tends to block any AC signals at a frequency above or below the resonant frequency.

You can adjust the resonant frequency by varying the amount of inductance in the coil or the capacitance of the capacitor. In simple radio receiver circuits, the tuning is adjusted by varying the number of turns of wire in the coil. More sophisticated tuners use a variable capacitor (also called a *tuning capacitor*) to vary the frequency.

### 6.6.3 Wireless Radio Communication

Let us now discuss the basic principles of wireless radio communications. We shall mainly concentrate on the principle of amplitude modulation and demodulation. The simplest scheme of wireless communication would be to convert the speech or music to be transmitted to electric signals using a microphone, boost up the power of the signal using amplifiers and radiate the signal in space with the aid of an antenna. This would constitute the transmitter. At the receiver end, one could have a pick-up antenna feeding the speech or music signal to an amplifier and a loud speaker. (See Fig.6.24)

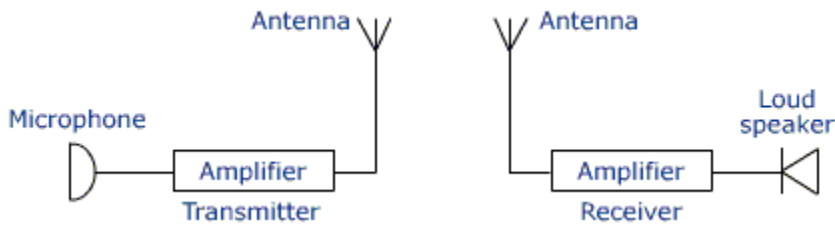

Fig.6. 22 Wireless radio communication

**The above scheme suffers from the following drawbacks:**

- i. EM waves in the frequency range of 20 Hz to 20 kHz (audio-frequency range) cannot be efficiently radiated and do not propagate well in space.
- ii. Simultaneous transmission of different signals by different transmitters would lead to confusion at the receiver.

In order to solve these problems; we need to devise methods to convert or translate the audio signals to the radio-frequency range before transmission and recover the audio-frequency signals back at the receiver. Different transmitting stations can then be allotted slots in the radio-frequency range and a single receiver can then tune into these transmitters without confusion.

The frequency range 500 kHz to 20 MHz is reserved for amplitude-modulated broadcast, which is the range covered by most three band transistor radios. The process of frequency translation at the transmitter is called modulation. The process of recovering the audio-signal at the receiver is called demodulation. A simplified block diagram of such a system is shown in the below figure.

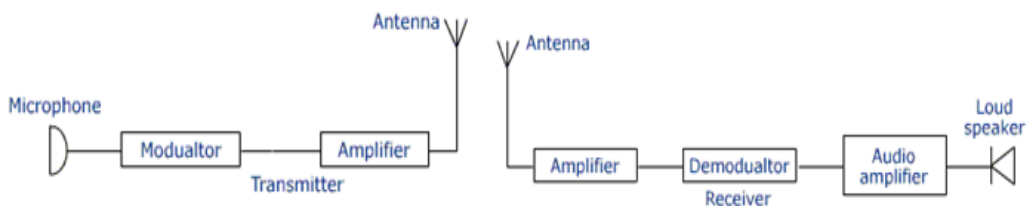

Fig.6. 23 Block diagram of radio transmitter and receiver

### 6.6.4 Checking my progress

1. What is the importance of power amplifier in simple radio transmitter.
2. What do you understand by the following terms.
3. Analog message
4. Digital message
5. Draw a circuit diagram of a simple radio receiver

## END UNIT ASSESSMENT 6

### A. Multiple choices

1. One of the following is used for satellite communication
  - a. Radio waves
  - b. Light waves
  - c. Microwaves
  - d. All of these
2. Amplitude –modulated radio waves are received by a tuned radio-frequency ( trf) Receiver. The receiver has a suitable detector circuit in order to
  - a. Amplifier the carrier waves
  - b. Amplifier the audio-frequencies carried
  - c. Rectifier the carrier waves
  - d. detect the carrier waves
  - e. Transfer the audio-frequencies to the radio-frequency amplifier

### B. Structured questions

3. What do you understand by the following terms?
  - a. Amplifier
  - b. Modulator
4. What is meant by telecommunication system?
5. Draw a labeled diagram showing the elements of radio transmitter

### C. Essay question

6. Recently, the government of Rwanda decided to replace analog system of communication by digital system of communication. Debate about this government policy
7. Explain briefly positive impact of telecommunication in development of a country like Rwanda.

# UNIT 7

## NATURE OF PARTICLES AND THEIR INTERACTIONS



**Key unit competence:** Organize the properties and basic principles of quarks.

### My goals

- The key varieties of fundamental subatomic particles and how they were discovered.
- Distinguish between fundamental particles and composite particles
- Distinguish between particles and antiparticles
- Describe how antimatter can be used as a source of energy
- State some applications for elementary particles
- Compare matter and antimatter
- The four ways in which subatomic particles interact with each other.
- Analyze the structure of protons, neutrons, and other particles can be explained in terms of quarks

## INTRODUCTORY ACTIVITY

### Investigating the elementary particles discovery

In the study of matter description and energy as well as their interactions; the fascinating thing of discovery is the structure of universe of unknown radius but still to know the origin of matter one need to know about small and smallest composites of matter. The smallest particle was defined to be electron, proton, and neutron. But one can ask:

1. Are electron, proton and neutron the only particle that can define the origin of matter?
2. What are other particles matter is composed of?
3. Describe and discuss how particles interact with energy to form matter.

## 7.1 ELEMENTARY PARTICLES.

### 7.1.1 Introduction

#### ACTIVITY 7.1: Investigate the presence of smaller particles

1. Use internet and retrieve the definition and the information about elementary particles, and then answer to the following questions.
2. What does elementary particle physics talk about?
3. What are the elementary particles found through your research?
4. Discuss and explain the use of knowledge about the elementary particles.

Particle physics, also known as **high-energy** physics, is the field of natural science that pursues the ultimate structure of matter.

The **protons** and **neutrons** are collectively called **hadrons**, were considered as elementary particles until 1960. We now know that they are composed of more fundamental particles, the **quarks**. **Electrons** remain elementary to this day. **Muons** and  **$\tau$ -leptons**, which were found later, are nothing but heavy electrons, as far as the present technology can tell, and they are collectively dubbed **leptons**.

**Quarks and leptons are the fundamental building blocks of matter.** The microscopic size that can be explored by modern technology is nearing  $10^{-19} m$ . The quarks and leptons are elementary at this level (Nagashima, 2013).

**Particle physics** is the study of the fundamental constituents of matter and their interactions. However, which particles are regarded as fundamental have changed with time as physicists' knowledge has improved. Modern theory called the **standard model** attempts to explain all the phenomena of particle physics in terms of the **properties** and **interactions** of a small number of particles of three distinct types (see Fig.7.1):

- Two families of fermions (of spin  $\frac{1}{2}$ ): leptons and quarks
- One family of bosons (of spin 1)

	I	II	III		
mass→	2.4 MeV	1.27 GeV	171.2 GeV	0	$\approx 125.09 \text{ GeV}/c^2$
charge→	$\frac{2}{3}$	$\frac{2}{3}$	$\frac{2}{3}$	0	0
spin→	$\frac{1}{2}$	$\frac{1}{2}$	$\frac{1}{2}$	1	0
name→	<b>u</b> up	<b>c</b> charm	<b>t</b> top	$\gamma$ photon	<b>H</b> Higgs
					SCALAR BOSONS
<b>Quarks</b>	4.8 MeV $-\frac{1}{3}$ $\frac{1}{2}$ <b>d</b> down	104 MeV $-\frac{1}{3}$ $\frac{1}{2}$ <b>s</b> strange	4.2 GeV $-\frac{1}{3}$ $\frac{1}{2}$ <b>b</b> bottom	0 0 1 <b>g</b> gluon	
	<2.2 eV 0 $\frac{1}{2}$ <b><math>\nu_e</math></b> electron neutrino	<0.17 MeV 0 $\frac{1}{2}$ <b><math>\nu_\mu</math></b> muon neutrino	<15.5 MeV 0 $\frac{1}{2}$ <b><math>\nu_\tau</math></b> tau neutrino	91.2 GeV 0 1 <b>Z<sup>0</sup></b> weak force	
					Bosons (Forces)
<b>Leptons</b>	0.511 MeV -1 $\frac{1}{2}$ <b>e</b> electron	105.7 MeV -1 $\frac{1}{2}$ <b><math>\mu</math></b> muon	1.777 GeV -1 $\frac{1}{2}$ <b><math>\tau</math></b> tau	80.4 GeV $\pm 1$ 1 <b>W<sup>±</sup></b> weak force	

Fig.7. 1 Fundamental Standard model of elementary particle

I, II and III represent the first, second and the third generations. In addition, at least one spin-0 particle, called the *Higgs boson*, is postulated to explain the origin of mass within the theory, since without it all the particles in the model are predicted to have zero mass (see Fig.7.1).

All the particles of the standard model are assumed to be *elementary*; i.e. they are treated as point particles, without internal structure or excited states. The most familiar example of a lepton is the *electron*  $e^-$  (the superscript denotes the electric charge), which is bound in atoms by the *electromagnetic interaction*, one of the four fundamental forces of nature. A second well-known lepton is the *electron neutrino*, which is a light, neutral particle observed in the decay products of some unstable nuclei (the so-called  $\beta$ -decays). The force responsible for the  $\beta$ -decay of nuclei is called the *weak interaction*.

### 7.1.2 Checking my progress

1. Particles that make up the family of Hadrons are:
  - a. Baryons and mesons
  - b. Leptons and baryons
  - c. Protons and electrons
  - d. Muons and Leptons
2. Using the elementary particles, Complete the following sentences
  - I. One family of bosons of spin 1 called \_\_\_\_\_ which act as 'force carriers' in the theory
  - II. Two fermions of spin 1/2 called \_\_\_\_\_ and \_\_\_\_\_
3. The first antiparticle found was the
  - a. Positron
  - b. Hyperons
  - c. Quark
  - d. baryon
4. Explain what is meant by particle physics?

## 7.2 CLASSIFICATION OF ELEMENTARY PARTICLES.

### ACTIVITY 7.1: Classes of elementary particles

Based on the previous introduction section, reread the text and the answer to the following questions.

1. What are the types of elementary particles?
2. What properties are based on to classify elementary particles?

There are three properties that describe an elementary particle "**mass**," "**charge**" and "**spin**". Each property is assigned as number value. These properties always stay the same for an elementary particle.

- **Mass (m)**: a particle has mass if it takes energy to increase its speed or to accelerate it. The values are given in  $\text{MeV}/c^2$ . This comes from special relativity, which tells us that energy equals mass times the square of the speed of light.  $E = m \times c^2$ . All particles with mass are affected by gravity even particles with no mass like photon.
- **Electriccharge (Q)**: particles may have positive, negative charge or none. If one particle has a negative charge and another particle has a positive, the two particles are attracted to each other. If particles have a similar charge, they repel each other. At a short distance this force is much stronger than the force of gravity which pulls all particles together. An electron has a charge -1 and a proton has a charge +1. A neutron has average charge 0. Normal quarks have charge of  $2/3$  or  $-1/3$

- **Spin:** the angular momentum or constant turning of particles has a particular value, called its spin number. Spin for elementary particle is 0, 1 or  $\frac{1}{2}$ . The spin property only denotes the presence of angular momentum.

### 7.2.1 Classification of particles by mass

The most basic way of classifying particles is by their mass. The heaviest particles are the **hadrons** and the lightest one is the **leptons**.

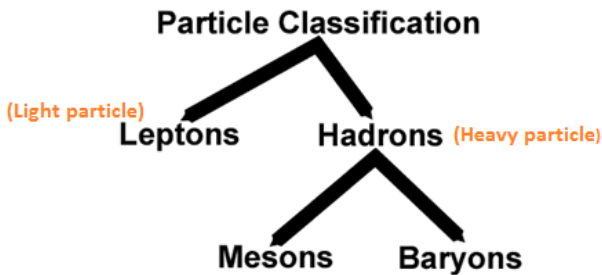

Fig.7. 2 Particles classification by mass

As seen the diagram above **hadrons group** is divided into **baryons** and mesons. **Baryons** are the heaviest particles and are followed by mesons.

**Hadrons** are composite particles made of quarks held together by the strong force in a similar way as molecules are held together by electromagnetic force. They are subjected to the strong nuclear force and are not fundamental particles as they are made up of quarks.

- **Baryons** are composite sub-atomic particle made up of 3 quarks (tri-quarks are distinct from mesons which are composed of one quark and one antiquark). Baryon comes from Greek word which means “**heavy**”. The protons are only stable baryons; all other baryons eventually decay into proton.

**Ex:** Protons and neutrons.

- **Mesons** are hadrons sub-atomic particles made up of one quark and one anti-quark bound together by strong interaction. **Ex:** Pion and kaon

Each pion has quark and one anti-quark therefore is a meson. It is the lightest meson and generally the lightest hadrons. They are unstable.

**Leptons** do not interact via the strong force. They carry electric charge also interact via the weak nuclear force. They include electron, muons, tau and three the types of neutrino: the electron neutrino ( $\nu_e$ ), the muon neutrino ( $\nu_\mu$ ) and the tau neutrino ( $\nu_\tau$ ).

In summary, leptons are subjected to the weak nuclear force and they do not feel the strong nuclear force.

**Examples:** Electron, muons and neutrino.

### 7.2.2 Classification of particles by spin.

The spin classification determines the nature of energy distribution in a collection of particles. Particles of integer spin obey **Bose-Einstein statistics** whereas those of half-integer spin behave according to **Fermi-Dirac statistics** as shown in the following chart

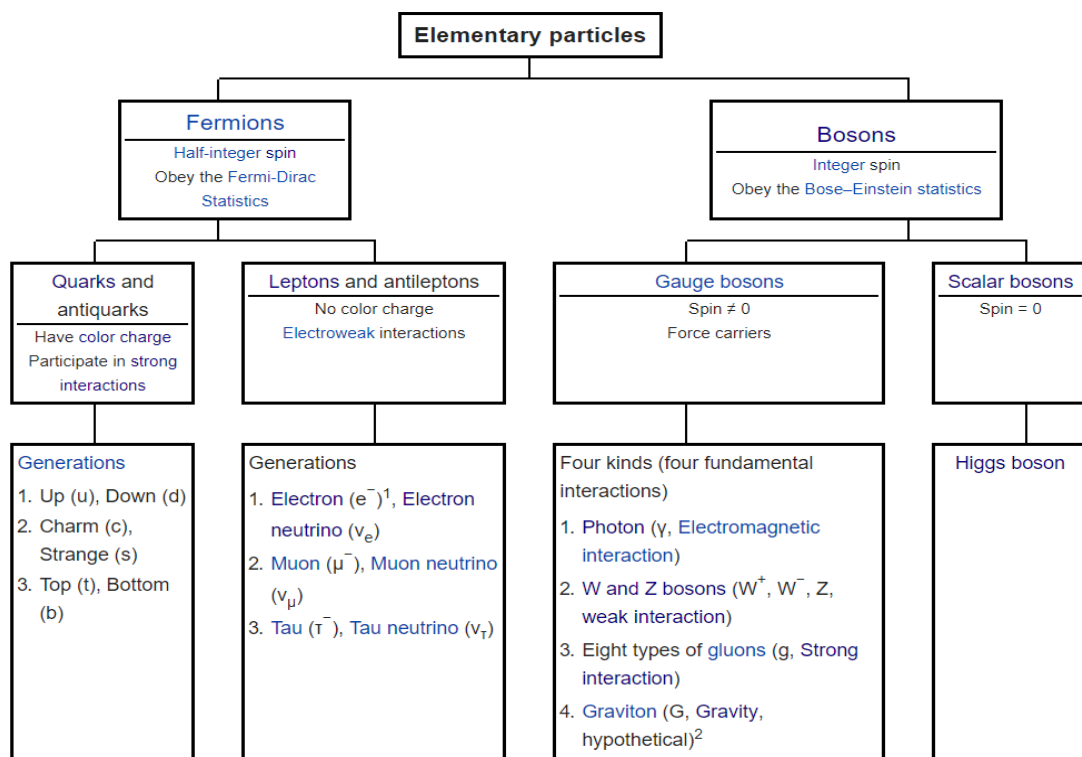

All fundamental particles are classified into fermions and bosons. Fermions have half-integer spin while bosons have full integer spin. Electrons and nucleons are fermions with spin  $\frac{1}{2}$ . The fundamental bosons have mostly spin 1. This includes the photon. The pion has spin 0, while the graviton has spin 2. There are also three particles, the  $W^+$ ,  $W^-$  and  $Z^0$  bosons, which are spin 1. They are the carriers of the weak interactions.

Fermions are particles which have half-integer spin and therefore are constrained by the **Pauli Exclusion Principle** (see Section 7.4). It includes electrons, protons and neutrons.

The fact that electrons are fermions is foundational to the buildup of the periodic table of elements since there can be only one electron for each state in an atom (only one electron for each possible set of quantum numbers). The fermion nature of electrons also governs the behavior of electrons in a metal where at low temperatures all the low energy states are filled up to a level called the **Fermi energy**. This filling of states is described by **Fermi-Dirac statistics**.

### 7.2.3 Checking my progress

1. How can elementary particles be classified?
2. Elementary particles which are made up of one quark and one anti-quark are called
  - a. Protons
  - b. Neutrons
  - c. Baryons
  - d. Mesons
  - e. Leptons
3. The Sub-atomic particle made up of 3 quarks are called
  - a. Leptons
  - b. Pion
  - c. kaon
  - d. Baryons
4. What do you understand by the term elementary particle? .

## 7.3 ANTI PARTICLE AND PAULI'S EXCLUSION PRINCIPLE

### 7.3.1 Concept of particle and antiparticle

#### ACTIVITY 7.3

Discuss the following terms:

1. Particle
2. Antiparticle

There are two important points about pair production. The first is that you need to collect energy to produce the electron-positron pair. You need the equivalent rest mass of energy that is the amount of energy contained in the both particle and anti-particle when at rest. The energy converted to mass is 'lost' or fully "bound" until the particle is annihilated and the energy can be recovered. The second thing is that it needs a correct environment. The process does not occur unless certain conditions are present.

Viewing the phenomena as a creative process we can say a threshold amount of energy is sacrificed in a correct context to manifest a pair of particle with a physical mass. It can be said something was created out of nothing. That is

before the interaction, no particles with mass existed. After interaction, there were two particles with mass. Hence something was created out of nothing. But this can be said only because of the perspective taken when viewing the process.

**For every charged particle of nature, whether it is one of the elementary particles of the standard model, or a hadron, there is an associated particle of the same mass, but opposite charge, called its *antiparticle*.**

This result is a necessary consequence of combining special relativity with quantum mechanics. This important theoretical prediction was made by Dirac and follows from the solutions of the equation he first wrote down to describe relativistic electrons

### **7.3.2 Pauli's exclusion principle,**

Pauli's exclusion principle is a quantum mechanical principle which states that:

“Two or more identical fermions (particles with half-integer spin) cannot occupy the same quantum state simultaneously.”

In case of electrons in atoms it can be stated as follows: it is impossible for two electrons of a poly-electron atom to have the same values of the four quantum numbers:

The principle quantum number ( $n$ ), the angular momentum quantum number ( $l$ ), the magnetic quantum number ( $m_l$ ) and the spin quantum number ( $m_s$ ).

For example, if two electrons reside in the same orbital and if their  $m_s$  must be different and thus like electrons must have opposite half integer spin projections of  $\frac{1}{2}$  and  $-\frac{1}{2}$ .

This principle was formulated by Austrian physicist Wolfgang Pauli in 1925 for electrons, and later extended to all fermions with his spin–statistics theorem of 1940.

Particles with an integer spin, or bosons, are not subject to the Pauli Exclusion Principle: any number of identical bosons can occupy the same quantum state, for instance, photons produced by a laser and Bose–Einstein condensate.

The Pauli Exclusion Principle describes the behavior of all fermions (particles with “half-integer spin”), while bosons (particles with “integer spin”) are subject to other principles. Fermions include elementary particles such

as quarks, electrons and neutrinos. Additionally, baryons such as protons and neutrons (subatomic particles composed from three quarks) and some atoms (such as helium-3) are fermions, and are therefore described by the Pauli Exclusion Principle as well.

### 7.3.3 Checking my progress

1. What do you understand by antiparticle?
2. State Pauli's exclusion principle?
3. Why Pauli's exclusion Principle is known as exclusion?

## 7.4 FUNDAMENTAL INTERACTIONS BY PARTICLE EXCHANGE

### ACTIVITY 7.4: Fundamental interaction

Using internet, discuss the fundamental interactions in terms of exchange particles, then find the relation between the following concepts.

1. Gravitational forces
2. electroweak force,
3. Strong force and
4. Weak forces.

### 7.4.1 Forces and Interactions

Physicists have recognized three basic forces:

- The **gravitational force** is an inherent attraction between two masses. Gravitational force is responsible for the motion of the planets and Stars in the Universe. It is carried by **Graviton**. By Newton's law of gravitation, the gravitational force is directly proportional to the product of the masses and inversely proportional to the square of the distance between them. Gravitational force is the weakest force among the fundamental forces of nature but has the greatest large-scale impact on the universe. Unlike the other forces, gravity works universally on all matter and energy, and is universally attractive
- The **electric force** is a force between charges
- The **magnetic force**, which is a force between magnets or between magnetic body and ferromagnetic body.

In the 1860s, the Scottish physicist James Clerk Maxwell developed a theory that **unified** the electric and magnetic forces into a single electromagnetic force. Maxwell's electromagnetic force was soon found to be the "glue" holding atoms, molecules, and solids together. It is the force between charged particles such as the force between two electrons, or the force between two current carrying wires. It is attractive for unlike charges and repulsive for like charges. The

electromagnetic force obeys inverse square law. It is very strong compared to the gravitational force. It is the combination of electrostatic and magnetic forces.

The discovery of the atomic nucleus, about 1910, presented difficulties that could not be explained by either gravitational or electromagnetic forces. The atomic nucleus is an unimaginably dense ball of protons and neutrons. But what holds it together against the repulsive electric forces between the protons? There must be an attractive force inside the nucleus that is stronger than the repulsive electric force. This force, called the **strong force**, is the force that holds the protons and neutrons together in the nucleus of an atom. It is the strongest of all the basic forces of nature. It, however, has the shortest range, of the order of  $10^{-15}$  m. This force only acts on quarks. It binds quarks together to form baryons and mesons such as protons and neutrons. The strong force is mediated or carried by Gluons. Quarks carry electric charge so they experience electric and magnetic forces.

In the 1939, physicists found that the nuclear radioactivity called **beta decay** could not be explained by either the electromagnetic or the strong force. Careful experiments established that the decay is due to a previously undiscovered force within the nucleus. The strength of this force is less than either the strong force or the electromagnetic force, so this new force was named **the weak force**. Weak nuclear force is important in certain types of nuclear process such as  $\beta$ -decay. This force is not as weak as the gravitational force. The weak force acts on both leptons and quarks (and hence on all hadrons). The weak force is carried by  $W^+$ ,  $W^-$  and  $Z$ . Leptons – the electrons, muons and tau – are charged so they experience electric and magnetic forces.

Of these, our everyday world is controlled by gravity and electromagnetism. The strong force binds quarks together and holds nucleons (protons & neutrons) in nuclei. The weak force is responsible for the radioactive decay of unstable nuclei and for interactions of neutrinos and other leptons with matter.

By 1940, the recognized forces of nature (**fundamental forces**) were four:

- Gravitational forces between masses,
- Electromagnetic forces resulting from the combination of electric and magnetic fields,
- Strong force (nuclear force) between subatomic particles,
- Weak forces that arise in certain radioactive decay processes.

By 1980, Sheldon Glashow, Abdus Salam, and Steven Berg developed a theory that unifies electromagnetism and weak force into electroweak force. Hence,

our understanding of the forces of nature is in terms of **three** fundamental forces:

- The gravitational force,
- The electroweak force,
- The strong force.

**The Table 7.1 below summaries the fundamental forces and force carriers.**

Force	Carriers	Symbol	charge	Mass
Electromagnetic	Photon	$\gamma$	0	0
Strong	Gluon	$g$	0	0
Weak	W boson	$W^+$ $W^-$	+ -	80.1 GeV 80.6 GeV
	Z boson	$Z$	0	91.2 GeV
Gravitational	Graviton	$G$	0	0

Table 7.1 Forces and their carriers

- **W boson:** short-lived elementary particle; one of the carriers of the weak nuclear force
- Z boson: short-lived elementary particle; one of the carriers of the weak nuclear force
- Graviton: the hypothetical particle predicted to carry the gravitational force

All the forces of nature should be capable of being described by single theory. But only at high energies should be the behavior of the forces combines, this is called unification. We can compare the relative strengths of the electromagnetic *repulsion* and the gravitational *attraction* between two protons of unit charge using the above equations.

Force	Relative strength	Gauge Boson	Mass (relative to proton)	Charge	Spin
Strong	1	Gluon (g)	0	0	1
Electromagnetic	$\frac{1}{137}$	Photon ( $\gamma$ )	0	0	1
Weak	$10^{-9}$	$W^\pm, Z$	86, 97	$\pm 1, 0$	1
Gravity	$10^{-38}$	Graviton (G)	0	0	2

Table 7.2 Forces and their quanta, the gauge bosons and charge in units of electron charge.

## EXAMPLE 7.1

The 2 up quarks (u) in a proton are separated by a distance  $r = 1 \times 10^{-15} \text{ m}$ . These quarks each have an electric charge  $+\frac{2}{3}e$ , and mass of  $m_u = 7 \times 10^{-30} \text{ kg}$  so they repel each other through an electric force obeying Coulomb's law. They also attract each other through a gravitational force. What is the ratio of the magnitude of the electric and gravitational forces between these 2 quarks?

**Answer:**

$$\text{Gravitational force: } F_{gr} = G \frac{m_u m_u}{R^2}$$

$$\text{Electric force: } F_{el} = K \frac{q_u q_u}{R^2}$$

$$\text{Divided by: } \frac{F_{gr}}{F_{el}} = \frac{G \frac{m_u m_u}{r^2}}{k \frac{q_u q_u}{r^2}} = \frac{9Gm^2}{4ke^2} = \frac{9(6.67 \times 10^{-11} \text{ N} \cdot \frac{\text{m}^2}{\text{kg}^2})(7 \times 10^{-30} \text{ kg})^2}{4(8.99 \times 10^9 \text{ N} \cdot \frac{\text{m}^2}{\text{C}^2})(1.6 \times 10^{-19} \text{ C})^2} = 3 \times 10^{-41}$$

Thus the gravitational is the weakest of the fundamental forces. These interactions and their relative strengths are summarized in Table 7.1

### 7.4.2 Checking my progress

1. Particles that interact by the strong force are called:

- |            |              |
|------------|--------------|
| a. Leptons | c. Muons     |
| b. hadrons | d. Electrons |

2. Name the four fundamental interaction and the particles that mediate each

## 7.5 UNCERTAINTY PRINCIPLE AND PARTICLE CREATION

### 7.5.1 The concept of uncertainty principle

#### ACTIVITY 7.5: Investigation of particle creation and position.

Basing on the knowledge and skills obtained from the previous sections of this unit, use internet to find the meaning of the particle creation.

- Is it possible to know the exact location of an elementary particle?
- Discuss and explain your findings

The discovery of the dual wave–particle nature of matter forces us to re-evaluate the kinematic language we use to describe the position and motion of a particle.

In classical Newtonian mechanics we think of a particle as a point. We can describe its location and state of motion at any instant with three spatial coordinates and three components of velocity. But because matter also has a wave aspect, when we look at the behaviour on a small enough scale comparable to the de Broglie wavelength of the particle we can no longer use the Newtonian description. Certainly no Newtonian particle would undergo diffraction like electrons do.

To demonstrate just how non Newtonian the behaviour of matter can be, let's look at an experiment involving the two-slit interference of electrons (Fig.7.4). We aim an electron beam at two parallel slits, just as we did for light. (The electron experiment has to be done in vacuum so that the electrons don't collide with air molecules.)

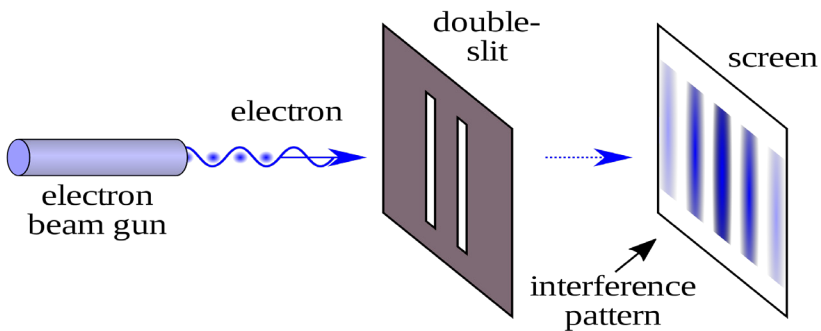

Fig.7.3 Experiment involving the two-slit interference of electrons

What kind of pattern appears on the detector on the other side of the slits?

The answer is: *exactly the same* kind of interference pattern we saw for photons. Moreover, the principle of complementarity, tells us that we cannot apply the wave and particle models simultaneously to describe any single element of this experiment. Thus we *cannot* predict exactly where in the pattern (a wave phenomenon) any individual electron (a particle) will land. We can't even ask which slit an individual electron passes through. If we tried to look at where the electrons were going by shining a light on them that is, by scattering photons off them the electrons would recoil, which would modify their motions so that the two-slit interference pattern would not appear.

Just as electrons and photons show the same behaviour in a two-slit interference experiment, electrons and other forms of matter obey the same Heisenberg uncertainty principles as photons do:

Heisenberg uncertainty principle for position and momentum is given by

$$(\Delta x \Delta p) \geq \frac{\hbar}{2\pi}$$

$$(\Delta x)(\Delta p_x) \geq \frac{h}{4\pi} \quad (7.03)$$

This is a mathematical statement of the **Heisenberg uncertainty principle** Or it is sometimes called, the **indeterminacy principle**. It tells us that we cannot measure both the position and momentum of an object precisely at the same time.

The uncertainty principle relates energy and time, examining this as follows. The object to be detected has an uncertainty in position  $\Delta x \approx \lambda$ . the photon that detects it travels with speed  $c$ , and it takes a time  $\Delta t \approx \frac{\Delta x}{c} \approx \frac{\lambda}{c}$  to pass through the distance of uncertainty.

Hence, the measured time when our object is at given position is uncertain by about  $\Delta t \approx \frac{\lambda}{c}$  since the photon can transfer some or all of energy  $E = hf = \frac{hc}{\lambda}$  To our object, the uncertainty in energy of our object as result is  $\Delta E \approx \frac{hc}{\lambda}$

The product of these two uncertainties is  $(\Delta E)(\Delta t) \approx h$  . A more careful calculation gives

$$(\Delta E)(\Delta t) \geq \frac{h}{4\pi} \quad (7.04)$$

The quantity  $\frac{h}{2\pi}$  appears so often in quantum mechanics that for convenience is

given the symbol  $\hbar$  ("h-bar").  $\hbar = \frac{h}{2\pi} = \frac{6.626 \times 10^{-34} \text{ J}\cdot\text{s}}{2\pi} = 1.055 \times 10^{-34} \text{ J}\cdot\text{s}$ .

$$\text{Thus } (\Delta x)(\Delta p_x) \geq \frac{\hbar}{2} \text{ and } (\Delta E)(\Delta t) \geq \frac{\hbar}{2} \quad (7.05)$$

## 7.5.2 Checking my progress

1. The idea of uncertainty is used in many contexts; social, economic and scientific. People often talk about uncertain times, and when you perform a measurement you should always estimate the uncertainty (sometimes called the error). In physics the Heisenberg Uncertainty relation has a very specific meaning.
  - a. Write down the Heisenberg uncertainty relation for position and momentum.
  - b. Explain its physical significance.
  - c. Does the Heisenberg uncertainty principle need to be considered when calculating the uncertainties in a typical first year physics experiment? Why or why not?
  - d. Discuss the following statement: the uncertainty principle places a limit on the accuracy with which a measurement can be made. Do you agree or disagree, and why?
2. An electron is confined within a region of width  $5 \times 10^{-11} \text{ m}$  (Roughly the Bohr radius)
  - a. Estimate the minimum uncertainty in the component of the electron's momentum.
  - b. What is the kinetic energy of an electron with this magnitude of momentum? Express your answer in both joules and electron volts.

## 7.6 MATTER AND ANTIMATTER (PAIR PRODUCTION AND ANNIHILATION)

### ACTIVITY 7.5: Describing the matter and antimatter

Use internet to describe the following concepts:

1. Matter and give examples of matter particles
2. Antimatter and give examples of antimatter particles
3. Pair production
4. Annihilation

### 7.6. 1 Introduction

**Matter** is a substance that has mass and takes up a space by having a volume. This include atoms and anything made up of these but no other energy phenomena or wave such as light or sound. Everything around you is made up of matter and is composed of particles including the fundamental fermions (quarks,

leptons, antiquarks and antileptons) which generally are matter particles and antimatter particles.

**Antimatter** is a material composed of the antiparticle to the corresponding particle or ordinary particles. In theory a particle and its antiparticle have the same mass as one another but opposite electric charge and other differences in quantum numbers. Neutrons have antineutrons, electrons have positrons and neutrons have antineutrons as their respective antimatter. It was once thought that matter would neither be created nor destroyed. We know that energy and mass are interchangeable.

### 7.6.2 Pair production and annihilation

**Pair production** is a crucial example that photon energy can convert into kinetic energy as well as rest mass energy. Schematic diagram about the process of pair production is shown in Fig.7.5. The high-energy photon that has energy  $hf$  loses its entire energy when it collides with nucleus. Then, it makes pair of electron and positron and gives kinetic energy to each particle.

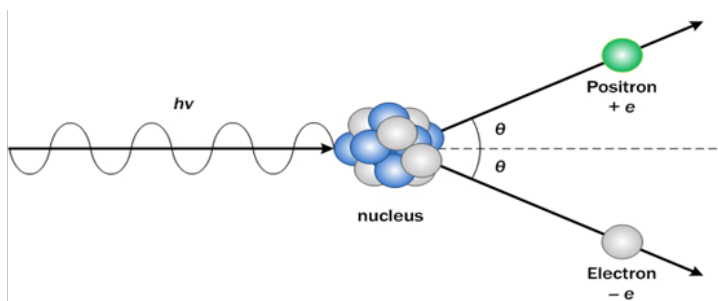

Fig.7. 5 Schematic diagram about the process of pair production

**Annihilation:** When a particle collides with its antiparticle, the two annihilate each other with their mass being entirely converted into energy by the process called "**Annihilation**"

These particles and anti-particles can meet each other and **annihilate** one another (See Fig.7.6). In each case the particle and its antiparticle annihilate each other, releasing a pair of high energy gamma photons.

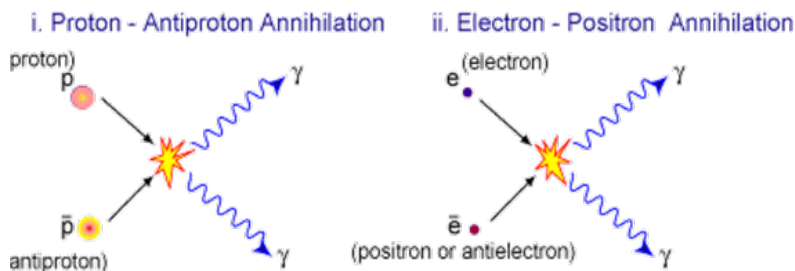

Fig.7. 4: Annihilation process during pair-production.

In this example, a proton and an anti-proton meet each other and annihilate, producing high energy gamma rays in the form of photons. Rest mass, charge, momentum and energy are conserved. They can also be produced from a high energy photon, this is called **pair production**.

### *7.6.3 Application of antimatter*

Antimatter as a form of antiparticle of sub atomic particles has a variety of applications:

- Positron emission tomography can be used to potentially treat cancer.
- Stored antimatter can be used for interplanetary and inter stellar travel.
- Antimatter reactions have practical applications in medical energy.
- Antimatter has been considered as a trigger mechanism for nuclear weapons because whenever antimatter meets its corresponding matter the energy is released by annihilation.

### *7.6.4 Checking my progress*

1. Antimatter as a form of sub atomic particles
  - a. Electron
  - b. proton
  - c. matter
  - d. antiparticle
  - e. none of them is correct
2. The process in which a particle and antiparticle unite annihilate each other and produce one or more photons is called.....
3. What happens when matter and antimatter collide?
4. Compare matter and antimatter

## END UNIT ASSESSMENT 7

### A. Multiple choices

1. The positron is called the antiparticle of electron, because it
  - a. Has opposite charge and Annihilates with an electron
  - b. Has the same mass
  - c. Collides with an electron
  - d. Annihilates with an electron
2. Beta particles are
  - e. Neutrons
  - f. Protons
  - g. Electrons
  - h. Thermal neutrons
3. If gravity is the weakest force, why is it the one we notice most?
  - a. Our bodies are not sensitive to the other forces.
  - b. The other forces act only within atoms and therefore have no effect on us.
  - c. Gravity may be “very weak” but always attractive, and the Earth has enormous mass. The strong and weak nuclear forces have very short range. The electromagnetic force has a long range, but most matter is electrically neutral.
  - d. At long distances, the gravitational force is actually stronger than the other forces.
  - e. The other forces act only on elementary particles, not on objects our size.

### B. Structured questions

4. According to the classification of elementary particles by mass. Complete the following figure

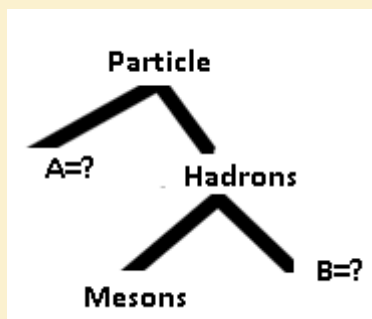

5.

- I. State two differences between a proton and a positron.
- II. A narrow beam of protons and positrons travelling at the same speed enters a uniform magnetic field. The path of the positrons through the field is shown in Fig.7.7. Sketch on this figure the path you would expect the protons to take.

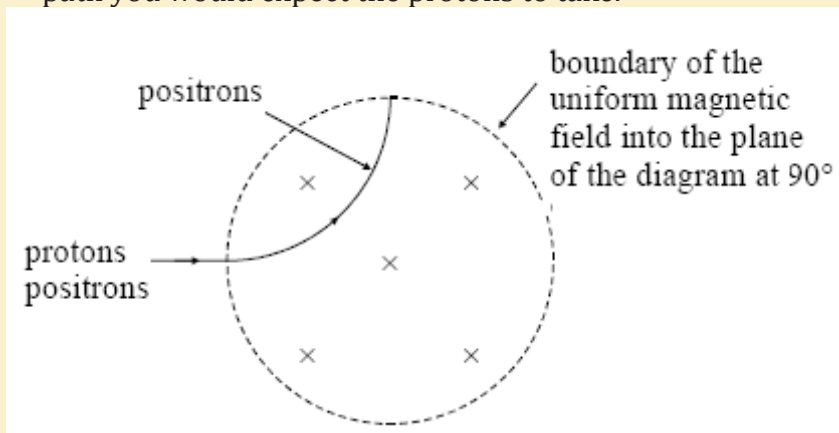
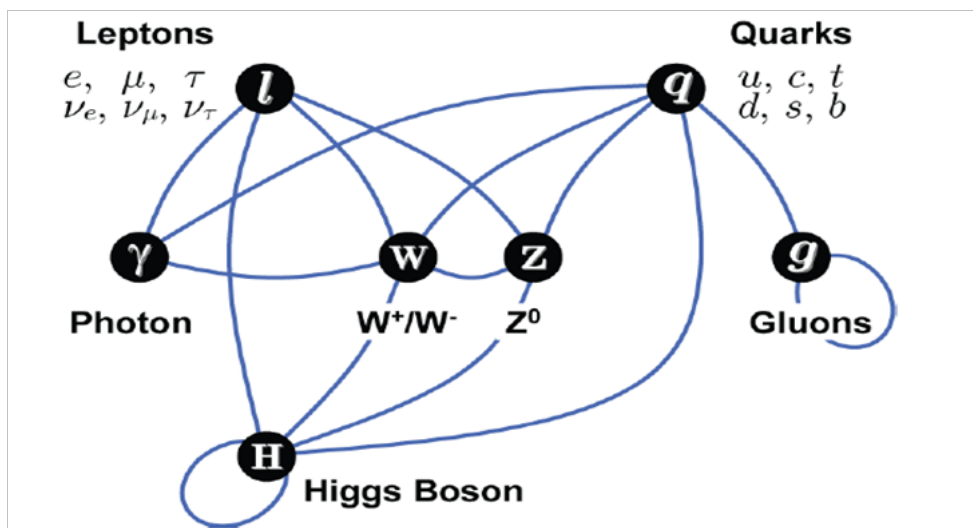

Fig.7. 5 Particles in magnetic field

- III. Explain why protons take a different path to that of the positrons.
6. A positron with kinetic energy 2.2 MeV and an electron at rest annihilate each other. Calculate the average energy of each of the two gamma photons produced as a result of this annihilation.
- C. Essay question**
7. Describe briefly the following particle-terms terms:  $\pi$  -meson, muon, neutrino, antiparticle, hadrons and lepton.

# UNIT 8

## PROPERTIES AND BASIC PRINCIPLES OF QUARKS



**Key unit competence:** Organize the properties and basic principles of quarks.

### My goals

- List types of quarks, identify quarks, antiquarks and hadrons (baryons and mesons)
- Define baryon number and state the law of conservation of baryon number.
- Interpret the baryon number and apply the law of conservation of baryon number
- State colors of quarks and gluons.
- Explain how color forms bound states of quarks.
- Formulate the spin structure of hadrons (baryon and mesons)

## INTRODUCTORY ACTIVITY

In the study of matter description and energy as well as their interactions; the fascinating thing of discovery is the structure of universe of infinite size but still there is a task to know the origin of matter. The smallest particle was defined to be electron, proton, and neutron. But one can ask:

1. What particles are components of matter?
2. Describe and discuss how particles interact with energy to form matter.

## 8.1 INTRODUCTION

### ACTIVITY 8.1: Investigating about elementary particles

Considering the knowledge and skills obtained from unit 8, about the study of elementary particles, discuss and explain the following questions:

1. Discuss the major groups of elementary particles
2. Explain and analyze the family of quarks and their interactions.
3. Why should we learn about elementary particles?

Particle physics is the field of natural science that pursues the ultimate structure of matter. This is possible in two ways. One is to look for elementary particles, the ultimate constituents of matter at their smallest scale, and the other is to clarify what interactions are acting among them to construct matter as we see them. The exploitable size of microscopic objects becomes smaller as technology develops. What was regarded as an elementary particle at one time is recognized as a structured object and relinquishes the title of “elementary particle” to more fundamental particles in the next era. This process has been repeated many times throughout the history of science (Nagashima, 2013).

In the 19<sup>th</sup> century, when modern atomic theory was established, the exploitable size of the microscopic object was and the atom was “the elementary particle”. Then it was recognized as a structured object when J.J. Thomson extracted electrons in 1897 from matter in the form of cathode rays. Its real structure (the Rutherford model) was clarified by investigating the scattering pattern of  $\alpha$ -particles striking a golden foil (See Fig 9.1).

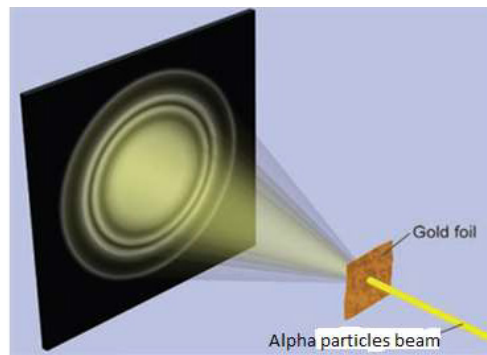

Fig 8.1: Scattering pattern of  $\alpha$ -particles striking a golden foil.

In 1932, Chadwick discovered that the nucleus, the core of the atom, consisted of protons and neutrons. In the same year, Lawrence constructed the first cyclotron. In 1934 Fermi proposed a theory of weak interactions. In 1935 Yukawa proposed the **meson** theory to explain the nuclear force acting among them.

It is probably fair to say that the modern history of elementary particles began around this time. The protons and neutrons together with their companion pions, which are collectively called hadrons, were considered as elementary particles until 1960. We now know that they are composed of more fundamental particles, the quarks. Electrons remain elementary to this day. Muons and  $\tau$ -leptons, which were found later, are nothing but heavy electrons, as far as the present technology can tell, and they are collectively dubbed leptons. Quarks and leptons are the fundamental building blocks of matter. The microscopic size that can be explored by modern technology is nearing  $10^{-19} m$ . The quarks and leptons are elementary at this level (Nagashima, 2013). Some composite particles as stated by (Hirsch, 2002) are summarized in the tables below

### 8.1. Checking my progress

1. Each hadron consists of a proper combination of a few elementary components called
  - a. Photons.
  - b. Vector bosons.
  - c. Quarks.
  - d. Meson-baryon pairs.
2. Which of the following is not conserved in a nuclear reaction?
  - a. Nucleon number.
  - b. Baryon number.
  - c. Charge
  - d. All of the above are conserved.
3. The first antiparticle found was the
  - a. Positron.
  - b. Hyperon.
  - c. Quark.
  - d. Baryon.

4. The proton, neutron, electron, and the photon are called
  - a. Secondary particles.
  - b. Fundamental particles.
  - c. Basic particles.
  - d. Initial particles.
5. The exchange particle of the electromagnetic force is the
  - a. Gluon.
  - b. Muon.
  - c. Proton.
  - d. Photon.
6. Particles that are bound by the strong force are called
  - a. leptons.
  - b. hadrons.
  - c. muons.
  - d. electrons.
7. At the present time, the elementary particles are considered to be the
  - a. Photons and baryons.
  - b. Leptons, quarks and bosons
  - c. Baryons and quarks.
  - d. Baryons and leptons.
8. The electron and muon are both
  - a. Jadrans.
  - b. Leptons.
  - c. Baryons.
  - d. Mesons.
9. Particles that make up the family of hadrons are
  - a. Baryons and mesons.
  - b. Leptons and baryons.
  - c. Protons and electrons.
  - d. Muons and leptons.
10. Is it possible for a particle to be both:
  - a. A lepton and a baryon?
  - b. A baryon and hadron?
  - c. A meson and a quark?
  - d. A hadron and a lepton?
11. Distinguish between
  - a. fermions and bosons
  - b. leptons and hadrons
  - c. mesons and baryon number
12. Which of the four interactions (strong, electromagnetic, weak, gravitational) does an electron, neutrino, proton take part in?

## 8.2 TYPES OF QUARKS

### ACTIVITY 9.2: Investigating Quark particles

Use search internet and find the explanation about quarks and types of quarks

**Quark** is a type of elementary particle and a fundamental constituent of matter. Quarks combine to form composite particles called **hadrons**, the most stable of which are **protons** and **neutrons**, the components of atomic nuclei. Due to a phenomenon known as **color confinement**, quarks are never directly observed or found in isolation; they can be found only within hadrons, such as **baryons** (of which protons and neutrons are examples) and **mesons**. For this reason, much of what is known about quarks has been drawn from observations of the hadrons themselves (Douglass, PHYSICS, Principles with applications., 2014).

Quarks have various intrinsic properties, including **electric charge**, **mass**, **color charge**, and **spin**. Quarks are the only elementary particles in the Standard Model of particle physics to experience all four fundamental interactions, also known as *fundamental forces* (electromagnetism, gravitation, strong interaction, and weak interaction (see section 8.5), as well as the only known particles whose electric charges are not integer multiples of the elementary charge. There are six types of quarks, known as **flavors**: **up**, **down**, **strange**, **charm**, **top**, and **bottom** (see Fig. 8.2). Up and down quarks have the lowest masses of all quarks.

The heavier quarks rapidly change into up and down quarks through a process of **particle decay** (the transformation from a higher mass state to a lower mass state). Because of this, up and down quarks are generally stable and the most common in the universe, whereas strange, charm, bottom, and top quarks can only be produced in high energy collisions (such as those involving cosmic rays and in particle accelerators). For every quark flavor there is a corresponding type of **antiparticle**, known as an antiquark, that differs from the quark only in that some of its properties have equal magnitude but opposite sign (Nagashima, 2013).

**Three Generations of Matter (Fermions)**

	I	II	III	
mass→	2.4 MeV	1.27 GeV	171.2 GeV	0
charge→	$\frac{2}{3}$	$\frac{2}{3}$	$\frac{2}{3}$	0
spin→	$\frac{1}{2}$	$\frac{1}{2}$	$\frac{1}{2}$	1
name→	<b>u</b> up	<b>c</b> charm	<b>t</b> top	<b><math>\gamma</math></b> photon
Quarks	4.8 MeV $-\frac{1}{3}$ $\frac{1}{2}$ <b>d</b> down	104 MeV $-\frac{1}{3}$ $\frac{1}{2}$ <b>s</b> strange	4.2 GeV $-\frac{1}{3}$ $\frac{1}{2}$ <b>b</b> bottom	0 0 1 <b>g</b> gluon
	<2.2 eV 0 $\frac{1}{2}$ <b><math>\nu_e</math></b> electron neutrino	<0.17 MeV 0 $\frac{1}{2}$ <b><math>\nu_\mu</math></b> muon neutrino	<15.5 MeV 0 $\frac{1}{2}$ <b><math>\nu_\tau</math></b> tau neutrino	91.2 GeV 0 1 <b>Z</b> weak force
	0.511 MeV -1 $\frac{1}{2}$ <b>e</b> electron	105.7 MeV -1 $\frac{1}{2}$ <b><math>\mu</math></b> muon	1.777 GeV -1 $\frac{1}{2}$ <b><math>\tau</math></b> tau	80.4 GeV $\pm 1$ 1 <b>W</b> weak force
Leptons				Bosons (Forces)

Fig.8. 2 Types of quarks

### 8.2.1 Checking my progress

1. A proton is made up of
  - a. One up quark and two down quarks
  - b. An up quark and down antiquark
  - c. Two up quarks and a down quark
  - d. Strange quark and an anti-strange quark
2. Particles that are unaffected by strong nuclear force are
  - a. Protons
  - b. Leptons
  - c. Neutrons
  - d. Bosons
3. Particle which explains about mass of matter is called
  - a. Higgs boson
  - b. Protons
  - c. Leptons
  - d. Neutrons
4. Describe the types and the characteristics of the quarks as well as their interaction properties.

## 8.3 BARYON NUMBER, LEPTON NUMBER AND THEIR LAWS OF CONSERVATION

### ACTIVITY 8.3: Investigating about particle numbers

Use search internet and retrieve the meaning of the following property of elementary particles.

- Baryon numbers and
- Lepton numbers

One of the important uses of high energy accelerators is to study the interactions of elementary particles with each other. As a means of ordering this sub-nuclear world, the conservation laws are indispensable. The law of conservation of energy, of momentum, of angular momentum, and of electric charge is found to hold precisely in all particle interactions.

A study of particle interactions has revealed a number of new conservation laws which (just like the old ones) are ordering principles. They help to explain why some reactions occur and others do not. For example, the following reactions have never been found to occur:

$$p + n \rightarrow p + p + \bar{p} \quad (8.01)$$

Even though charge, energy, and so on are conserved ( $\bar{p}$  means an antiproton and

⇒ means the reaction does not occur). To understand why such a reaction does not occur, physicists hypothesized a new conservation law, the **conservation of baryon number**.

Thus the law of conservation of baryon number states that: *“Whenever a nuclear reaction or decay occurs, the sum of baryon numbers before the process must equal the sum of the baryon numbers after the process.”*

**Baryon number** is a generalization of nucleon number, which is conserved in nuclear reaction and decays. All nucleons are defined to have baryon number  $B = +1$ , and all antinucleons (antiprotons, antineutrons) have  $B = -1$ . All other types of particles, such as photons, mesons, and electrons and other leptons have  $B = 0$ .

The reaction (9.01) shown above does not conserve baryon number since the left side  $B = +1 + 1 = +2$ , and the right-hand side has  $B = +1 + 1 - 1 = +1$ . On the other hand, the following reaction does conserve  $B$  and does occur if the incoming proton has sufficient energy



$$B = +1 + 1 = +1 + 1 - 1 + 1 = +2$$

As indicated,  $B = +2$  on both sides of this equation. From these and other reactions, the conservation of baryon number has been established as basic principle of physics.

Also useful are the conservation laws of the three **lepton numbers**, associated with weak interactions including decays, in ordinary  $\beta$  decay, an electron or positron is emitted along with a neutrino or antineutrino. In a similar type of decay, a particle known as  $\mu$  or mu meson, or **muon**, can be emitted instead of an electron. The muon seems to be much like an electron, except its mass is 207 times larger ( $106 \text{ MeV} / c^2$ ). The neutrino  $\nu_e$  that accompanies an emitted electron is found to be different from the neutrino  $\nu_\mu$  that accompanies an emitted muon. Each of these neutrinos has an antiparticle  $\bar{\nu}_e$  and  $\bar{\nu}_\mu$ .

The law of conservation of electron-lepton number states that: *“The sum of the electron-lepton numbers before reaction or decay must equal the sum of the electron-lepton numbers after the reaction or decay.”*

In ordinary  $\beta$  decay we have for example,, a second quantum number, muon

lepton number, is conserved. The and are assigned and and havewhereas other particles have, too is conserved in interaction and decays. Similarly assignment can be made for the tau lepton number associated with the Lepton and its neutrino,

Keep in mind that antiparticles have not only opposite electric charge from their particles, but also opposite  $B$ ,  $L_e$ ,  $L_\mu$  and  $L_\tau$ .

For example, neutrino has  $B = 1$ , an antineutrion has  $B = -1$  while all the  $L$ 's are zero.

### EXAMPLE 8.1

1. Which of the following decay is possible for muon decay:

- a.  $\bar{\mu} \rightarrow e^- + \bar{\nu}$
- b.  $\bar{\mu} \rightarrow e^- + \nu_\mu$
- c.  $\bar{\mu} \rightarrow e^- + \nu_e$

These particles have  $L_\tau = 0$

**Answer:**

$A\bar{\mu}$  has  $L_\mu = +1$  and  $L_e = 0$ . This is the initial state, and the final state (after decay) must also have  $L_\mu = +1$ ,  $L_e = 0$

- a. The final state has  $L_\mu = 0 + 0 = 0$  and  $L_e = +1 - 1 = 0$  would not be conserved and indeed this decay is not observed to occur.
- b. The final state of reaction has  $L_\mu = 0 + 0 + 1 = +1 = 0$  and  $L_e = +1 - 1 + 0 = 0$  so both  $L_\mu$  and  $L_e$  are conserved. This is in fact the most common decay mode of the  $\bar{\mu}$ .
- c. The reaction does not occur because  $L_e = 2$  in the final state is not conserved, nor  $L_\mu$

The particle predicted by Yukawa was discovered in cosmic rays by C.F Powell and G. Ochialini in 1947, and is called the  $\pi$  or pi meson, or simple called **pion**.

It comes in three states: +, - or 0.. The  $\pi^+$  and  $\pi^-$  have mass of  $139.6 \text{ MeV}/c^2$  and the  $\pi^0$  has a mass of  $135.0 \text{ MeV}/c^2$ , all close to Yukawa's prediction (Douglass, PHYSICS, Principles with applications., 2014). All three interact strongly with matter.

**Reactions** observed in the laboratory, using a particle accelerator, include:

$$p + p \rightarrow p + p + \pi^0 \quad (8.03)$$

$$p + p \rightarrow p + n + \pi^- \quad (8.04)$$

The incident proton from the accelerator must have sufficient energy to produce the additional mass of the free pion. Baryon number conservation keeps the proton stable, since it forbids the decay of the proton to e.g. a  $\pi^0$  and a  $\pi^+$  each of which have baryon number of zero.

### 8.3.1 Checking my progress

1. Discuss and explain the law of conservation of baryon numbers and give an example.
2. Discuss whether the following reaction obeys the conservation of baryon number:

- a.  $p + p \rightarrow p + \bar{p} + n + \pi^-$
- b.  $p + p \rightarrow p + n + \pi^+$

## 8.4 SPIN STRUCTURES OF HADRONS (HADRONS AND MESONS)

### ACTIVITY 8.4: Investigating the structure of elementary particles

1. Use search internet and find the structure of elementary particles: Hadrons and mesons.
2. Discuss and explain your findings in a brief summary about structure of hadrons.

There are hundreds of hadrons, on the other hand, and experiments indicate they do have an internal structure. In 1963, M. Gell-Mann and G. Zweig proposed that none of the hadrons, not even the proton and neutron, are more fundamental, point like entities called, somewhat whimsically, **quarks**. Today, the quark theory is well accepted, and quarks are considered the truly elementary particles, like leptons. The three quarks originally proposed we

labeled **u, d, s** and have the names up, down and strange. The theory today has six quarks, just as there are six leptons based on presumed symmetry in nature,

The other three quarks are called charmed, bottom and top (see Fig.8.2). The theory names apply also to new properties of each (quantum numbers c, t, b) that distinguish the new quarks from the old quarks (see Table 9.1 below), and which (like strangeness) are conserved in strong, but not weak, interactions.

All quarks have spin  $\frac{1}{2}$  and an electric charge of either  $\frac{2}{3}e$  or  $-\frac{1}{3}e$  (that is, a fraction of the previously thought smallest charge  $e$ ). Antiquarks have opposite sign of electric charge  $Q$ , baryon number  $B$ , strangeness  $S$ , charm  $c$ , bottomness  $b$ , and topness  $t$ .

Quarks							
Name	Symbol	Charge Q	Baryon number B	Strange ness S	Charm c	Bottomness b	Topness T
Up	U	$+\frac{2}{3}e$	$\frac{1}{3}$	0	0	0	0
Down	D	$-\frac{1}{3}e$	$\frac{1}{3}$	0	0	0	0
Strange	S	$-\frac{1}{3}e$	$\frac{1}{3}$	-1	0	0	0
Charmed	C	$+\frac{2}{3}e$	$\frac{1}{3}$	0	+1	0	0
Bottom	B	$-\frac{1}{3}e$	$\frac{1}{3}$	0	0	-1	0
Top	T	$+\frac{2}{3}e$	$\frac{1}{3}$	0	0	0	+1

Table 8. 1

Table 8. 1 Properties of Quarks (Antiquarks have opposite sign Q, B, S, c, b and t. All hadrons are considered to be made up of combinations of quarks, and their properties are described by looking at their quark content. Mesons consist of quark-antiquark pair (See Table 8.2).

For example, a  $\pi^+$  meson is a  $u\bar{d}$  combination: note that for the  $u\bar{d}$  pair,

$$Q = \frac{2}{3}e + \frac{1}{3}e + 1e$$

$$B = \frac{1}{3} - \frac{1}{3} = 0$$

$$S = 0 + 0 = 0$$

as they must for a  $\pi^+$ ; and a  $K^+ = u\bar{s}$ , with  $Q = +1$ ,  $B = 0$ ,  $S = +1$ .

Baryons, on other hand, consist of three quarks. For example, a neutron is  $n = ddu$ , whereas an antiproton  $\bar{p} = \bar{u}\bar{u}\bar{d}$  (see Table 8.3). Strange particles all contain an s or  $\bar{s}$  quark, whereas charmed particles contain a c or  $\bar{c}$  quarks. From Table 8.2 and Table 8.3, you will find that:

**Meson = quark + antiquark**

**Baryon = 3 quarks**

Some examples of mesons, with their quark compositions and the corresponding values of their electric charge Q, strangeness S, charm C and bottom  $\tilde{B}$

Particle		Q	S	C	$\tilde{B}$
$\pi^+$	$u\bar{d}$	1	0	0	0
$K^-$	$s\bar{u}$	-1	-1	0	0
$D^-$	$d\bar{c}$	-1	0	-1	0
$D^+$	$c\bar{s}$	1	1	1	0
$B^-$	$b\bar{u}$	-1	0	0	-1
$\Gamma$	$b\bar{b}$	0	0	0	0

Table 8.2 Properties of some mesons

Some of examples of baryons, with their quark compositions and the corresponding values of their electric charge Q, Strangeness S, charm C and bottom  $\tilde{B}$

Particle		Q	S	C	$\tilde{B}$
<b>p</b>	<b>uud</b>	<b>1</b>	<b>0</b>	<b>0</b>	<b>0</b>
<b>n</b>	<b>udd</b>	<b>0</b>	<b>0</b>	<b>0</b>	<b>0</b>
$\Lambda$	$uds$	0	-1	0	0
$\Lambda_c$	$udc$	1	0	1	0
$\Lambda_b$	$udb$	0	0	0	-1

Table 8.3 Properties of some baryons

After the quark theory was proposed, physicists began looking for those fractionally charged particles, but direct detection has not been successful. Current models suggest that quarks may be so tightly bound together that they may not ever exist singly in the free State. But observations of very high energy electrons scattered off protons suggest that protons are indeed made up of constituents.

Today, the truly elementary particles are considered to be the six quarks, the six leptons and the gauge bosons that carry the fundamental forces. See Table 9.4 where the quarks and leptons are arranged in three “generations.” Ordinary matter-atoms made of protons, neutrons, and electrons are contained in the “first generation”. The others are thought to have existed in the very early universe, but are seen by us today at powerful accelerators or in cosmic rays. All of the hundreds of hadrons can be accounted for by combinations of the six quarks and six antiquarks.

Gauge bosons	Force		First generation	Second generation	Third generation
Gluons	Strong	Quarks	$u, d$	$s, c$	$b, t$
$W^\pm, Z_0$	Weak	Leptons	$e, \nu_e$	$\mu, \nu_\mu$	$\tau, \nu_\tau$
$\gamma$ (photon)	EM				

Table 8.4 The Elementary Particles as seen nowadays

Note that the quarks and leptons are arranged into three generations each.

### EXAMPLE 8.1

1. Find the baryon number, charge, and strangeness for the following quark combinations, and identify the hadrons particle that is made up of these quark combinations: a.  $udd$ , b.  $u\bar{u}$ , c.  $uss$ , d.  $sdd$  and e.  $b\bar{u}$

**Answer:**

We use Table 8.1, Table 8.2 and Table 8.3 to get the properties of the quarks, then to find the particle that has these properties.

$$\text{a. } udd \text{ has } Q = +\frac{2}{3}e - \frac{1}{3}e = 0, \quad B = +\frac{1}{3} + \frac{1}{3} + \frac{1}{3} = 1, \quad S = 0 + 0 + 0 = 0,$$

as well as  $c = 0$ , bottomness = 0 and topness = 0.

The only baryon (baryonic number =+1) with  $Q=0$ ,  $S=0$  etc, is the neutron (Table 8.3)

- b.  $u\bar{u}$  has  $Q = + - e - - e = 0$ ,  $B = 0$  and all other quantum numbers = 0. It sounds like a  $\pi^0$  ( $d\bar{d}$  also gives a  $\pi^0$  and we say a  $\pi^0$  is  $u\bar{u} + d\bar{d}$ ).
- c.  $uss$  has  $Q = 0$ ,  $B = +1$ ,  $S = -2$ , others = 0. This is  $\Sigma^0$ .
- d.  $sdd$  has  $Q = -1$ ,  $B = +1$ ,  $S = -1$ , so must be a  $\Sigma^-$
- e.  $b\bar{u}$  has  $Q = -1$ ,  $B = 0$ ,  $S = 0$ ,  $C = 0$ , bottomness = -1 and topness = 0. This must be a  $B^-$  meson.

### 8.4.1 Checking my progress

1. Identify the particle corresponding to each of the following quark combinations:
  - a.  $\bar{s}\bar{u}s\bar{u}$
  - b.  $\bar{d}\bar{u}d\bar{u}$
  - c.  $udsuds$
  - d.  $uusuus$
2. The  $B^-$  meson is  $b\bar{u}$  quark combination.
  - a. Show that this is consistent for all quantum numbers
  - b. What are the quark combinations for?  $B^+$ ,  $B^0$ ,  $B^0$
3. What are the quark combination that can form:
  - a. A neutron
  - b. An antineutron
  - c.  $\Lambda^0$
  - d.  $\bar{\Lambda}^0$

## 8.5 COLOR IN FORMING OF BOUND STATES OF QUARKS.

### ACTIVITY 8.5: Investigating the bound state of an atom

Take the case of an electronic configuration of hydrogen atom. Make the illustration and then contrast the interaction between electron and proton and bound state of elementary particles.

### 8.5.1 Bound state of quarks

In the hydrogen atom configuration, the proton is located at centre while electron moves around it at a speed of about 1% the speed of light. The proton is heavy while the electron is light (See Fig.8.3)

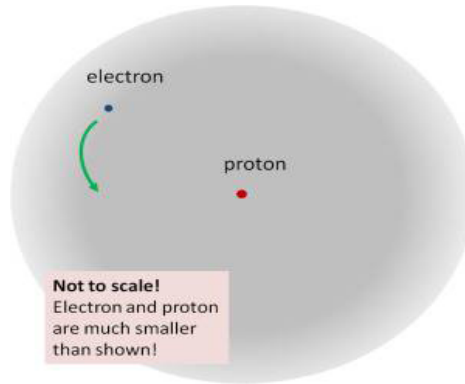

Fig.8. 3 The structure of Hydrogen atom (Strassler, 2011)

This is the simplest example of what physicists call a **“bound state”**. The word **“state”** basically just meaning a thing that hangs around for a while, and the word **“bound”** meaning that it has components that are bound to each other, **as spouses are bound in marriage**.

The inside of the proton itself is more like a commune packed full of single adults and children: **pure chaos**. It too is a **bound state**, but what it binds is not something as simple as a proton and an electron, as in hydrogen, or even a few dozen electrons to an atomic nucleus, as in more complicated atoms such as gold, but zillions (*meaning “too many and too changeable to count usefully”*) of lightweight particles called quarks, antiquarks and gluons. It is impossible to describe the proton’s structure simply, or draw simple pictures, because it’s highly disorganized. All the quarks and antiquarks and gluons (see Fig.8.4) inside are rushing around as fast as possible, at nearly the speed of light (Strassler, 2011).

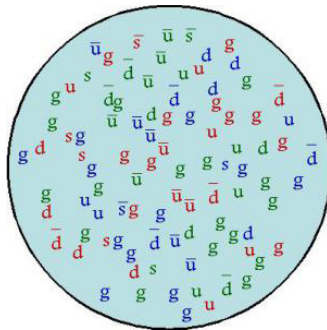

Fig.8. 4

Fig.8. 4 Snapshot of a proton: Imagine all of the quarks (up, down, and strange: u, d, s), antiquarks (u, d, s with a bar on top), and gluons (g) zipping around near the speed of light, banging into each other, and appearing and disappearing (Strassler, 2011). You may have heard that a proton is made from three quarks but this is not true. In fact there are billions of gluons, antiquarks, and quarks in a proton.

### 8.5.2 Color in forming of bound states of quarks.

In the standard model of Quantum Chromodynamics (QCD) and the electroweak theory (Giancoli D. C., Physics: principals with application, 2005), not long after the quark theory was proposed, it was suggested that quarks have another property (or quality) called **color, or 'color charge'** (analogous to electric charge). The distinction between the six quarks (u, d, s, c, b, t) was referred to as **flavors**.

According to the theory, each of the flavors of quark can have **three colors**, usually designated **red, green and blue**. These are the three primary colors which, when added together in equal amounts, as on a TV screen, produce white. Note that the names 'color' and 'flavor' have nothing to do with our sense, but are purely whimsical as are other names, such as charm, in this new field. The antiquarks are colored antired, antigreen and antiblue. Baryons are made up of three quarks, one of each color. Mesons consist of quark-antiquark pair of a particular color and its anticolor. Both baryons and mesons are thus colorless or white.

Originally, the idea of quark color was proposed to preserve the **Pauli exclusion principle**. Not all particles obey the exclusion principle. Those that do, such as electrons, protons and neutrons, are called **fermions**. Those that don't are called **bosons**. These two categories are distinguished also in their spin: bosons have integer spin (0, 1, etc) whereas fermions have half-integer spin, usually  $\frac{1}{2}$  as for electrons and nucleons, but other fermions have spin  $\frac{3}{2}, \frac{5}{2}$  etc.

Matter is made up mainly of fermions, but the carriers of forces ( $\gamma, W, Z$  and

gluons) are all bosons. Quarks are fermions they have spin  $\frac{1}{2}$  and therefore should obey the exclusion principle. Yet for three particular baryons (uuu, ddd, and sss), all three quarks would have the same quantum numbers, and at least two quarks have their spin in the same quantum numbers, and at least two quarks have their spin in the same direction (since there are only two choices,

spin up ( $m_s = +\frac{1}{2}$ ) or spin down ( $m_s = -\frac{1}{2}$ ).

This would seem to violate the exclusion principle; but if quarks have an additional quantum number (color), which is different for each quark, it would serve to distinguish them and allow the exclusion principle to hold. Although quark color, and the resulting threefold increase in the number of quarks, was originally an *ad hoc* idea, it also served to bring the theory into better agreement with experiment, such as predicting the correct lifetime of the  $\pi^0$  meson. The idea of color soon became a central feature of the theory as determining the force binding quarks together in hadron.

### 8.5.3 Colour as component of quarks and gluons

#### ACTIVITY 8.6: Investigating the origin of color

When a metal like iron is heated red-hot, one can observe the change in color. As the energy increases, as the color changes. Use the same experiment and discuss on the following questions

1. As the color changes in the metal, what are the scientific reasons behind that?
2. Explain the matter — energy interaction and their consequences
3. What is color in the field of elementary particles?

The attractive interactions among quarks are mediated by massless spin  $-1$  bosons called gluons in much the same way that photons mediate the electromagnetic interaction or that pions mediated the nucleon–nucleon force in the old Yukawa theory (Nagashima, 2013).

#### Particles were classified into two categories:

Quarks and leptons have an intrinsic angular momentum called spin, equal to a half-integer ( $\frac{1}{2}$ ) of the basic unit and are labeled as fermions. Fermions obey the exclusion principle on which the Fermi-Dirac distribution function is based. This would seem to forbid a baryon having two or three quarks with the same flavor and same spin component. To avoid this difficulty, it is assumed that each quark comes in three varieties, which are called color: red, green, and blue. The exclusion principle applies separately to each color. Particles that have zero or integer spin are called bosons. Bosons do not obey the exclusion principle and have a different distribution function, the Bose-Einstein distribution.

- A baryon always contains one red, one green, and one blue quark, so the baryon itself has no net color.
- Each gluon has a color–anticolor combination (for example, blue–antired) that allows it to transmit color when exchanged, and color is conserved during emission and absorption of a gluon by a quark.
- The gluon-exchange process changes the colors of the quarks in such a way that there is always one quark of each color in every baryon. The color of an individual quark changes continually as gluons are exchanged.

**Similar processes occur in mesons such as pions:**

- The quark–antiquark pairs of mesons have canceling color and anticolor (for example, blue and antiblue), so mesons also have no net color. Suppose a pion initially consists of a blue quark and an antiblue antiquark.
- The blue quark can become a red quark by emitting a blue–antired virtual gluon.

The gluon is then absorbed by the antiblue antiquark, converting it to an antired antiquark (Fig. 8.8). Color is conserved in each emission and absorption, but a blue–antiblue pair has become a red–antired pair. Such changes occur continually, so we have to think of a pion as a superposition of three quantum states:

- Blue–antiblue,
- Green–antigreen, and
- Red–antired.

In terms of quarks and gluons, these mediating virtual mesons are quark–antiquark systems bound together by the exchange of gluons.

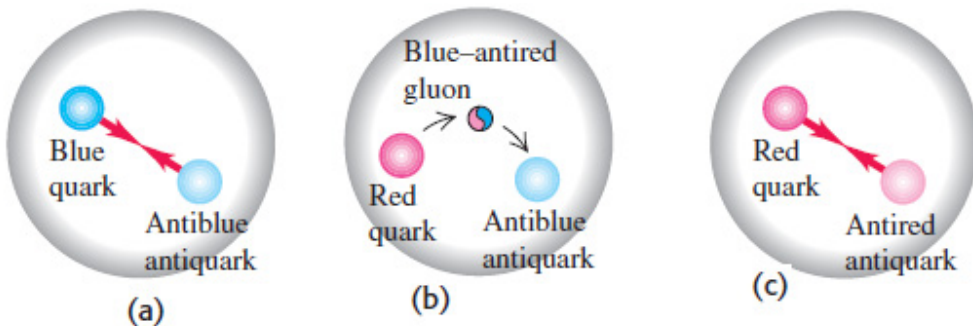

Fig.8 5

Fig.8. 5 (a) A pion containing a blue quark and an antiblue antiquark. (b) The blue quark emits a blue–antired gluon, changing to a red quark. (c) The gluon is absorbed by the antiblue antiquark, which becomes an antired antiquark. The pion now consists of a red–antired quark–antiquark pair. The actual quantum state of the pion is an equal superposition of red–antired, green–antigreen, and blue–antiblue pairs.

### 8.5.4 Checking my progress

1. Label the illustration below and analyze the interaction between its particles.

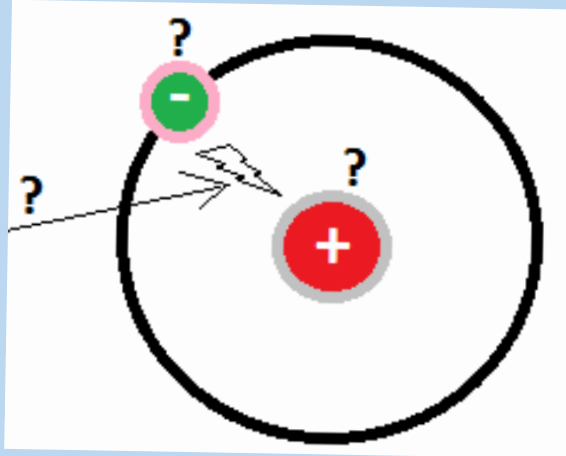

Fig.8. 6 Illustration diagram

Define and describe the following key concept:

- I. Color charge:
- II. Gluons
- III. Quantum chromodynamics

2. Which one of the following sets of color combinations is added in color vision in TV?

- |                             |                           |
|-----------------------------|---------------------------|
| a. Red, green and blue      | c. White, red and yellow  |
| b. Orange, black and violet | d. Yellow, green and blue |

3. What are the color composition of

- a. Gluons
- b. Meson
- c. Baryon

## END UNIT ASSESSMENT 8

### A. Multiple choices

1. A proton is made up of
  - a. One up quark and two down quarks
  - b. An up quark and down antiquark
  - c. Two up quarks and a down quark
  - d. Strange quark and an antistrange quark
2. Particles that are unaffected by strong nuclear force are
  - a. Protons
  - b. Teptons
  - c. Neutrons
  - d. Bosons
3. Particle which explains about mass of matter is called
  - a. Higgs boson
  - b. Leptons
  - c. Protons
  - d. Neutrons
4. A conservation law that is not universal but applies only to certain kinds of interactions is conservation of:
  - a. Lepton number
  - b. Baryon number
  - c. Spin
  - d. Charge
  - e. Strangeness
5. In quantum electrodynamics (QED), electromagnetic forces are mediated by
  - a. the interaction of electrons.
  - b. hadrons.
  - c. D. the weak nuclear interaction.
  - d. action at a distance.
  - e. E. the exchange of virtual photons.
6. Conservation laws that describe events involving the elementary particles include the conservation of energy.
  - a. All of these are correct.
  - b. electric charge.
  - c. baryon and lepton numbers.
  - d. linear and angular momentum.

7. The conservation law violated by the reaction  $p \rightarrow \pi^0 + e^+$  is the conservation of

- Charge.
- Energy.
- Linear momentum.
- Lepton number and baryon number.
- Angular momentum.

8. Particles that participate in the strong nuclear interaction are called

- Neutrinos
- Hadrons
- Leptons
- Electrons
- Photons

### B. Structured questions

9. In the table cross-word below, find at least fifteen names associated to elementary particles. Among them, select ones that represents quarks, leptons or radiations.

M	K	L	G	T	B	A	V	A	E	K	X	R	A	Y
E	N	A	T	H	A	N	A	S	L	J	Y	A	M	V
S	Q	U	A	R	K	Z	L	N	E	U	C	L	E	I
O	A	M	U	R	C	B	E	G	C	L	P	P	N	L
N	P	N	E	M	I	L	L	E	T	L	H	H	K	U
K	S	E	V	A	R	I	S	T	R	E	Y	O	A	N
X	I	M	B	E	T	A	K	A	O	N	S	N	B	G
R	C	A	G	L	A	S	P	I	N	Z	I	S	A	A
A	O	K	A	L	P	H	A	L	E	I	C	I	R	O
P	L	A	M	D	A	T	I	V	U	O	S	N	Y	S
R	O	Q	M	K	A	N	E	U	T	R	I	N	O	B
O	R	T	A	G	M	I	N	O	R	W	A	N	N	E
T	U	S	G	A	U	G	E	B	O	S	O	N	G	R
O	L	E	P	T	O	N	B	E	N	O	N	C	A	T
N	I	Y	D	O	N	A	T	P	A	T	R	I	C	K

10.a. Making massive particles: Relatively massive particles like the proton and neutron are made of combinations of three quarks.

- I. What is the charge on the combination  $uuu$ ?
- II. What is the charge on the combination  $uud$ ?
- III. What is the charge on the combination  $udd$ ?
- IV. What is the charge on the combination  $ddd$ ?

b. There are four compound particles here

- I. Which combination has the right charge to be a proton?
- II. Which combination has the right charge to be a neutron?
- III. There is a particle called the  $\Delta^-$  which has a charge of  $-1e$ . Which quark combination could be the  $\Delta^-$ ?
- IV. There is a particle called the  $\Delta^{++}$  which has a charge of  $+2e$ . Which quark combination could be the  $\Delta^{++}$ ?
- V. A neutron can be changed to a proton if one quark changes 'flavour'. What change is needed? What charge must be carried away if this happens?

c. Making mesons

Other, lighter 'middle-weight' particles called mesons can be made from pairs of quarks. But they have to be made from a special combination: a quark and an antiquark. There are now four particles to play with: Up quark  $u$ : charge  $+2/3 e$ , Down quark  $d$ : charge  $-1/3 e$ , Antiquark  $\bar{u}$ : charge  $-2/3 e$ . Antidown quark  $\bar{d}$ : charge  $+1/3 e$ .

11.

- I. What is the charge on the combination  $u\bar{u}$ ?
- II. What is the charge on the combination  $d\bar{d}$ ?
- III. What is the charge on the combination  $u\bar{d}$ ?
- IV. What is the charge on the combination  $d\bar{u}$ ?
- V. Which combination could be the  $\pi^+$  meson?
- VI. Which combination could be the  $\pi^-$  meson?
- VII. Which could be the neutral meson  $\pi^0$ ?

12. Identify the missing particle in the following reactions.

- a.  $p + p \rightarrow p + n + \pi^+ + ?$
- b.  $\pi^+ + p \rightarrow K^+ + \mu^+$

interaction could they occur? For those forbidden. Explain why.

- I.  $\pi^- + p \rightarrow K^+ + \Sigma^-$
- II.  $\pi^+ + p \rightarrow K^- + \Sigma^-$
- III.  $\pi^- + p \rightarrow \Lambda^0 + K^0 + \pi^0$
- IV.  $\pi^+ + p \rightarrow \Sigma^0 + \pi^0$
- V.  $\pi^- + p \rightarrow p + e^- + \bar{\nu}_e$

13. Determine which of the following reactions can occur. For those that cannot occur, determine the conservation law (or laws) violated.

- a.  $p \rightarrow \pi^+ + \pi^0$
- b.  $p + p \rightarrow p + p + \pi^0$
- c.  $p + p \rightarrow p + \pi^+$
- d.  $\pi^+ \rightarrow \mu^+ + \nu_\mu$
- e.  $n \rightarrow p + e^- + \bar{\nu}_e$
- f.  $n^+ \rightarrow \mu^+ + n$

# UNIT 9

## EFFECT OF X-RAYS



**Key unit competence:** BAnalyze and evaluate the effects of x-rays.

### My goals

- Explain the production of X-rays
- State the properties of X-rays.
- Explain the origin and characteristic features of an x-ray spectrum.
- Outline the applications of X-rays in medicine, industries, and scientific research
- Solve problems involving accelerating potential and minimum wavelength of X-rays.
- Recognize how the intensity and quality of X-rays can be controlled.
- Appreciate the use of X-rays in medicine and industry

## INTRODUCTORY ACTIVITY

When a person goes to the hospital with pain in her/his chest, or with an internal fracture of the bone, physicians do normally recommend the patient to pass by radiology service. Hence try to answer the following questions:

1. Why do physicians recommend patients to pass by radiology service?
2. Radiology means that there are radiations. Discuss different types of radiations that are found in there?
3. Discuss the production of X-ray radiations.
4. What are the positive and negative effects of X-ray radiation on the human body?

## 9.1 PRODUCTION OF X-RAYS AND THEIR PROPERTIES

### ACTIVITY 9.1: Investigating the production of X-rays

Read the following text and answer the questions that follow.

**Discovery of X-rays:** Becquerel's discovery wasn't the only important accidental one. In the previous year W.C. Roentgen unexpectedly discovered X-rays while studying the behavior of electrons in a high-voltage vacuum tube. In that instance, a nearby material was made to fluoresce. Roentgen named them X-rays because he didn't know what they were.

Within twenty years of this discovery, diffraction patterns produced using X-rays on crystal structures had begun to show the finer structure of crystals while, at the same time, giving evidence that X-rays had a wave nature. Since then, X-ray radiation has become an indispensable imaging tool in medical science.

#### Questions:

1. What do you understand by X-rays?
2. How are X-rays produced?
3. Where are X-rays used?

### 9.1.1 X-ray production

X-rays are produced when fast moving electrons strike matter (see Fig.9.1). They were first produced in 1895 by Wilhelm Rontgen (1845-1923), using an apparatus similar in principle to the setup shown in Fig.9.1.

Electrons are emitted from the heated cathode by thermionic emission and are accelerated toward the anode (the target) by a large potential difference  $V$ . The bulb is evacuated (residual pressure  $10^{-7}$  atm or less), so that the electrons can travel from the cathode to the anode without colliding with air molecules. It was observed that when  $V$  is a few thousands volts or more, a very penetrating radiation is emitted from the anode surface.

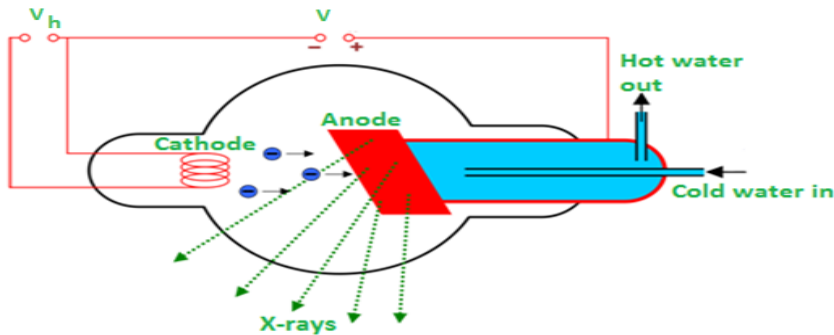

Fig.9.1: The Coolidge tube, also called hot cathode tube or X-ray tube.

The above figure is an illustration of the Coolidge tube which is the most widely used device for the production of X-rays. The electrons are produced by thermionic effect from filament, which is the cathode of the tube, heated by an electric current. These electrons are accelerated towards a metal target that is the anode due to the high potential voltage between the cathode and the anode.

The target metals are normally Tungsten or Molybdenum and are chosen because they have high melting point and higher atomic weights. The accelerated electrons interact with both electrons and nuclei of atoms in the target and a mysterious radiation is emitted. This radiation was referred to as X-rays. About 98% of the energy of the incident electron is converted into heat that is evacuated by the cooling system and the remaining 2% come out as X-rays.

### 9.1.2 Types of X-rays

Sometimes X-rays are classified according to their penetrating power. Two types are mentioned:

- **Hard X-rays:** those are X-rays on upper range of frequencies or shorter wavelength. They have greater energy and so they are more penetrating.
- **Soft X-rays:** they are X-rays on lower range of frequencies or longer wavelength. They have lower energy and they have very low penetrating power. The Fig.9.2 below shows the relative location of the different types of X-rays.

Hard X-rays are produced by high accelerating potential. They have high penetrating power and short wavelength while soft X-rays are produced by lower accelerating potential, have relatively low penetrating power and relatively long wavelength.

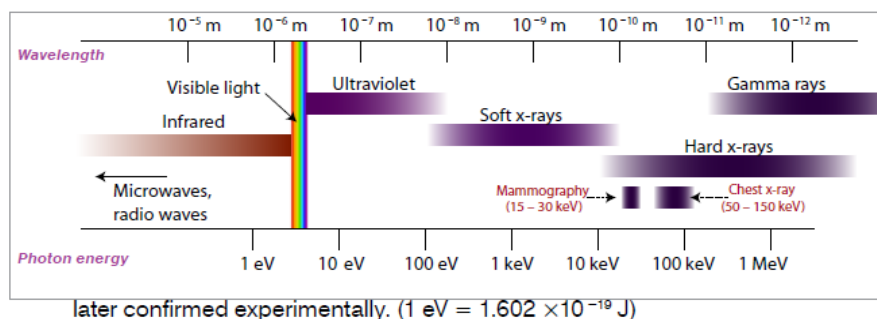

Fig.9. 2: The location of x-ray in the electromagnetic spectrum.

### 9.1.3 Properties of X-rays

#### ACTIVITY 9.2: Understanding the pros and cons of X-rays

Make intensive research on the production and the properties of X-rays, then write a report about your findings.

The following are the main properties of X-rays:

- X-rays can penetrate through most substances. However, their penetrating power is different.
- X-ray can produce fluorescence in different substances.
- X-rays can blacken photographic plate. The degree of blackening depends upon the intensity of x-rays incident upon the plate. Thus, X-ray intensity can be measured with the help of photographic plates.
- X-rays ionize the gas through which they travel. The ionizing power depends on the intensity of the x-ray beam. Thus, X-ray intensity can also be measured by measuring their ionizing power.
- X-rays are not deflected by electric or magnetic fields. This proves that unlike cathode rays or positive rays they are not a beam of charged particles.
- X-rays travels on a straight lines like ordinary light.
- X-ray are both reflected and refracted.
- X-rays can be diffracted with the help of crystalline substances. They can also be polarized.

From the above characteristics it can be seen that X-rays have the properties that are common to all electromagnetic radiations.

### 9.1.4 Checking my progress

1. Describe the process by which X-rays are produced.
2. Discuss and describe the types of X-rays?
3. What is the meaning of the X in X-ray?
4. How are X-rays different from other electromagnetic radiations?

## 9.2 THE ORIGINS AND CHARACTERISTIC FEATURES OF AN X-RAY SPECTRUM

### ACTIVITY 9.3: investigating the X-ray spectrum

During the production of X-rays, a high voltage must be applied across the x rays tube to produce enough acceleration of electrons towards the target.

Search internet, then discuss and explain the relationship between the applied

### 9.2.1 Variation of the X-ray intensity with wavelength

Depending on the accelerating voltage and the target element, we may find sharp peaks superimposed on a continuous spectrum as indicated on Fig.9.3. These peaks are at different wavelengths for different elements; they form what is called a *characteristic x-ray spectrum* for each target element.

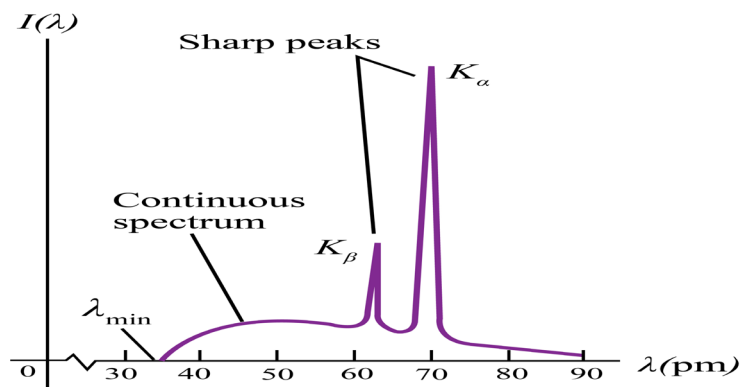

Fig.9.3: Intensity as a function of the wavelength of x-rays emitted at a particular voltage.

X-rays of different wavelengths are emitted from X-ray tube. If the intensity is measured as a function of the wavelength and the variation is plotted graphically

then a graph of the nature shown on the figure above is obtained. The graph has the following features:

- Minimum wavelength
- Continuous spectrum
- Characteristic peaks

### 9.2.2 Origin of the continuous spectrum

It is known that when charged particles such as electrons are accelerated or decelerated they emit electromagnetic radiation of different frequencies. In doing so a part of their kinetic energy is transformed in the energy of the emitted radiation. Electrons inside the x-ray tube decelerate upon hitting the target and as a result they emit electromagnetic radiations with a continuous distribution of wavelength starting from a certain minimum wavelength. This mechanism of producing electromagnetic radiation from an accelerated or decelerated electron is called **bremstrahlung**.

The energy of the emitted photon is given by

$$E = hf = \frac{hc}{\lambda} \quad (10.01)$$

where  $h = 6.6260 \times 10^{-34} \text{ j.s}$  is the Planck constant and  $c = 3.0 \times 10^8 \text{ m/s}$  the speed of light in vacuum.

The maximum energy of the emitted photons is therefore equal to the energy of the incident electron:

$$E = eV = \frac{hc}{\lambda_{\min}} \quad (10.02)$$

Where  $\lambda_{\min}$  is the minimum wavelength, V is the potential difference between anode and cathode and e the charge of the electron.

If V is measured in volts we get

$$\lambda_{\min} = \frac{12413}{V} \text{ A}^{\circ} \quad (10.03)$$

Thus if  $V = 1000 \text{ volts}$  then  $\lambda_{\min} = 1.24 \text{ A}^{\circ}$  and if  $V = 5000 \text{ volts}$  then  $\lambda_{\min} = 0.248 \text{ A}^{\circ}$

As the many electrons in the X-ray are decelerated differently, this will result in a continuous spectrum of the emitted wavelengths.

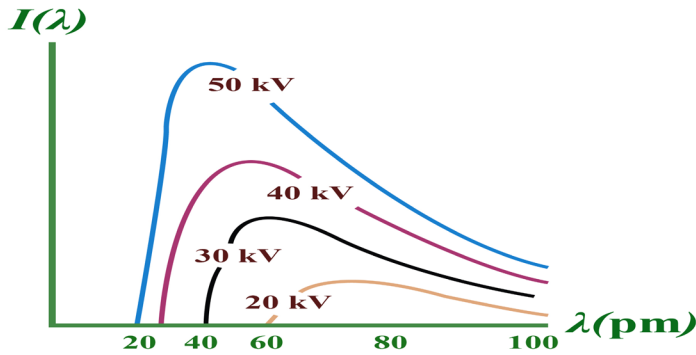

Fig.9.4: Intensity as a function of the wavelength of x-rays emitted at a particular voltage.

It can be observed from the above Fig.9.4 that, for different values of the accelerating voltage, the minimum wavelength decreases with increasing potential difference and for a given wavelength the intensity is higher when the potential difference is higher.

### 9.2.3 Origin of characteristic lines

The peaks observed in wavelengths distribution curves as shown in Fig. 9.4 are spectral lines in the X-ray region. Their origin lies in the transition between energy levels in the atoms of the target. The electrons in the atoms are arranged in different atomic shell. Of these, the first two electrons occupy the K-shell followed by 8 electrons in the L-shell, 18 electrons in the M-shell and so on until the electron in the target are used up. A highly accelerated electron may penetrate atom in the target and collide with an electron in K-shell. If such electron is knocked out it will leave an empty space that is immediately filled up by another electron probably from the L-shell or M-shell. This transition will be accompanied by the emission of the excess energy as a photon.

The energy of the emitted photon is a characteristic of the energy levels in the particular atom and is given by

$$hf_{KL} = \frac{hc}{\lambda_{KL}} = E_K - E_L \quad (9.04)$$

For a transition between K and L-shells.

Thus the energy of the emitted photon depends on the binding energies in the K and L shells and hence the x-ray spectral lines have definite frequencies and wavelengths which are characteristic of the target atom.

For a given target material more than one spectral lines are observed as transitions may occur between different energy levels.

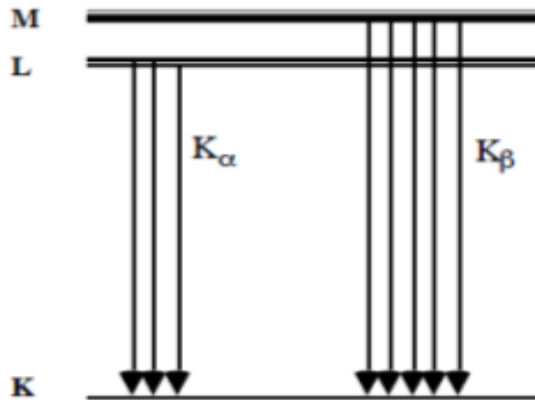

Fig.9.5: X-ray emission line due to transition of electron between levels.

The X-ray lines originating from the transition between the different electron levels are usually labelled by the symbols  $\alpha$ ,  $\beta$ ,  $\gamma$ , etc.

From L-level to K-level transition produces  $K_{\alpha}$ -line

From M-level to K-level transition produces  $K_{\beta}$ -line

From M-level to L-level transition produces  $L_{\alpha}$ -line

From N-level to L-level transition produces  $L_{\beta}$ -line

### 9.2.4 Checking my progress

1. What is the characteristic of X-ray characteristic peak radiation?
2. How is X-ray continuum produced via bremsstrahlung?
3. X-rays are generated when a highly accelerated charged particle such as electrons collide with target material of an X-ray tube. The resulting X-rays have two characteristics: the continuous X-rays (also called white X-rays) and characteristic X-rays peaks. The wavelength distribution and intensity of continuous X-rays are usually depending upon the applied voltage and a clear limit is recognized on the short wavelength side.
  - a. Estimate the speed of electron before collision when applied voltage is 30kV and compare it with the speed of light in vacuum.
  - b. In addition, establish the expression of the shortest wavelength limit  $\lambda_{\min}$  of X-rays generated with the applied voltage  $V$ . It is obtained when the incident electron loses all its energy in a single collision.

## 9.3 APPLICATIONS AND DANGERS OF X-RAYS

### ACTIVITY 9.4: investigating the X-ray uses and dangers

1. Using the historical background of X-ray discovery, what are the uses of X-rays in real life?
2. Discuss the dangers that X-rays may cause when they are used in a wrong way.

X-rays have many practical applications in medicine and industry. Because X-ray photons are of such high energy, they can penetrate several centimetres of solid matter. Hence they can be used to visualize the interiors of materials that are opaque to ordinary light, such as broken bones or defects in structural steel.

#### 9.3.1 In medicine

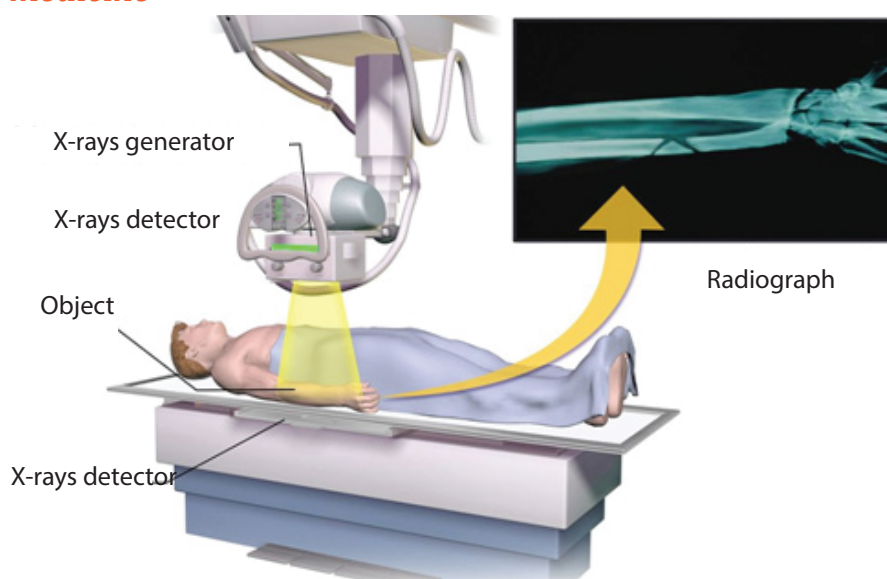

Fig.9.7: The radiology of human body using x-rays

X-ray imaging utilizes the ability of high frequency electromagnetic waves to pass through soft parts of the human body largely unimpeded. For medical applications, parts of the human body are exposed to moderated X-rays intensity and images are produced in similar way as light on a photographic plate or digital recorder to produce a radiograph (See Fig.9.7).

By rotating both source and detector around the patient's body a "slice" image can be produced in what is called computerized tomography (CT). Although CT scans expose the patient to higher doses of ionizing radiation the slice images produced make it possible to see the structures of the body in three dimensions.

In 1895, the Dutch Wilhelm Roentgen (See Fig.9.8) discovered that light energy could be used to take photographs through substances such as paper, cloths and wood. Roentgen also discovered that this invisible form of light energy, called X-rays could be used to take the pictures of structures inside the body as shown in Fig. below. Bone tissue appears clearly on an X-ray.

The object to be visualized is placed between an X-ray source and an electronic detector (like that used in a digital camera) or a piece of photographic film (Fig.9.8 or Fig.9.8B). The darker area in the recorded images by such a detector, the greater the radiation exposure. Bones are much more effective X-ray absorbers than soft tissue, so bones appear as light areas. A crack or air bubble allows greater transmission and shows as a dark area.

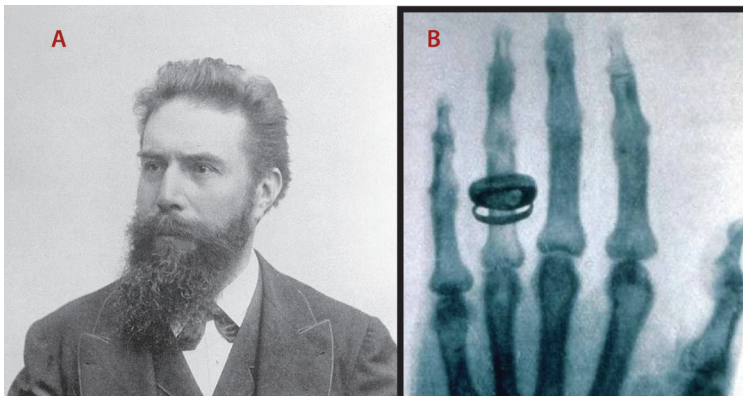

Fig.9.8: An X-ray picture (B) (radiograph) taken by Rontgen (A) of Albert von Kölliker's hand.

A widely used and vastly improved x-ray technique is *computed tomography*; the corresponding instrument is called a *CT scanner*. The x-ray source produces a thin, fan-shaped beam that is detected on the opposite side of the subject by an array of several hundred detectors in a line. Each detector measures absorption along a thin line through the subject. The entire apparatus is rotated around the subject in the plane of the beam, and the changing photon-counting rates of the detectors are recorded digitally. A computer processes this information and reconstructs a picture of absorption over an entire cross section of the subject.

In the middle 1970, CT (Computer Tomography) scanning machines were introduced in human medicine.

#### **X-rays are also used in the following:**

- Killing of cancerous cells
- Radiography is also used in industry for examining potentially damaged machinery to ascertain the cause of damage and to verify castings or welded joints

- X-rays are used to study the structure of crystals (crystallography).
- When a handgun is fired, a cloud of gunshot residue (GSR) is ejected from the barrel. The x-ray emission spectrum of GSR includes characteristic peaks from lead (*Pb*), antimony (*Sb*), and barium (*Ba*). If a sample taken from a suspect's skin or clothing has an x-ray emission spectrum with these characteristics, it indicates that the suspect recently fired a gun.

### 9.3.2 Examining luggage cargo and security.

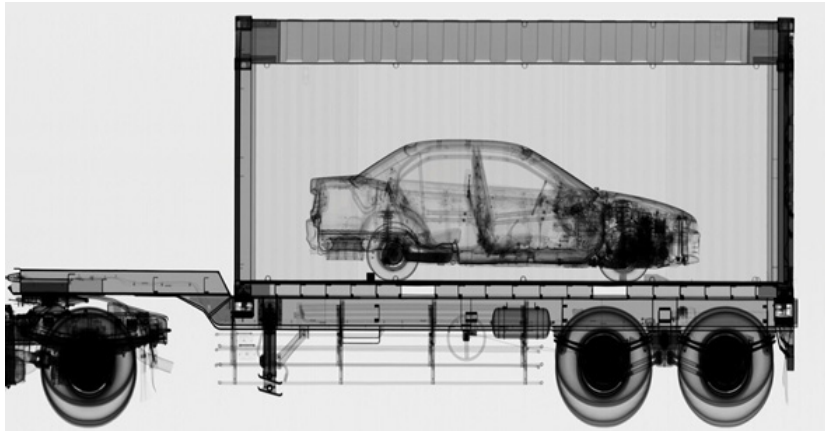

Fig.9. 9: Trailer carrying a car on check by X-rays

X-rays are being used in airports to examine luggage for weapons or bombs. Note that the metal detector that you walk through in the airport does not X-ray you. It uses magnetic waves to detect metal objects. X-rays are also being used to examine cargo luggage for illegal or dangerous material as in Fig.9.9.

### 9.3.3 In industry

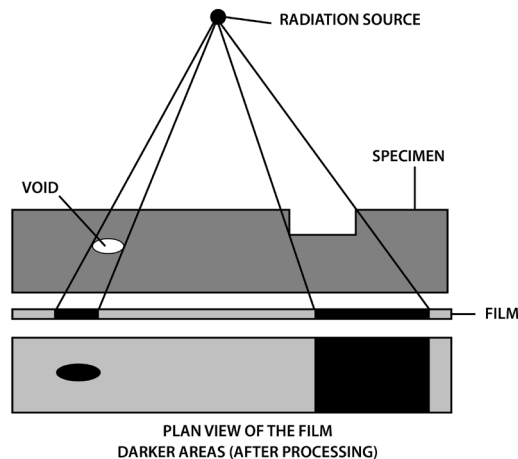

Fig.9.10: The view of cracks in metals checked by using X-rays

They can be used to detect structural problems and cracks in metals that cannot be seen from the outside. X-rays are used on commercial airplanes, bridges metals and pipe lines, to make sure there are no stress fractures or other dangerous cracks in the material.

### 9.3.4 In scientific research

- X-ray diffraction provides one of the most important tools for examining the three-dimensional (3D) structure of biological macromolecules and cells.
- They are also used in crystallography, where X-ray diffraction and scattered waves show the arrangement of atoms in the crystal.

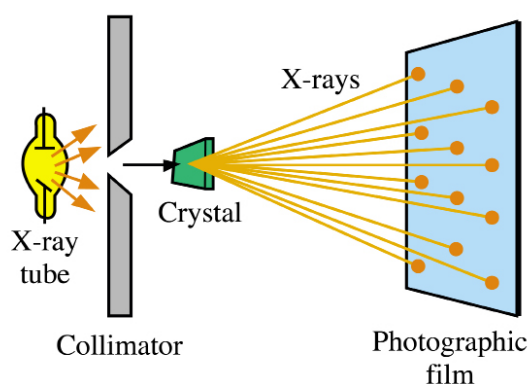

Fig.911: Schematic diagram of the technique used to observe the crystal structure by x-rays diffraction.

The array of spots formed on the film is called a Laue pattern and show the atom structure of the crystal.

### 9.3.5 Dangers of X-rays

- **X rays cause damage to living tissues.** As X-ray photons are absorbed in tissues, their energy breaks molecular bonds and creates highly reactive free radicals (such as neutral  $H$  and  $OH$ ), which in turn can disturb the molecular structure of proteins and especially genetic material. Young and rapidly growing cells are particularly susceptible, which is why X-rays are useful for selective destruction of cancer cells.
- Because X-rays can kill living cells, they must be used with extreme care. When improperly used they can cause severe burns, cancer, leukemia, and cataracts. They can speed aging, reduce immunity to disease, and bring about disastrous changes in the reproductive cells.
- Lead screens, sheets of lead-impregnated rubber, and leaded glass are used to shield patients and technicians from undesired radiation.
- The effect of X-ray radiations is cumulative. That is, many minor doses

over a number of years is equivalent to a large dose at one time.

- Unnecessary exposure to x-rays should be avoided. MRI (Magnetic Resonance Imaging) uses magnets and sound energy to form pictures of the internal organs without exposing patients to harmful X-rays.
- When they are used in hospitals, the sources should be enclosed in lead shields.
- A careful assessment of the balance between risks and benefits of radiation exposure is essential in each individual case.

### **9.3.6 Safety precaution measures of dangers caused by X-rays**

Medical and dental X-rays are of very low intensity, so that the hazard is minimized. However, X-ray technicians who go frequently behind the lead shield while operating X-rays need to be protected because of the frequency of exposure. A person can receive many medical or dental X-rays in a year with very little risk of getting cancer from it. In fact, exposure to natural radiation such as cosmic rays from space poses a greater risk.

**The following are some of the precautions:**

- i. Protective suits and wears such as gloves and eye glasses made of *lead* are used always when handling these radiations. These shields protect the workers from X-ray exposure.
- ii. Workers who operate equipment's that use X-rays must wear special badges which detect the amount of radiation they are exposed to.
- iii. Food and drinks are not allowed in places where X-radiations are present.
- iv. Experiments that involve these radiations (X-rays) substances should be conducted in a room surrounded by thick concrete walls or lead shields.
- v. Equipment that use X-rays should be handled using remote-controlled mechanical arms from a safe distance.

### **9.3.7 Checking my progress**

1. How do we create different X-ray images in medicine?
2. What are the dangers that may be caused by using excessive dose of X-rays?

## 9.4 PROBLEMS INVOLVING ACCELERATING POTENTIAL AND MINIMUM WAVELENGTH.

### 9.4.1 Accelerating potential and minimum wavelength

#### ACTIVITY 9.5: Calculation of accelerating potential in X-ray tube

An x-rays tube operates at 30 kV and the current through it is 2.0 mA. Calculate:

- The electrical power output
- The number of electrons striking the target per second.
- The speed of the electrons when they hit the target
- The lower wavelength limit of the X-rays emitted.

When a high voltage with several tens of kV is applied between two electrodes, the high-speed electrons with sufficient kinetic energy is drawn out from the cathode and collides with the anode. The electrons rapidly slow down and lose kinetic energy. Since the slowing down patterns(method of losing kinetic energy)varies with electrons, continuous X-rays with various wavelength are generated. When an electron loses all its energy in a single collision, the generated X-ray has the maximum energy (or the shortest wavelength  $\lambda_{swL}$  ). The value of the shortest wave length limit can be estimated from the accelerating voltage V between electrodes.

$$eV = hf_{\max} \quad (9.07)$$

$$\lambda_{swL} = \frac{c}{f} = \frac{hc}{ev} \quad (9.08)$$

Because X-rays are emitted by accelerated charges, x-rays are electromagnetic waves. Like light, X-rays are governed by quantum relationships in their interaction with matter. Thus, we can talk about X-ray **photons** or **quanta**, and the energy of an X-ray photon is related to its frequency and wavelength in the same way as for photons of light,

$$E = hf = \frac{hc}{\lambda} \quad (9.09)$$

Typical X-ray wavelengths are  $10^{-12}m$  to  $10^{-9}m$  . X-ray wavelength can be measured quite precisely by crystal diffraction techniques. X-ray emission is the inverse of the photoelectric effect. In photoelectric emission there is a transformation of the energy of a photon into the kinetic energy of an electron, in X-ray production there is a transformation of the kinetic energy of an electron into energy of a photon. In X-ray production we usually neglect the work function of the target and the initial kinetic energy of the boiled off electrons because they are very small in comparison to the other energies.

## EXAMPLE 9.1

Electrons in an X-ray tube accelerate through a potential difference of 10.0 kV before striking a target. If an electron produces one photon on impact with the target, what is the minimum wavelength of the resulting X-rays? (Answer using both SI units and electron volts.)

### Answer

To produce an x-ray photon with minimum wavelength and hence maximum energy, all of the electron's kinetic energy must go into producing a single x-ray

photon. We'll use Eq. (9.09) to determine the wavelength

$$\lambda_{\min} = \frac{hc}{eV} = \frac{(6.63 \times 10^{-34})(3 \times 10^8)}{(1.6 \times 10^{-19})(10.0 \times 10^3)} = 1.24 \times 10^{-10} = 0.124 \text{ nm}$$

Using electron volts, we have

$$\lambda_{\min} = hf_{\max} = \frac{hc}{eV_{AC}} = \frac{(4.136 \times 10^{-15} \text{ eV} \cdot \text{s})(3 \times 10^8 \text{ m/s})}{e(10.0 \times 10^3 \text{ V})} = 0.124 \text{ nm}$$

## Bragg's Law

According to W. L. Bragg (Weseda, Mastubara, & Shinoda, 2011), X-ray diffraction can be viewed as a process that is similar to reflection from planes of atoms in the crystal. In Bragg's construct, the planes in the crystal are exposed to a radiation source at a glancing angle  $\theta$  and X rays are scattered with an angle of reflection also equal to  $\theta$ . The incident and diffracted rays are in the same plane as the normal to the crystal planes (Fig.9. 4).

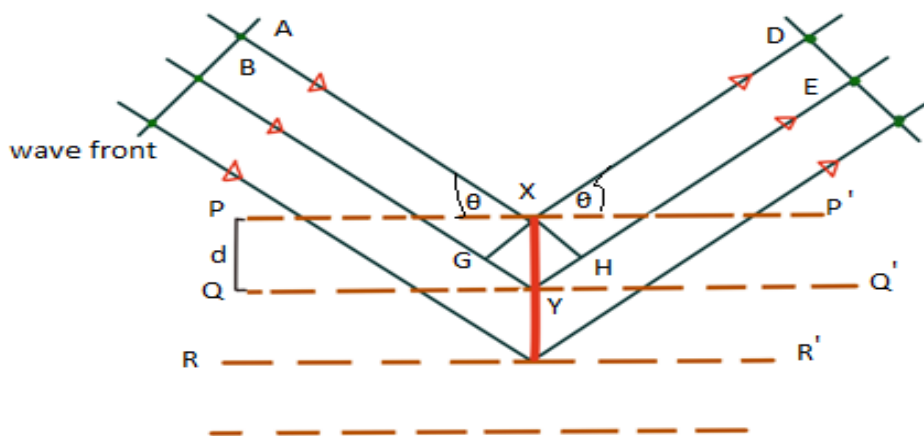

Fig.9. 4 Bragg's construction of x rays diffraction by a crystal

*Constructive interference* occurs only when the path difference between rays scattered from parallel crystal planes would be an integer number of wavelengths of the radiation. When the crystal planes are separated by a distance  $d$ , the path length difference would be  $2d \sin \theta$ . Thus, for constructive interference to occur the following relation must hold true.

$$n\lambda = 2d \sin \theta \quad (9.10)$$

This relation is known as Bragg's Law.

Thus for a given  $d$  spacing and wavelength, the first order peak ( $n = 1$ ) will occur at a particular  $\theta$  value. Similarly, the  $\theta$  values for the second ( $n = 2$ ) and higher order ( $n > 2$ ) peaks can be predicted.

From  $\frac{1}{2}mv^2 = eV$  and  $p = mv$  so  $p = \frac{h}{\lambda}$

$v = \sqrt{\frac{2eV}{m}}$  and  $p = mv$  so  $\lambda = \frac{h}{mv}$

Then  $2d \sin \theta = \frac{nh}{\sqrt{\frac{2eV}{m}}} = \frac{nh}{\sqrt{2eVm}}$

Where  $\lambda = \frac{h}{\sqrt{2eVm_e}}$  is de Broglie wavelength

De Broglie relation can also be written as  $\lambda = \frac{12.27}{\sqrt{V}} A^\circ$  where  $A^\circ = 10^{-10} m$

The above derivation assumes that phase differences between wavelengths scattered at different points depend only on path differences. It is assumed that there is no intrinsic phase change between the incident and scattered beams or that this phase change is constant for all scattering events.

### EXAMPLE 9.2

Monochromatic X-rays of wavelength  $1.2 \times 10^{-10} m$  are incident on a crystal. The 1<sup>st</sup> order diffraction maximum is observed at when the angle between the incident beam and the atomic plane is  $12^\circ$ .

What is the separation of the atomic planes responsible for the diffraction?

**Answer:**

According to Bragg's law  $n\lambda = 2d \sin \theta$  and  $n = 1$

Therefore  $\lambda = 2d \sin \theta \Leftrightarrow d = \frac{\lambda}{2 \sin \theta} = \frac{(1.2 \times 10^{-10})}{2 \sin 12} = 2.89 \times 10^{-10} m$

### 9.4.2 Checking my progress

1. Calculate
  - a. Strength of the electric field  $E$ ,
  - b. Force on the electron  $F$ ,
  - c. Acceleration  $a$  of electron, when a voltage of 10 kV is applied between two electrodes separated by an interval of 10 mm.
  
2. Crystal diffraction experiment can be performed using X-rays, or electrons accelerated through appropriate voltage. Which probe has greater energy? (For quantitative comparison, take the wavelength of the probe equal to  $1\text{\AA}$ , which is of the order of inter-atomic spacing in the lattice) ( $m_e = 9.11 \times 10^{-31}\text{kg}$ ).

## END UNIT ASSESSMENT 9

### A Multiple choices

1. Choose the letter that best matches the true answer:

I. X-rays have

- a. Short wavelength
- b. high frequency
- c. Both A and B
- d. Longest wavelength

II. If fast moving electrons rapidly decelerate, then rays produced are

- a. Alpha rays
- b. x-rays
- c. beta rays
- d. gamma rays

III. Energy passing through unit area is

- a. Intensity of x-ray
- b. Frequency of x-ray
- c. wavelength of x-ray
- d. Amplitude of x-ray

IV. X-rays are filtered out of human body by using

- a. Cadmium absorbers
- b. Carbon absorbers
- c. Copper absorbers
- d. Aluminum absorbers

V. Wavelength of x-rays is in range

- a.  $10^{-8}$  m to  $10^{-13}$  m
- b.  $10^{-7}$  m to  $10^{-14}$  m
- c.  $10^{-10}$  m to  $10^{-15}$  m
- d.  $10^2$  m to  $10^9$  m

### B. Structured questions

2. A plot of x-ray intensity as a function of wavelength for a particular accelerating voltage and a particular target is shown in Fig.10.5.

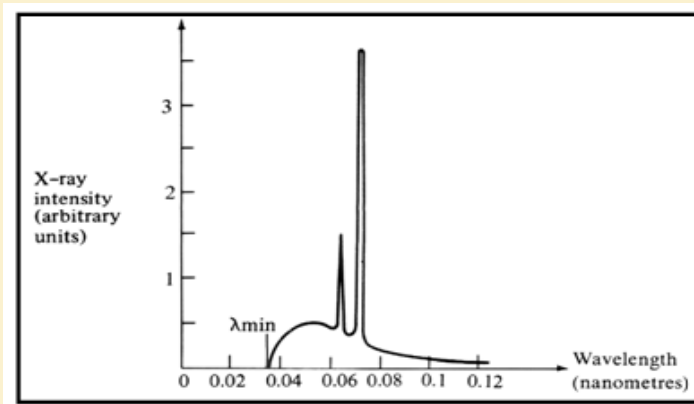

Fig.9. 5Characteristics of x rays spectrum

- a. There are two main components of this x-ray spectrum: a broad range of x-ray energies and a couple of sharp peaks. Explain how each of these arises.
  - b. What is the origin of the cut-off wavelength  $\lambda_{\min}$  of the Fig.9.5 shown below? Why is it an important clue to the photon nature of x-rays?
  - c. What would happen to the cut-off wavelength if the accelerating voltage was increased? What would happen to the characteristic peaks? Use a sketch to show how this spectrum would look if the accelerating voltage was increased.
  - d. What would happen to the cut-off wavelength if the target was changed, keep the same accelerating voltage? What would happen to the characteristic peaks? Use a sketch to show how the spectrum would look if some other target material was used, but the accelerating voltage was kept the same.
3. Electrons are accelerated from rest through a p.d of 10 kV in an x ray tube. Calculate:
    - I. The resultant energy of the electrons in eV.
    - II. The wavelength of the associated electron waves. ( $1.23 \times 10^{-11} \text{m}$ )
    - III. The maximum energy and the minimum wavelength of the x ray radiation generated (assume  $h = 6.62 \times 10^{-34} \text{ J.S}$ ,  $c = 3 \times 10^8 \text{ m/s}$ ,  $(1.6 \times 10^{-15} \text{ J}, 1.24 \times 10^{-10} \text{ m})$ ).
  4. Monochromatic X-ray of wavelength  $1.2 \times 10^{-10} \text{ m}$  are incident on a crystal. The 1<sup>st</sup> order diffraction maximum is observed at when the angle between the incident beam and the atomic plane is  $12^\circ$ . What is the separation of the atomic planes responsible for the diffraction?
  5. An x-ray operates at 30 kV and the current through it is 2.0 mA. Calculate:
    - I. The electrical power output
    - II. The number of electrons striking the target per second.
    - III. The speed of the electrons when they hit the target
    - IV. The lower wavelength limit of the x-rays emitted.
  6. An x-ray machine can accelerate electrons of energies  $4.8 \times 10^{-15} \text{ J}$ . The shortest wavelength of the x-rays produced by the machine is found to be  $4.1 \times 10^{-11} \text{ m}$  Use this information to estimate the value of the plank constant.

7. The spacing between Principal planes of *Nacl* crystal is  $2.82 \text{ \AA}$  . It is found that the first order Bragg diffraction occurs at an angle of  $10^\circ$ . What is the wavelength of the x rays?

8. What is the kinetic energy of an electron with a de Broglie wavelength of 0.1 nm. Through what p.d should it be accelerated to achieve this value?

9. You have decided to build your own x-ray machine out of an old television set. The electrons in the TV set are accelerated through a potential difference of 20 kV. What will be the  $\lambda_{\min}$  for this accelerating potential?

10. A tungsten target ( $Z = 74$ ) is bombarded by electrons in an x-ray tube. The K, L, and M atomic x-ray energy levels for tungsten are -69.5, -11.3 and -2.30 keV, respectively.

- Why are the energy levels given as negative values?
- What is the minimum kinetic energy of the bombarding electrons that will permit the production of the characteristic  $K\alpha$  and  $K\beta$  lines of tungsten?
- What is the minimum value of the accelerating potential that will give electrons this minimum kinetic energy?
- What are the  $K\alpha$  and  $K\beta$  wavelengths?

11. Using the following illustration figure Fig.10.6, label each part marked by letter from A to H and explain the function of each part A, B, C, D, E, F and H.

e.

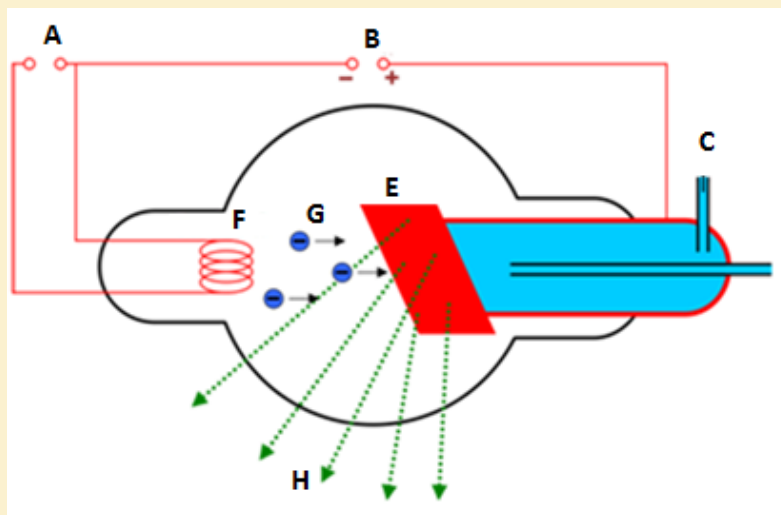

Fig.9. 6 X ray tube illustration

# UNIT 10

## EFFECT OF LASER



**Key unit Competence:** Analyze the applications of LASER.

My goals

- Define a laser beam
- Explain the stimulated emission of light
- Explain the spontaneous emission of light
- Analyse the mechanism to produce LASER beam
- Explain laser properties
- Explain and describe monochromatic and coherent sources of light
- Analyse a LASER light as a source of coherent light.
- Explain the principle and uses of Laser.
- Outline applications of LASER
- Analyse applications and dangers of LASER beam
- Analyse precautional measures of the negative effects of Laser.

## INTRODUCTORY ACTIVITY

A man has tied all forms of advancements from traditional methods of solving problems to advanced methods by use of different technologies. Among other technological advancements, discovery of Laser that is a part of visible light under electromagnetic waves has had a great impact in solving many of our problems.

- What do you understand by Electromagnetic waves?
- Discuss at least four (4) characteristics of Electromagnetic waves
- In your own words, discuss how these electromagnetic waves are produced.
- Are all kinds of these electromagnetic waves have the same energy? If Yes why? If No, why not?
- Basing on what you know about these electromagnetic waves, what could be positive uses of these waves. Also discuss negative effects of electromagnetic waves.
- How are electromagnetic waves related to LASERS?

## 10.1 CONCEPT OF LASER

### ACTIVITY 10.1

- From your own understanding, explain how a LASER light is produced.
- Does production, need source of energy like electricity. Explain your reasoning.
- In energy levels, particles are either in ground or excited states. Is laser formed when particles or electrons are in ground or excited states? Explain your reasoning.

The acronym **LASER** stands for **Light Amplifier by Stimulated Emission of Radiation**. This expression means that the light is formed by stimulating a material's electrons to give out the laser light or radiation.

The laser is a device that uses the ability of some substances to absorb electromagnetic energy and re-radiate it, as a highly focused beam of monochromatic and synchronized wavelength radiation. In 1953 Charles H. Townes, with graduate students James P. and Herbert J., produced the first **Microwave Amplifier by Stimulated Emission of Radiation** (MASER),

as a device operating in the same way as a laser, but amplifying microwave radiations.

This system could release stimulated emissions without falling to the ground state, and thus maintaining a population inversion. A laser is a device that emits light through a process of optical amplification based on the stimulated emission of electromagnetic radiation. That is, the **laser** is a light source that produces a beam of highly coherent and very nearly monochromatic light because of cooperative emission from many atoms.

### 10.1.1 Absorption, Spontaneous emission and Stimulated emission

#### ACTIVITY 10.2

- Using scientific explanations, Explain the meaning of the following terms
  - Absorption
  - Stimulated emission
  - Spontaneous emission
- Electrons can jump from excited to ground state; does it absorb or radiate energy. Explain your reasoning.
- Write an equation that would be used to calculate the energy radiated by an electron when it jumps from one energy level to another. Explain each term used in the equation.
- What do you understand by the term population inversion?

#### a. Absorption

During the process of absorption, a photon from the source is destroyed and the atom which was at the ground state is promoted to the excited state.

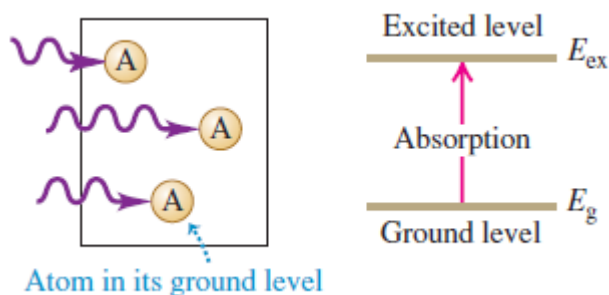

Fig.10. 1Absorption process

If  $n_0$  is the number of atoms per unit volume in the ground state with energy  $E_g$ , then the number of atoms per unit volume in the excited state of energy  $E_{ex}$  at temperature  $T$ , will depend on both the thermal energy and the difference between the energy levels and is given by  $n = n_0 e^{-\frac{E}{kT}}$

where  $K = 1.38 \times 10^{-23} J/K$  and  $E$  is the difference between energy levels,  $E = E_{ex} - E_g$

Let  $n_1$  and  $n_2$  be the number of atoms per unit volume in the states of energies  $E_1$  and  $E_2$  respectively. The ratio between the population of the two levels is ,

$$\frac{n_2}{n_1} = e^{-\frac{E_2 - E_1}{kT}}$$

If  $E_2 > E_1$ ,  $n_2 < n_1$  then (as the right side of the equation is less than a unit i.e.  $E_2 - E_1 \gg kT$ )

In normal cases the excited states are less populated than the ground state.

### b. Spontaneous emission.

An atom or an electron can move from one energy level to another. A photon is released when an electron moves from a higher energy level to a lower energy level. The release of photon (a particle of light) is called spontaneous emission.

At the excited state, an atom will drop to a lower level by emitting a photon of radiation in a process called spontaneous emission. It emits the photon spontaneously after an average time  $\tau$  called the **spontaneous lifetime** of the level. This time depends on the atomic species; some levels have long lifetime measured in seconds, whereas others are relatively short on the order of nanoseconds or less. This lifetime determines the ability of the emitting atom to store energy and will affect the efficiency of sources.

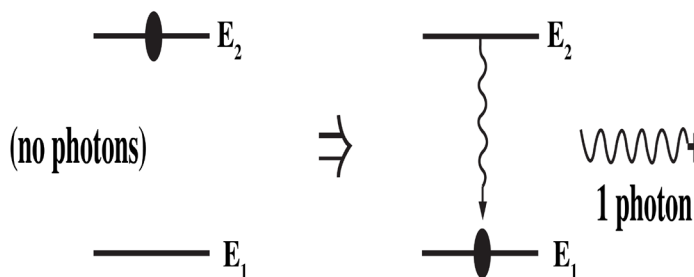

Fig.10. 2 Process of spontaneous emission

When an excited atom, depending on its lifetime at the higher energy level, comes down to lower energy level, a photon is emitted, corresponding to the equation,

$$hf = E_2 - E_1$$

where  $h$  is the Planks constant,  $f$  is the frequency of the emitted photon

$E_2$  and  $E_1$  correspond to higher and lower energy levels respectively.

This process of spontaneous emission is a random process and the probability of such transition depends on the number of atoms in the excited state  $n_2$ . The number of such transition per unit volume per second is  $A_{21}n_2$  where  $A_{21}$  is known as the Einstein's constant.

### C. Stimulated emission

Stimulated emission occurs when a photon strikes an atom that is excited state and makes the atom emit another photon

In **stimulated emission** (Fig. 10.3), each incident photon encounters a previously excited atom. A kind of resonance effect induces each atom to emit a second photon with the same frequency, direction, phase, and polarization as the incident photon, which is not changed by the process. For each atom there is one photon before a stimulated emission and two photons after—thus the name *lightamplification*. Because the two photons have the same phase, they emerge together as *coherent* radiation.

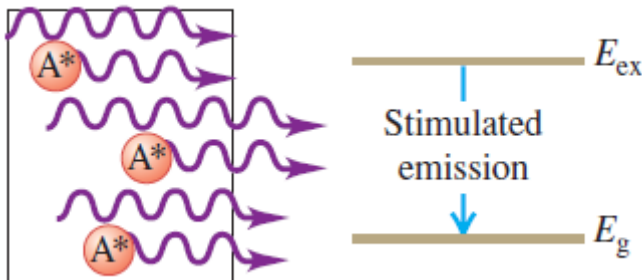

Fig.10. 3: Stimulated emission process

Let us now suppose that the atom is found initially in level 2 and that an electromagnetic wave of frequency  $f = f_o$  (i.e. equal to that of the spontaneously emitted wave) is incident on the material. Since this wave has the same

frequency as the atomic frequency, there is a finite probability that this wave will force the atom to undergo the transition  $E_2 \rightarrow E_1$ .

In this case the energy difference between the two levels is emitted in the form of electromagnetic wave that adds to the incident one. This is the phenomenon of stimulated emission. There is a fundamental difference between the spontaneous and stimulated emission processes because in spontaneous emission one photon is emitted and in stimulated emission both incident and emitted photons are observed.

### 10.1.2 Laser principle

The principle of operation remains the same though there is a wide range of lasers. Laser action occurs in three stages: photon absorption, spontaneous emission, and stimulated emission. The particle of the material, which undergoes the process of excitation, might be an atom, molecule, or ion depending on the laser material. This principle is based on the principle of stimulated emission of radiation, the theory that was discussed by Einstein in 1917. The whole concept was discussed in the previous section.

The photon emitted during stimulated emission has the same energy as the incident photon and it is emitted in the same direction as the latter, thus, getting two coherent photons. If these two coherent photons are incident on other two atoms in  $E_2$ , then it will result in emission of two more photons and hence four coherent photons of the same energy are emitted. The process continues leading to doubling of the present number of photons.

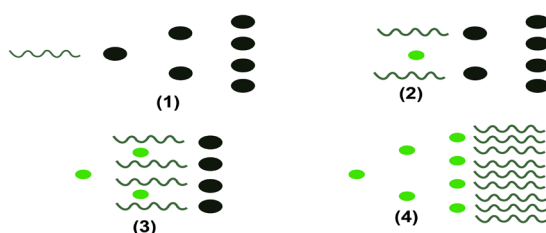

Fig.10. 4 Amplification due to stimulated emission of radiation

If the process is made to go on chain, we ultimately can increase the intensity of coherent radiation enormously. In figure above, such amplification of the number of the coherent photons due to stimulated emission is shown.

The necessary condition for this type of amplification of light intensity by stimulated emission of radiation is that number of atoms in the upper energy state  $E_2$  must be sufficiently increased.

### 10.1.3 Population inversion

**Population inversion:** This is the process of increasing excited electrons in higher energy levels. This is the redistribution of atomic energy levels that takes place in a system so that **laser** action can occur.

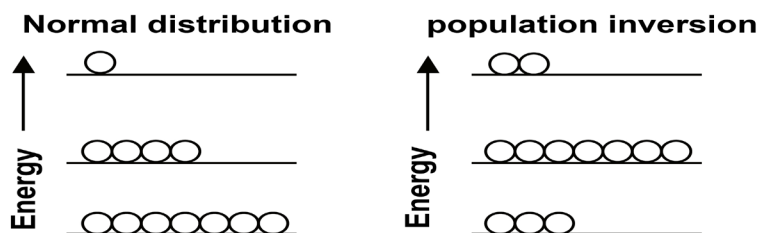

Fig.10. 5 increase of electrons in excited energy levels

There are different methods of achieving population inversion in atomic states that is essential requirement to produce laser beam.

Normally, most of the atoms in a medium are in the ground state of energy  $E_0$ . There are four different methods of making these atoms to excited states.

- i. Excitation with the help of photons. If the atoms are exposed to an electromagnetic radiation of high frequency, then there is selective absorption of energy and thus atoms are raised to excited state.
- ii. Excitation by electrons. This method is used in some gas lasers. Electrons are released from the atoms due to high voltage electric discharge through a gas. These electrons are then accelerated to high velocities due to high electric field inside a discharge tube. When they collide with neutral gas atoms, a fraction of these atoms are raised to excited state  
$$e + X \rightarrow X^* + e$$
 Where  $X$  is an atom in ground state and  $X^*$  is an atom in excited state
- iii. Inelastic collision between atoms. If a gas contains two different two different kinds of atoms  $X$  and  $Y$ , then during electric discharge through the gas some of the atoms are raised to excited state.
- iv. Excitation by chemical energy. Sometimes, an atom or a molecule can be a product of a chemical reaction and can be produced in its excited state. An example is hydrogen combining with fluorine to form hydrogen fluoride  $\text{HF}$  that is in excited state.

## 10.1.4 Laser structure

### ACTIVITY 10.3

1. From what you know about LASER, what could be the components of laser
2. Are all parts on laser Light Similar? Explain your reasoning.

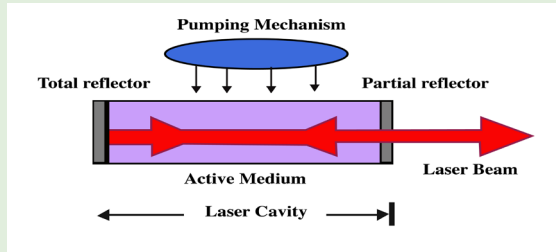

Fig.10. 6: General structure of Laser

In general case laser system consists of three important parts: **Active medium** or **amplifying medium**, the energy source referred to as the **pump** or pump source and the **optical resonator** consisting of mirrors or system of mirrors.

#### Pumping Mechanism.

Pumping is the process of supplying energy to the laser medium to excite to the upper energy levels. To have this mechanism, it depends on the existence of interactions between light from pump source to constituents of active medium. Usually, pump sources can be: electrical discharges, flash lamps, arc lamps, light from another laser, chemical reactions and even explosive devices. Most common lasers use electrical or optical pumping. The type of pump source used depends essentially on the gain medium.

#### Active Medium

The active medium is the major determining factor of the wavelength of operation, and other properties of the laser. The gain medium is excited by the pump source to produce a population inversion, and it is where the spontaneous and stimulated emission of photons take place, leading to the phenomenon of optical gain or amplification. The gain medium may be a solid crystal like a ruby, a liquid dye, gases like  $\text{CO}_2$  or He-Ne or semiconductors. The gain medium for some lasers like gas lasers is closed by a window under the Brewster's angle to allow the beam to leave the laser tube.

#### Optical resonator or Optical cavity

The optical resonator or optical cavity is a system of two parallel mirrors placed around the gain medium that provide reflection of the light beam. Light from the medium produced by the spontaneous emission is reflected by the mirrors

back into the medium where it may be amplified by the stimulated emission. Mirrors are required for most lasers to increase the circulating power within the cavity to the point where gains exceed losses, and to increase the rate of stimulated emission. One of the mirrors reflects essentially 100% of the light, while the other less than 100% and transmits the remainder. Mirrors can be plane, spherical or a combination of both. Here represented are the common cavities configuration that can be used:

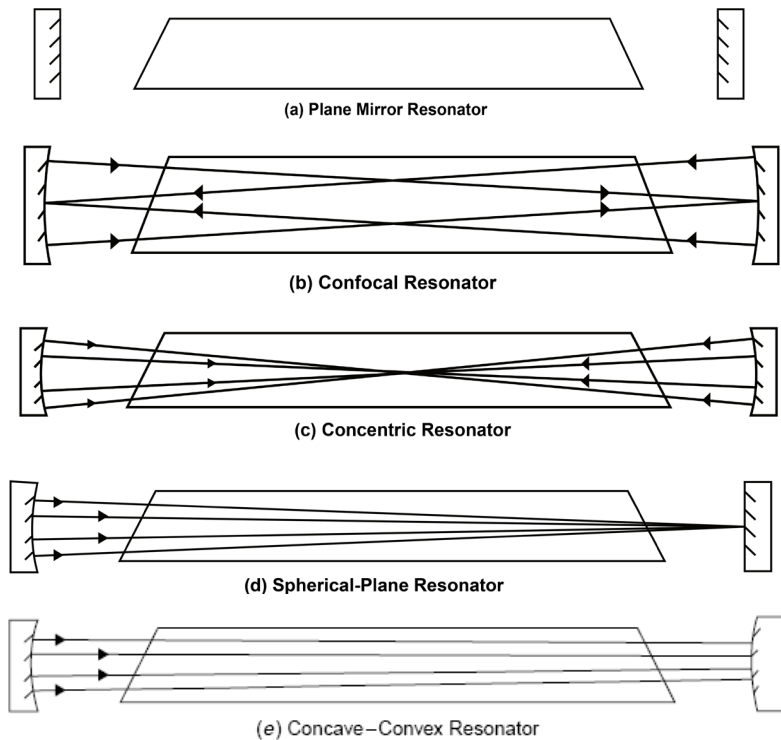

### 10.1.5 Checking my progress

1. What do you understand by the term LASER?
2. Write in full the acronym L.A.S.E.R
3. In your own words, explain how laser light is produced.
4. Explain the meaning of population inversion and discuss how an atom can be put into excited state.
5. What is the energy of the laser light that propagates with a frequency of  $10^{10}$  Hz in gaseous medium. (Given that the plank's constant  $h = 6.67 \times 10^{-34} J.s$ )
6. What are the three major components of laser?
7. Using diagrams, explain all the types of optical cavity.

## 10.2 PROPERTIES OF LASER LIGHT

### ACTIVITY 10.4

- Using the ideas about electromagnetic radiations, what are characteristics of laser light?
- Do you think all different kinds of laser light have the same properties? Give reasons to support your answer.

The laser light is not like any other light emitted by usual sources found in nature. This special light emitted by the laser, has three properties according to its usefulness in many applications: Coherence, Monochromaticity and Collimation or Directionality.

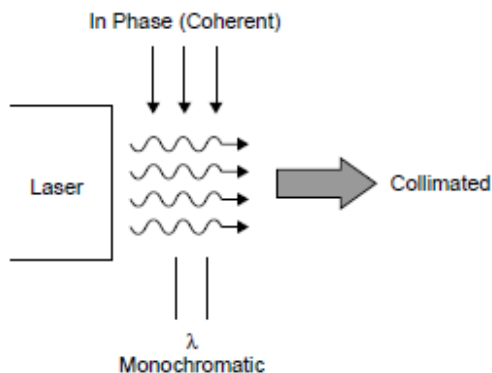

Fig 10.8 Properties of laser light

### 10.2.1 Coherence

Coherence is the most interesting property of laser light. All photons emitted, are exactly in the same phase, they are all **crest** and **valley** at the same time. It is brought about by the mechanism of the laser itself in which photons are essentially copied. The good temporal coherence is essentially for Interferometry like in Holography. Coherence is not trivial and is brought about by the amplification mechanism of the laser.

### 10.2.2 Monochromaticity

Monochromaticity is the ability of the laser to produce light that is at one wavelength  $\lambda$ . It is a requirement for coherence since photons of different wavelengths cannot be coherent. When white light is dispersed through a prism, you note that it is composed of an infinite number of wavelengths of light covering the entire visible spectrum as well as into the UV and IR regions. However, no light source is perfectly monochromatic. Lasers tend to be relatively

monochromatic and this depends on the type of laser. Monochromatic output, or high frequency stability, is of great importance for lasers being used in Interferometry.

### 10.2.3 Collimation or Directionality

Collimation or directionality is the property of laser light that allows it to stay in one direction at the straight line, confined beam for large distances. This property makes it possible to use the laser as a **level** in construction or to pinpoint speeders on a highway. This highly directional laser light is determined by the mechanism of the laser itself.

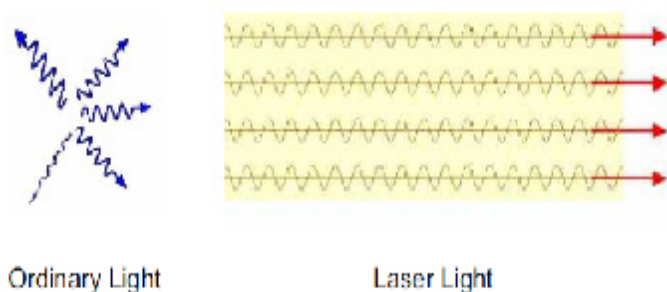

Fig.10. 9 Specific direction of laser light

### 10.2.4 Checking my progress

1. Choose the correct group of terms that are properties of laser light.
  - a. Coherent, unpolarized, monochromatic, high divergence
  - b. Monochromatic, low divergence, polarized, coherent
  - c. Polychromatic, diffuse, coherent, focused
  - d. Monochromatic, birefringent, nonpolarized, coherent
2. Which of the following properties of laser light enables us to use it to measure distances with great precision?
  - a. All the light waves emitted by the laser have the same direction
  - b. The light waves are coherent
  - c. The light waves are monochromatic
  - d. The individual waves effectively work like a single wave with very large amplitude.
3. Explain how coherence, monochromatic and collimation are interconnected.
4. All light in laser light are produced and found to be in the same phase. How does this help in the formation of 3D images?
5. Laser light can be used as a level. Which special feature that makes it be used

## 10.3 APPLICATIONS AND DANGERS OF MISUSE OF LASER

### 10.3.1 Applications of lasers.

#### ACTIVITY 10.5



- Having studied LASERS, where do you think in real life LASERS are helpful?
- From your experience, have you ever used LASER light?
- Other than using it by yourself, what are other places where laser light is applied

There are many interesting uses for lasers, depending on the special characteristic being applied. Laser Diodes are used in a wide range of applications. Partial lists of those applications include:

- They are used in common consumer devices such as DVD players, bar code scanners; CD ROM drivers; laser disc and other optical storage drivers; laser printers and laser fax machines; sighting and alignment scopes; measurement equipment; free space communication systems; pump source for other lasers; high performance imagers; and typesetters. CD players have lasers. Light from the laser in CD player reflects off patterns on CD's surface. The reflected light is converted to a sound wave.
- Laser beams can be used in diverse fields of science and technology. Like in the control of motion of moving objects like aircrafts or missiles. This method thus makes it possible for a missile to hit a certain target.
- Because of high directional property, lasers are used to measure distances accurately. A laser beam is sent and the time taken for it to be reflected back is measured. Using this idea, the distance can thus be measured.
- Because laser beam can be focused into a small spot, it can thus be used to cut minute holes onto a material.
- The very high intensity of laser beam means that the amplitude of the

corresponding electromagnetic wave is very large. So it is possible to investigate the non linear optical properties of different materials with the help of laser light.

- vi. Lasers are also used in industry for cutting materials such as metal and cloths. and welding materials
- vii. Doctors use lasers for surgery and various skin treatments
- viii. They are used in military and law enforcement devices for marking targets and measuring range and speed.
- ix. Laser lighting displays use laser light as an entertainment medium.
- x. Lasers also have many important applications in scientific research .

In a tabular way, we can have a summary of different types of lasers and their applications.

The following are types of lasers and their Applications

**a. Gas Lasers:**

Laser Gain Medium	Operation Wavelength(s)	Pump Source	Applications
Helium-neon laser	632.8nm	Electrical discharge	Holography, spectroscopy, barcode scanning, alignment, optical demonstrations
Argon laser	454.6 nm, 488.0 nm, 514.5 nm	Electrical discharge	Retinal phototherapy (for diabetes), lithography, confocal microscopy, spectroscopy pumping other lasers
Carbon dioxide laser	10.6 $\mu\text{m}$ , (9.4 $\mu\text{m}$ )	Electrical discharge	Material processing (cutting, welding, etc.), surgery
Excimer laser	193 nm (ArF), 248 nm (KrF), 308 nm (XeCl), 353 nm (XeF)	Excimer recombination via electrical discharge	Ultraviolet lithography for semiconductor manufacturing, laser surgery

*Table.10. 1 Gas lasers and their applications*

## b. Solid State Lasers:

Laser Gain Medium	Operation Wavelength(s)	Pump Source	Applications
Ruby laser	694.3nm	Flash Lamp	Holography, tattoo removal. The first type of visible light laser invented; May 1960.
Nd:YAG laser	1.064 $\mu\text{m}$ , (1.32 $\mu\text{m}$ )	Flash Lamp, Laser Diode	Material processing, laser target designation, surgery, research, pumping other lasers. One of the most common high power lasers.
Erbium doped glass lasers	1.53-1.56 $\mu\text{m}$	Laser diode	um doped fibers are commonly used as optical amplifiers for telecommunications.
F-center laser	Mid infrared to far infrared	Electrical current	Research purposes.

*Table.10. 2 Solid state lasers characteristics and their applications.*

## c. Metal-vapor Lasers:

Laser Gain Medium	Operation Wavelength(s)	Pump Source	Applications
Helium-cadmium (HeCd) metal-vapor laser	441.563 nm, 325 nm	Electrical discharge in metal vapor mixed with helium buffer gas.	Printing and typesetting applications, fluorescence excitation examination
Copper vapor laser	510.6 nm, 578.2 nm	Electrical discharge	Dermatological uses, high speed photography, pump for dye lasers

*Table.10. 3 Metal-vapor lasers characteristics and their applications*

#### d. Other types of lasers:

Laser Gain Medium	Operation Wavelength(s)	Pump Source	Applications
Dye lasers	Depending on materials, usually a broad spectrum	Other laser, flash lamp	Research, spectroscopy, birthmark removal, isotope separation.
Free electron laser	A broad wavelength range (about 100 nm - several mm)	Relativistic electron beam	Atmospheric research, material science, medical applications

Table.10. 4 Other kinds of lasers characteristics and their applications

### 10.3.2 Dangers of lasers

#### ACTIVITY 10.6

Laser light is used in many areas like industries, offices, airports and many other places. Do you think long exposure of laser light is harmful?

1. Why do you think so?
2. What makes these lasers harmful if mis-used? Give a scientific reasoning

You should be careful when dealing with lasers, because they can have a negative impact when exposed to your body. Among other negative effects, some of them are discussed below .

- i. If directly exposed to our skin, it burns the skin
- ii. When absorbed by skin, Laser light reacts with body cells causing cancer.
- iii. Because of their high energy, it affects eyes if exposed to them
- iv. Lasers can affect cells of a human being. This leads to mutation

Because of the negative effects of lasers, care must be taken to avoid all the risks of being affected by lasers.

### 10.3.3 Precaution measures

#### ACTIVITY 11.7



- a. Observe the picture above clearly. Using scientific reasoning explain why the people performing the activity above are putting on protective wear as shown.
- b. Building on what you have discussed in a) above, what precautional measures can you take to avoid negative effects of LASERS if at all you were working in a place exposed to them.

The following are some of the measures one can take to avoid the negative effects of lasers.

- i. For any one working in places where there are incidences of being exposed to laser light, one should wear protective clothes, glasses and shoes so that there is no direct exposure of these radiations on to the body.
- ii. One should minimize the time of working with lasers.
- iii. Areas that are exposed to these radiations should be warning signs and labels so that one can be aware of places/areas where laser light is used.
- iv. Safe measures like Use of remote control should be used to avoid direct exposure of these radiations (LASER light).
- v. People should be given trainings on how to handle lasers.
- vi. There should also access restrictions to laboratories that use laser

### ***10.3.4 Checking my progress***

1. Discuss all the negative effects of laser light.
2. Using vivid examples, explain how one can prevent him or herself of all dangers caused by laser light.
3. We have seen that laser light is good and at the same time bad. Using your personal judgement, which side outweighs the other. Give scientific reasons.
4. Depending on your judgement in (3) do you think man should continue using laser light?

## END UNIT ASSESSMENT 10

### A. Multiple choice

Copy the questions below to your exercise and chose the best alternative that answers the question.

1. What does the acronym LASER stand for?
  - a. Light Absorption by Stimulated Emission of Radiation
  - b. Light Amplification by Stimulated Emission of Radiation
  - c. Light Alteration by Stimulated Emission of Radiation
2. The acronym MASER stands for?
  - a. Microwave Amplification by Stimulated Emission of Radiation
  - b. Molecular Absorption by Stimulated Emission of Radiation
  - c. Molecular Alteration by Stimulated Emission of Radiation
  - d. Microwave amplification by Stimulated Emission of Radio waves
3. What is one way to describe a Photon?
  - a. Solid as a rock
  - b. A wave packet
  - c. A torpedo
  - d. Electromagnetic wave of zero energy
4. Which of the following determines the color of light?
  - a. Its intensity
  - b. Its wavelength
  - c. Its source
  - d. Some information missing
5. Among the three examples of laser listed below, which one is considered “eye safe”?
  - a. Laser bar-code scanners
  - b. The excimer laser
  - c. Communications lasers
  - d. YAG
6. Why are lasers used in fiber optic communications systems
  - a. The government has mandated it
  - b. They can be pulsed with high speed data
  - c. They are very inexpensive
  - d. They are not harmful

7. Lasers are used in CDs and DVDs. What type of laser is used in these players?
  - a. Semiconductor
  - b. YAG
  - c. Alexandrite
  - d. All the above
8. The best reason why lasers used in “Laser Printers” is
  - a. They can be focused down to very small spot sizes for high resolution
  - b. They are cheap
  - c. They are impossible to damage
  - d. They are locally available
9. As wavelength gets longer, the laser light can be focused to...
  - a. Larger spot sizes
  - b. Smaller spot sizes
  - c. Large and small spot sizes
  - d. None of the above
10. Among the following, which color of laser has the shortest wavelength?
  - a. Yellow
  - b. Red
  - c. Blue
  - d. Green
11. What property of laser light is used to measure strain in roadways?
  - a. Intensity
  - b. Power
  - c. Coherence
  - d. All the above
12. What is the type of laser used most widely in industrial materials processing applications?
  - a. Dye Laser
  - b. Ruby Laser
  - c. YAG laser
  - d. Carbon Dioxide Laser
13. Why are lasers used for cutting materials
  - a. It never gets dull
  - b. Accuracy
  - c. Repeatability
  - d. It has a small “heat affected zone”
  - e. Smoother cuts
  - f. All of the above

14. The Excimer laser produces light with what wavelength?
  - a. Visible
  - b. Ultraviolet
  - c. Infrared
  - d. All the above.
15. Most lasers are electrically inefficient devices.
  - a. True
  - b. False
16. Chemical lasers use..... to produce their beams.
  - a. Excessive amounts of electrical power
  - b. Small amounts of electrical power
  - c. No electrical power
  - d. Other lasers
17. What type of laser could cause skin cancer if not used properly?
 

a. Red semiconductor laser	c. Blue semiconductor
b. Excimer laser	d. YAG laser.

### B. Structured questions

18.
  - a. What do you understand by term LASER?
  - b. Depending on the nature and what laser is made of, Laser is classified into different types. Discuss at least 5 types of lasers.
- 19 The following are basic characteristics of laser light. With clear explanation, what does each imply as connected to laser light.
  - a. Coherence
  - b. Monochromaticity
  - c. Collimation
20. a. With the aid of diagram Explain the meaning of the following terms
  - I. Spontaneous Absorption of light
  - II. Stimulated Emission cause harm if mis-used In what ways is laser light harmful.
  - III. Spontaneous Emission
  - IV. Population inversion
  - b. Laser light have been employed in different areas. This has helped man in solving different problems. What are some of the areas where laser light is employed.
  - c. Though laser light is very important in different activities, it can also

# UNIT 11

## MEDICAL IMAGING



**Key unit Competence:** Analyze the processes in medical imaging.

**Learning objectives:**

- Outline specific purposes of imaging techniques
- Explain the effects of various imaging techniques for particular purposes.
- Explain the basic functioning principles of major medical imaging techniques
- Identify advantages and disadvantages of medical imaging techniques

## INTRODUCTORY ACTIVITY

Investigation on the use of medical imaging techniques:

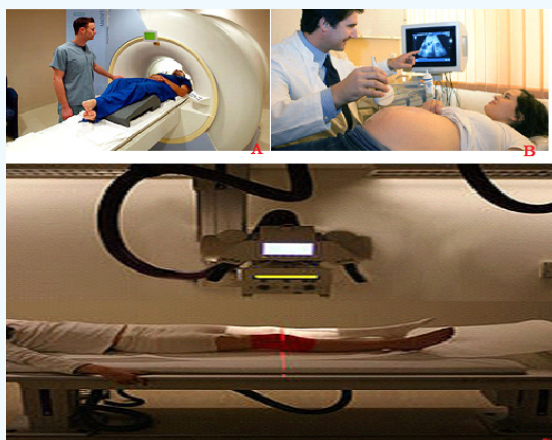

fig.11. 1: Medical imaging techniques

Years ago, the only way to get information from inside of human bodies was through surgery. In modern medicine, medical imaging has undergone major advancements and this ability to obtain information about different parts of the human body has many useful clinical applications.

Using information provided on the above pictures, answer to the following questions:

1. Observe the image A, B, and C (Fig.12.1) and describe what is happening.
2. Suggest the technique that is being used for each image?
3. Explain the working principle of the mentioned techniques in question 2?

### 11.1 X-RAY IMAGING.

#### 11.1.1 Interaction of X-rays with matter.

##### a. Introduction

In unit 10, we learnt that X-rays are electromagnetic radiation produced by focusing a beam of high energy electron on a target material in x-ray tube. Since the major part of the energy of the electrons is converted into heat in the target (only about 1% will appear as X-rays), the target material should have a high melting point and good heat conduction ability. To get a high relative amount of X-ray energy, the anode material should be of high atomic number. Tungsten is the dominating anode material and is in modern X-ray tubes often mixed with Rhenium.

In X-ray diagnostics, radiation that is partly transmitted through and partly absorbed in the irradiated object is utilized. An X-ray image shows the variations in transmission caused by structures in the object of varying thickness, density or atomic composition.

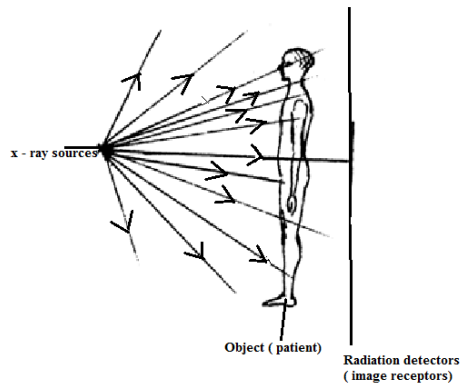

Fig.11.2: The necessary attributes for X-ray imaging are shown: X-ray source, object (patient) and a radiation detector (image receptor).

### ACTIVITY 11.1: Exploration of x-ray image

Analyze the figure below answer to the following questions:

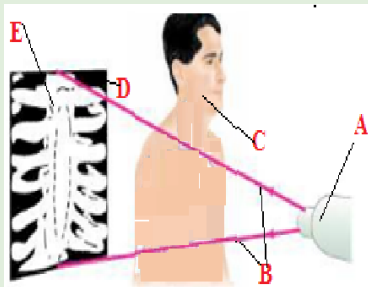
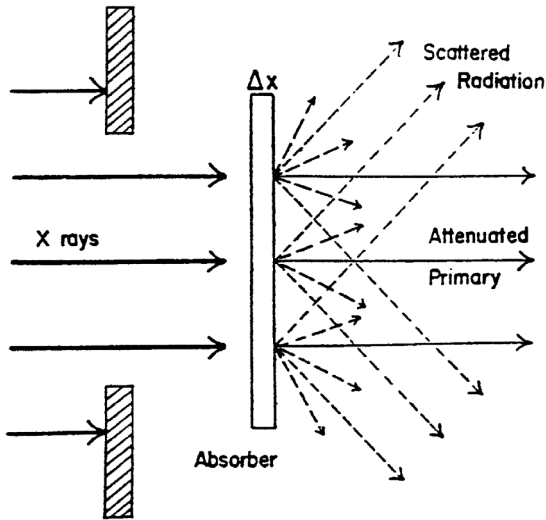

Fig.11.3 procedure of X-ray image formation

1. What do the letters A, B, C, D and E stand for?
2. Explain the process used from A to E.
3. Explain how radiology differ from radiography.

#### b. Attenuation and Absorption of X-rays

There are principally two interaction processes that give rise to the x-ray attenuation (variation in photon transmission) through the patient which is the basis of X-ray imaging. These are photoelectric absorption and scattering processes.



**Fig.11.4:** Attenuation of monoenergetic X-ray photons in a thin layer of a given material

A photon which has experienced an interaction process has either been absorbed or has changed its energy and/or direction of motion. A photon that changes its direction of motion is called a scattered photon. For monoenergetic x-ray photons, the number of photons that experience such interactions and therefore removed from the primary beam when this is incident on a thin layer of material is proportional to the number of incident photons ( $N$ ) and the thickness of the layer ( $dx$ ) following the expression :

$$dN = -\mu N dx \quad (11.01)$$

where  $\mu$  is a constant of proportionality called the linear attenuation coefficient. Integrating the above equation will result in

$$N(x) = N_0 \exp(-\mu x) \quad (11.02)$$

where  $N_0$  is the initial number of photons in the incident beam.

It can be seen that the incident beam photons (or the beam energy) is attenuated exponentially as the X-rays travel through the material. The different interaction processes involved, that are absorption, coherent and incoherent scattering and pair production, add their contributions to the total linear attenuation coefficient

$$\mu = \mu_a + \mu_{coh} + \mu_{incoh} + \mu_p \quad (11.03)$$

where  $\mu_a$ ,  $\mu_{coh}$ ,  $\mu_{incoh}$ , and  $\mu_p$  are the contributions to the attenuation from photoelectric absorption, coherent scattering, incoherent scattering and pair

production.

### C. Contrast

The contrast is a measure of the difference in radiation transmission or other parameters between two adjacent areas in a radiographic image. Contrast plays an important role in the ability of a radiologist to perceive image detail.

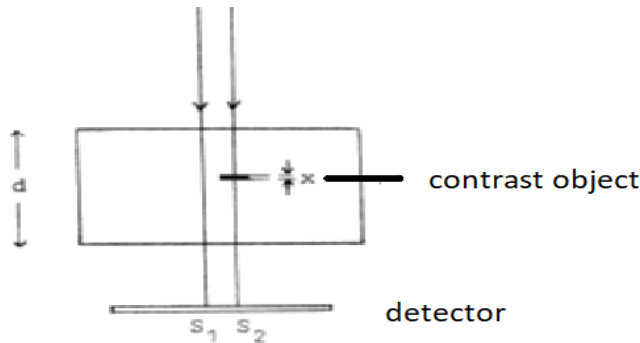

Fig. 12.5: Illustration of the concept of contrast.

The contrast  $C$ , can be estimated as 
$$C = \frac{\varepsilon_1 - \varepsilon_2}{\varepsilon_1} \quad \mathbf{11.04}$$

where  $\varepsilon_1$  and  $\varepsilon_2$  are energies of the monoenergetic X-ray photons per unit area reaching the detector and therefore absorbed in the detector without and with the contrasting detail respectively. In the case where the film is used as image receptor, the signal is obtained in terms of the optical density. The image contrast is then usually defined as the optical density difference beside and behind the contrasting detail.

In such situation where monoenergetic photons are considered and no scattered radiation is reaching the detector, the absorbed energy in the detector can be written as 
$$\varepsilon_1 = \varepsilon_o \exp(-\mu_1 d) \quad \mathbf{(11.05)}$$

Where  $d$ , is the thickness of the object with linear attenuation coefficient  $\mu_1$

The energy through the contrasting detail can be expressed as

$$\varepsilon_2 = \varepsilon_o \exp(-\mu_1(d-x)) \exp(-\mu_2 x) \quad \mathbf{(11.06)}$$

where  $\varepsilon_o$  is the energy absorbed in the detector with no object present,  $x$  is the thickness of the contrasting detail with its linear attenuation coefficient  $\mu_2$ .

Replacing equation 12.05 and 12.06 into equation 12.04 we obtain the contrast

$$c \text{ as, } c = \frac{\varepsilon_1 - \varepsilon_2}{\varepsilon_1} = 1 - \exp(-(\mu_2 - \mu_1) x) \quad (11.07)$$

Expanding  $\exp(-(\mu_2 - \mu_1)x)$ , for small values of  $x$ , reduces to

$$c = (\mu_2 - \mu_1) x \quad (11.08)$$

The contrast is then proportional to the difference in the linear attenuation coefficients and the thickness of the contrasting detail. Therefore, when scattered radiation is neglected in the process, the contrast is independent of the thickness  $d$  of the object but also it does not depend on where in the object the contrasting detail is situated.

The ability of conventional radiography to display a range of organs and structures may be enhanced by the use of various contrast materials, also known as contrast media. The most common contrast materials are based on barium or iodine. Barium and iodine are high atomic number materials that strongly absorb X-rays and are therefore seen as dense white on radiography.

### 11.1.2 X-rays Imaging Techniques

#### a. Conventional Radiography

X-rays are able to pass through the human body and produce an image of internal structures. The resulting image is called a radiograph, more commonly known as an 'X-ray' or 'plain film'. The common terms 'chest X-ray' and 'abdomen X-ray' are widely accepted and abbreviated to CXR and AXR.

As a beam of X-rays passes through the human body, some of the X-rays photons are absorbed or scattered producing reduction or attenuation of the beam with the internal human structure acting as contrasting details.

Therefore tissues of high density and/or high atomic number cause more X-ray beam attenuation and are shown as lighter grey or white on radiographs. Less dense tissues and structures cause less attenuation of the X-ray beam, and appear darker on radiographs than tissues of higher density. The figure below shows the typical conventional radiograph of a human body.

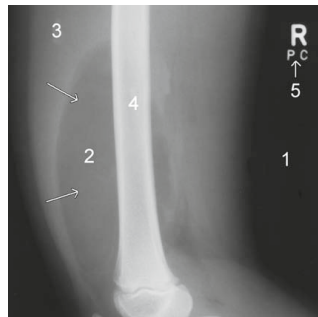

*Fig.11.6*

Fig.11.6: The five principal radiographic densities. This radiograph of a benign lipoma (arrows) in a child's thigh demonstrates the five basic radiographic densities: (1) air; (2) fat; (3) soft tissue; (4) bone; (5) metal. (David A Disle (2012) Imaging for students. Fourth Edition. (Page 1))

Five principal densities are easily recognized on this plain radiograph due to the increase in their densities:

1. Air/gas appears as black, e.g. lungs, bowel and stomach
2. Fat is shown by dark grey, e.g. subcutaneous tissue layer, retroperitoneal fat
3. Soft tissues/water appears as light grey, e.g. solid organs, heart, blood vessels, muscle and fluid-filled organs such as bladder
4. Bone appears as off-white
5. Contrast material/metal: bright white.

In the past, X-ray films were processed in a darkroom or in freestanding daylight processors. In modern practice, radiographic images are produced digitally using one of two processes, computed radiography (CR) and digital radiography (DR).

DR uses a detector screen containing silicon detectors that produce an electrical signal when exposed to X-rays. This signal is analyzed to produce a digital image. Digital images obtained by CR and DR are sent to viewing workstations for interpretation. Images may also be recorded on X-ray film for portability and remote viewing.

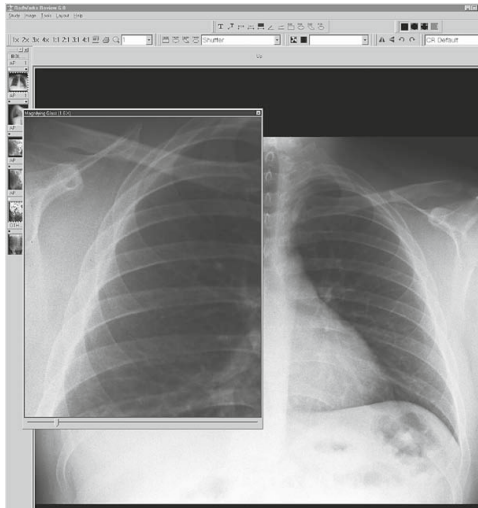

*Fig.11.7:Computer radiography image.*

The image given by a computer radiography may be reviewed and reported on a computer workstation. This allows various manipulations of images as well as application of functions such as measurements of length and angles measurements.

The relative variance of the shadows depends upon the density of the materials within the object or body part. Dense, calcium – rich bone absorbs X-rays to a higher degree than soft tissues that permit more X-rays to pass through them, making X-rays very useful for capturing images of bone.

In projection radiography, there is much room for adjusting the energy level of the X-rays depending on the relative densities of the tissues being imaged and also how deep through a body the waves must travel in order to achieve the imaging.

- Images of bones (for instance, to examine a fracture or for diagnostic measures related to bone conditions like osteoarthritis or certain cancers) require high-energy X-rays because of the high density of bone.
- Images of soft tissues like lungs, heart and breasts (both chest X-rays and mammography are very common diagnostic applications of X-rays) require relatively less energy from the X-rays in order to penetrate properly and achieve excellent images.
- In order to achieve these different energies, technologists use X-ray generators of different voltages and equipped with anodes made of different metals.

## **b. Mammography**

## ACTIVITY 11.2

One day a girl suffering from the breast tells her mother about the problem. And her mother advises her to go to the hospital to consult a doctor.

- Think of the problem that girl may have.
- Try to explain what may be the cause of that problem.
- If you are a doctor how can you detect such problem?
- Which advise can you give to other people who are not suffering fro
- m that problem in order to prevent it?

Mammography is a specialized medical imaging that uses low-dose X-rays to investigate the internal structure of the breast. A mammography exam, called a mammogram, helps in the early detection and diagnosis of women's breast diseases such as breast cancer before even experiencing any symptom. Below is a typical mammography test showing the presence of abnormal areas of density, mass, or calcification that may indicate the presence of cancer.

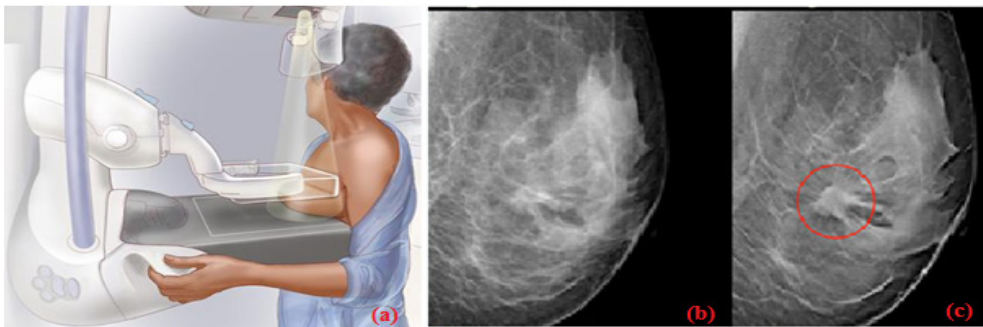

fig.11. 8: Mammography:(a) the breast is pressed between two plates x-rays are used to takes pictures of breast tissues,(b)photographic image of breast tissues, (c)Breast with cancer.

Mammography:(a) the breast is pressed between two plates x-rays are used to takes pictures of breast tissues,(b)photographic image of breast tissues, (c) Breast with cancer. A mammography unit is a rectangular box that houses the tube in which X-rays are produced. The unit is used exclusively for X-ray exams of the breast, with special accessories that allow only the breast to be exposed to the X-rays. Attached to the unit is a device that holds and compresses the breast and positions it so images can be obtained at different angles.

In **conventional film** and **digital mammography**, a stationery X-ray tube captures an image from the side and an image from above the compressed breast.

**Breast tomosynthesis**, also called three-dimensional **(3-D) mammography** and digital breast tomosynthesis (DBT), is an advanced form of breast imaging where multiple images of the breast from different angles are captured and reconstructed (“synthesized”) into a three-dimensional image set. In this way, 3-D breast imaging is similar to computed tomography (CT) imaging in which a series of thin “slices” are assembled together to create a 3-D reconstruction of the body.

### **c. Computer tomography scan (ct scan)**

#### **CT terminology**

In 1970s, a revolutionary new X-ray technique was developed called Computer tomography (CT), which produce an image of a slice through the body. The word tomography comes from the Greek: tomos =slice, graph= picture.)

A computed tomography scan also known as CT scan, makes use of computer-processed combinations of many X-ray measurements taken from different angles to produce cross-sectional (tomographic) images (virtual “slices”) of specific areas of a scanned object, allowing the user to see inside the object without cutting it. Other terms include computed axial tomography (CAT scan) and computer aided tomography. The term “computed tomography” (CT) is often used to refer to X-ray CT, because it is the most commonly known form but many other types of CT exist.

CT is an imaging technique whereby cross-sectional images are obtained with the use of X-rays. In CT scanning, the patient is passed through a rotating gantry that has an X-ray tube on one side and a set of detectors on the other. Information from the detectors is analysed by computer and displayed as a grey-scale image. Owing to the use of computer analysis, a much greater array of densities can be displayed than on conventional X-ray films.

This allows accurate display of cross-sectional anatomy, differentiation of organs and pathology, and sensitivity to the presence of specific materials such as fat or calcium. As with plain radiography, high- density objects cause more attenuation of the X-ray beam and are therefore displayed as lighter grey than objects of lower density.

#### **Principle behind of computer tomography scan (CT scan).**

Computer Tomography is shown in below figure: a thin collimated beam of X- ray(“ to collimate” means to “make straight”) passes through the body to a detector that measures the transmitted intensity. Measurements are made at

a large number of points as the source and detector are moved past the body together. The apparatus is rotated slightly about the body axis and again scanned; this is repeated at  $1^\circ$  intervals for  $180^\circ$ . The intensity of the transmitted beam for the many points of each scan, and for each angles, are sent to a computer that reconstructs the image of the slice. Note that the imaged slice is perpendicular to the long axis of the body. For this reason, CT is sometimes called computerize axial tomography.

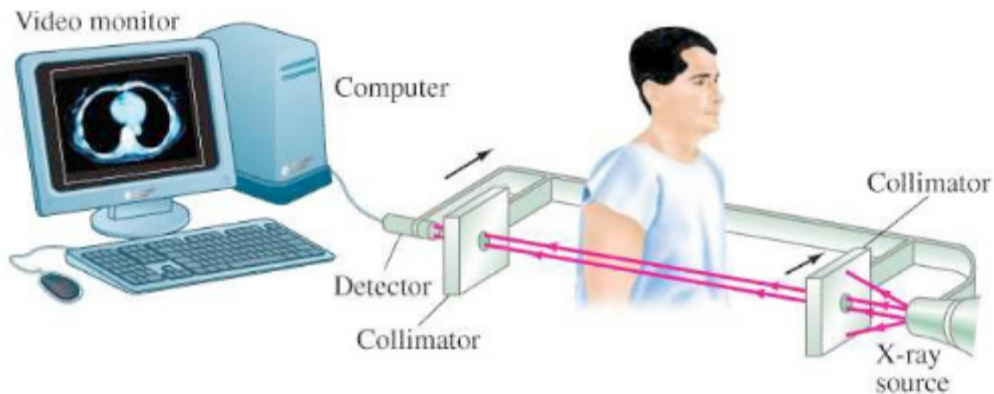

Fig.11. 9: Tomography image

The use of single detector would require a few minutes for many scans needed to form a complete image. Much faster scanner use a fan beam in which passing through the entire cross section of the body are detected simultaneously by many detectors. The x-ray source and the detectors are rotated about the patient and an image requires only few seconds to be seen. This means that rays transmitted through the entire body are measured simultaneously at each angle where the source and detector rotate to take measurements at different angles.

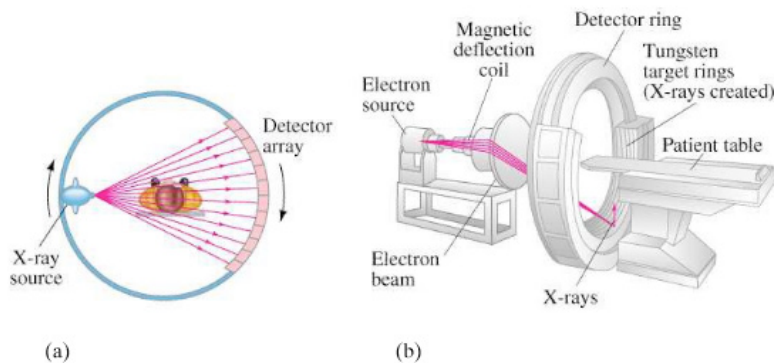

Fig.11. 10: computer tomography scan

CT images of internal organs, bones, soft tissue, and blood vessels provide

greater clarity and more details than conventional X-ray images, such as a chest X-Ray.

### **Function of CT scan**

- A motorized table moves the patient through a circular opening in the CT imaging system.
- While the patient is inside the opening, an X-ray source and a detector assembly within the system rotate around the patient. A single rotation typically takes a second or less. During rotation the X-ray source produces a narrow, fan-shaped beam of X-rays that passes through a section of the patient's body.
- Detectors in rows opposite the X-ray source register the X-rays that pass through the patient's body as a snapshot in the process of creating an image. Many different "snapshots" (at many angles through the patient) are collected during one complete rotation.
- For each rotation of the X-ray source and detector assembly, the image data are sent to a computer to reconstruct all of the individual "snapshots" into one or multiple cross-sectional images (slices) of the internal organs and tissues.

Note that, it is advisable to avoid unnecessary radiation exposure; a medically needed CT scan obtained with appropriate acquisition parameter has benefits that outweigh the radiation risks.

### **11.1.3 Checking my progress**

1. Outline the advantage and disadvantages CT scan
2. Explain the types of x-ray imaging used in mammography.
3. In mammography exams, is the breast compression necessary? Why
4. A beam of X-rays passes through the human body of tissues with different densities; explain the production of X-rays on less dense tissues?

## **11.2 ULTRASONIC IMAGING**

### **11.2.1 Basics of Ultra sound and its production**

#### **ACTIVITY 11.3**

1. Distinguish ultrasound from infrasound?
2. Where do you think ultrasound may be applied in daily life?
3. Advise on how ultrasound be used in medicine?

Sound can refer to either an auditory sensation in the brain or the disturbance in a medium that causes this sensation. Hearing is the process by which the ear transforms sound vibrations into nerve impulses that are delivered to the brain and interpreted as sounds. Sound waves are produced when vibrating objects produce pressure pulses of vibrating air. The auditory system can distinguish different subjective aspects of a sound, such as its loudness and pitch.

Pitch is the subjective perception of the frequency, which in turn is measured in cycles per second, or Hertz (Hz). The normal human audible range extends from about 20 Hz to 20 000 Hz, but the human ear is most sensitive to frequencies of 1 000 Hz to 4 000 Hz. Loudness is the perception of the intensity of sound, related to the pressure produced by sound waves on the tympanic membrane. The pressure level of sound is measured in decibels (dB), a unit for comparing the intensity of a given sound with a sound that is just perceptible to the normal human ear at a frequency in the range to which the ear is most sensitive. On the decibel scale, the range of human hearing extends from 0 dB, which represents the auditory threshold, to about 130 dB, the level at which sound becomes painful.

### ***11.2.2 Interaction of sound waves with different structure inside the body***

#### **a. Introduction**

Ultrasound imaging uses ultra-high-frequency sound waves to produce cross-sectional images of the body. Ultrasound is actually sound with a frequency in excess of 20 kHz, which is the upper limit of human hearing. Typical ultrasound frequencies used for clinical purposes are in the 2 MHz to 10 MHz range.

Different tissues in a human or animal body alter the ultra sound waves in different ways. Some waves are reflected directly while others scatter the waves before they return to the transducer as echoes. The reflected ultrasound pulses detected by the transducer need to be amplified in the scanner or ultrasonic probe. The echoes that come from deep within the body are more attenuated than those from the more superficial parts and therefore required more amplification.

When echoes return to the transducer, it is possible to reconstruct a two dimensional map of all the tissues that have been in the beams. The information is stored in a computer and displayed on a video (television) monitor. Strong echoes are said to be of the high intensity and appear as brighter dots on the screen.

#### **b. Reflection of ultrasound**

When the pulse of ultrasound is sent into the body and meets a boundary between two media, of different specific acoustic impedance  $Z$ , the sound wave needs to change gear in order to continue. If the difference in  $Z$  across the boundary is large the wave cannot easily adjust: there is an “acoustic mismatch”. Most of the wave is reflected and a strong echo is recorded. The fraction of intensity reflected back ( $I_r$ ) to that incident ( $I_i$ ) at the normal incidence, is known as the **intensity of reflection coefficient**

$$\alpha = \frac{I_r}{I_i} \quad (11.09)$$

which in turn reduces deduces to;  $\alpha = \frac{(Z_2 - Z_1)^2}{(Z_2 + Z_1)^2}$  (11.10)

where  $Z$  is acoustic impedance

Note that large difference in  $Z$  give rise to large values for  $\alpha$ , producing strong echoes

### EXAMPLE 11.4

Estimate the percentage of incidence intensity reflected back at fat per muscle boundary.

**Answer:**

we need to calculate the value of  $\alpha$  for the boundary using the equation

$$\alpha = \frac{(Z_2 - Z_1)^2}{(Z_2 + Z_1)^2}$$

with  $Z_1 = 1.38 \times 10^6 \text{ kgm}^{-2} \text{ s}^{-1}$  and  $Z_2 = 1.70 \times 10^6 \text{ kgm}^{-2} \text{ s}^{-1}$

$$\alpha = \frac{(1.70 \times 10^6 - 1.38 \times 10^6)^2}{(1.70 \times 10^6 + 1.38 \times 10^6)^2} = 0.011$$

Hence, 1.1% of the incidence intensity is reflected back.

Ultrasounds are high-frequency sound waves above the human ear’s audible range: that is with frequency sound waves greater than 20 kHz. In fact, the frequencies used in medicine are much higher than this, typically between 1 MHz and 15 MHz. like all sound waves, ultrasound consists of longitudinal, elastic or pressure waves, capable of traveling through solids, liquids and gases. This makes them ideal for penetrating the body, unlike transverse mechanical

waves, which cannot travel to any great extent through fluids.

### c. Attenuation of ultrasound

The attenuation of the waves describes the reduction in its intensity as they travel through a medium. This loss is due to a number of factors:

- The wave simply “spreads out” and suffers an “inverse square law type” reduction in intensity.
- The wave is scattered away from its original direction
- The wave is absorbed in the medium.

The amount of **absorption** of ultrasound beam in a medium is described by the absorption coefficient  $\alpha$ , which is intensity level per unit length. It is expressed in decibels per cm and it firstly depends on the type of medium the wave is propagating into. As example whilst water absorbs very little ultrasound, bone is a strong absorber, putting it at risk, for example, during high- power ultrasound therapy.

Secondly, higher frequencies suffer greater absorption. In fact if the frequency is doubled, the absorption increases by the factor of four. This has very important consequences when choosing the best frequency at which to image the body. If the selected frequency is too high, the ultrasound will not be able to penetrate to the regions under investigation.

#### *11.2.3 Ultrasonic imaging techniques*

The basic component of the ultrasound probe is the piezoelectric crystal. Excitation of this crystal by electrical signals causes it to emit ultra-high-frequency sound waves; this is the piezoelectric effect. The emitted ultrasound waves are reflected back to the crystal by the various tissues of the body. These reflected sound waves also called the “**echoes**” act on the piezoelectric crystal in the ultrasound probe to produce an electric signal, again by the piezoelectric effect. It is this electric signal which is analysed by a computer produces a cross-sectional image.

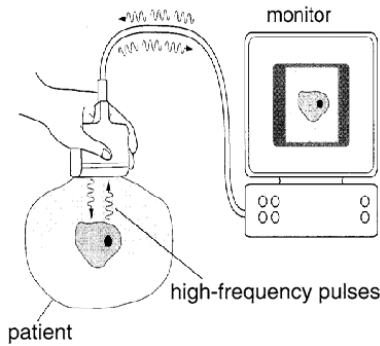

Fig.11.11: Typical set up of ultrasound system

The process of imaging is the same as the echo-locating sonar of a submarine or a bat. The observer sends out a brief pulse of ultrasound and waits for an echo. The pulse travels out, reflects off the target and returns. The ultrasound machine uses pulses because the same device acts as both transmitter and receiver. If it continually sent out sounds, then the receiver would not hear the much softer echo over the louder transmission.

The duty cycle of the ultrasound imager is the amount of time spent transmitting compared to the total time of transmitting and listening.

Sonar is an acronym for Sound Navigation and Ranging. It relies on the reflection of ultrasound pulses. A short pulse of ultrasound is directed towards the object interest, which then reflects it back as an echo. The total time  $t$  between transmission of pulse and reception of an echo is measured, often using a cathode ray oscilloscope (CRO). The sonar principle is used to estimate the depth of a structure, using

$$d = \frac{vt}{2} \tag{11.11}$$

Where  $t$  is the time taken to go and back and  $v$  is the velocity of ultrasound in the medium.

The factor of 2 is necessary because the pulse must travel “there and back”

An ultrasound beam structure is directly into the body. The reflection or echoes from different body structure are then detected and analyzed, yielding information about the locations. For example if the time delays between the reception of echo pulse 1 and 2 (**Fig.11.12 below**) is  $t$ , then the diameter of the baby’s head can be found using the above formula.

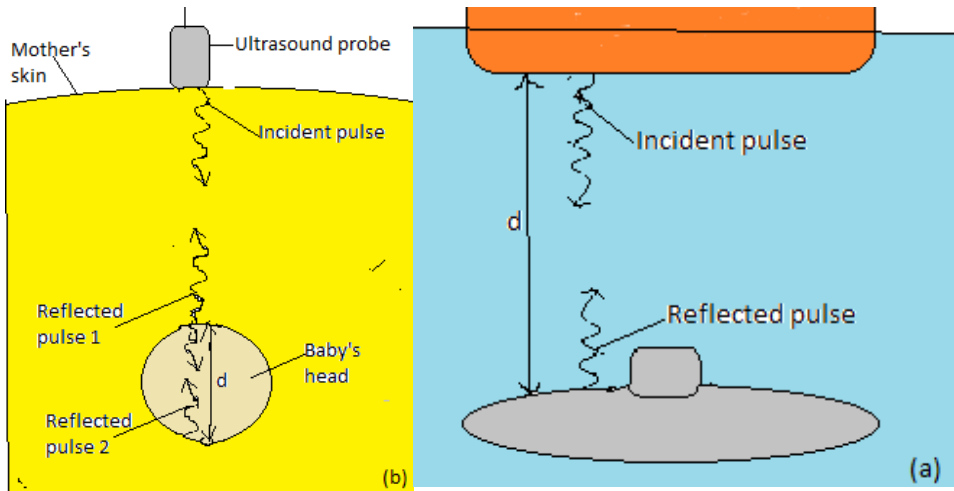

Fig.11. 12: Echo location: (a) conventional sonar; (b) medical imaging

During an investigation using ultrasound, the time delay for an echo to return from a structure is  $10.5\mu s$ . If the average velocity of ultrasound in the eye is  $1510\text{ m/s}$ . Calculate the depth of the structure.

$$d = \frac{1510\text{ m s}^{-1} \times 10.5 \times 10^{-6}\text{ s}}{2} = 7.93 \times 10^{-3}\text{ m} = 7.93\text{ mm}$$

### a. Doppler ultrasonic

An object travelling towards the listener causes sound waves to be compressed giving a higher frequency; an object travelling away from the listener gives a lower frequency. The Doppler effect has been applied to ultrasound imaging. Flowing blood causes an alteration to the frequency of sound waves returning to the ultrasound probe. This frequency change or shift is calculated allowing quantization of blood flow. The combination of conventional two-dimensional ultrasound imaging with Doppler ultrasound is known as Duplex ultrasound.

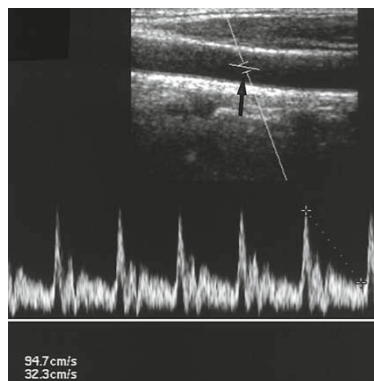

Fig.11.13: Duplex ultrasound.

The Doppler sample gate is positioned in the artery (arrow) and the frequency shifts displayed as a graph. Peak systolic and end diastolic velocities are calculated and also displayed on the image in centimeters per second.

As ultrasound imaging uses sound waves to produce pictures of inside of the body. It is used to help diagnose the cause of pain, swelling and infection in the body's internal organs and to examine a baby in pregnant woman and the brain and hips in infants. It is also used to help guide biopsies, diagnose heart conditions and assess damage after a heart attack.

Ultrasound examinations do not use ionizing radiation (x-rays), there is no radiation exposure to the patient. Because ultrasound image are captured in real time, they can show the structure and movement of the body's internal organs, as well as blood flowing through blood vessels.

### **b. Advantages and Disadvantages of ultrasounds**

The advantages of ultrasound over other imaging modalities include:

- Lack of ionizing radiation.
- Relatively low cost
- It is noninvasive (of medicine procedures not involving the introduction of instruments into the body)
- Quick procedure
- Good for examining soft tissues.
- Portability of equipment.

Some disadvantages of ultrasound include:

- It is highly operator dependent as it relies on the operator to produce and interpret images at the time of examination
- Not as much details as X-rays and MRI
- It cannot be used in areas that contain gas (such as lungs)
- Doesn't pass through bones.
- Can be wrong in detecting physical abnormalities.

### 11.2.4 Checking my progress

1. Explain how ultrasound imaging is used?
2. Who take the decision to scan or not to scan in normal pregnancy?
3. What are the risks and side effects to the mother or baby during ultrasound?
4. If an ultrasound is done at 6 to 7 weeks and a heartbeat is not detected, does

## 11.3 SCINTIGRAPHY (NUCLEAR MEDICINE)

### ACTIVITY 11.4

- a. What do you understand by 'radionuclide imaging'?
- b. What is a radionuclide scan used for?
- c. Compare radionuclide scan with mammography scan?

### 11.3.1 Physics of scintigraphy and terminology

**Scintigraphy** refers to the use of gamma radiation to form images following the injection of various radiopharmaceuticals. The key word to understanding of scintigraphy is radiopharmaceutical. 'Radio' refers to the radionuclide, i.e. the emitter of gamma rays.

The most commonly used radionuclide in clinical practice is technetium, written in this text as  $mTc$ , where 99 is the atomic mass, and the 'm' stands for metastable. Metastable means that the technetium atom has two basic energy states: high and low energy states. As the technetium transforms from the high-energy state to the low-energy state, it emits a quantum of energy in the form of a gamma ray, which has energy of 140 keV. Other commonly used radionuclides include gallium citrate ( $^{67}Ga$ ), thallium ( $^{201}Tl$ ), indium ( $^{111}In$ ) and iodine ( $^{131}I$ ).

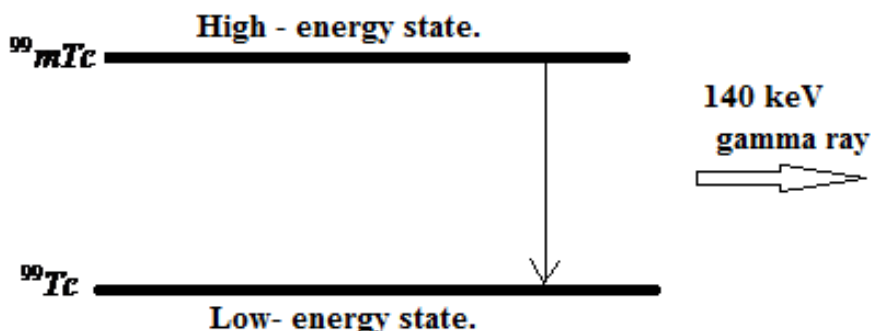

Fig.11.14: Gamma ray production. The metastable atom  $^{99m}Tc$  passes from a high-energy to a low-energy state and releases gamma radiation with a peak energy of 140 keV.

### 11.3.2 Basic functioning of radionuclide scan

#### ACTIVITY 11.5

For radionuclide imaging, it is advisable for the patient to consume a small quantity of radionuclide, or it is injected into a vein in your arm.

- a. How long does it take?
- b. What is the purpose of those radionuclide chemicals?
- c. Assuming the patient has already consumed the radionuclide for him/her to be scanned and wants to take another scan on another part of the body, will the patient be required to take another dose of the nuclide?
- d. You as a student, what advice can you give to a patient who develops allergies after taking the radio nuclear chemical?

A **radionuclide** scan is a way of **imaging** bones, organs and other parts of the body by using a small dose of a radioactive chemical. There are different types of **radionuclide** chemical. The one used depends on which organ or part of the body need to be scanned.

A radionuclide (sometimes called a radioisotope or isotope) is a chemical which emits a type of radioactivity called gamma rays. A tiny amount of radionuclide is put into the body, usually by an injection into a vein. Sometimes it is breathed in, or swallowed, or given as eye drops, depending on the test.

Gamma rays are similar to X-rays and are detected by a device called a gamma camera. The gamma rays which are emitted from inside the body are detected by the gamma camera, are converted into an electrical signal and sent to a computer. The computer builds a picture by converting the differing intensities of radioactivity emitted into different colors or shades of grey.

However, radionuclide imaging techniques do not depict structural anatomy like ultrasound, X-ray computed tomography (XCT) or conventional radiographs. It is the only established noninvasive technique available to investigate organ physiology, although recently Nuclear magnetic resonance (NMR) imaging technique has shown its capability to probe organ physiology and anatomy without ionizing radiation.

Radionuclide scans do not generally cause any after effects. Through the natural process of radioactive decay, the small amount of radioactive chemical in your body will lose its radioactivity over time. Although the levels of radiation used in the scan are small, patients may be advised to observe special precautions.

### 11.3.3 Limitations and disadvantages of scintigraphy

The main advantages of scintigraphy are its high sensitivity and the fact that the functional information is provided as well as anatomical information. However it has some disadvantages that are listed below:

- i. Generally poor resolution compared with other imaging techniques.
- ii. Radiation risks due to the administered radionuclide
- iii. Can be invasive, sometimes requiring an injection into the bloodstream
- iv. Disposal for radioactive waste, including that from patients, requires special procedures.
- v. Relatively high costs associated with radiotracer production and administration.

### 11.3.4 Checking my progress

Choose the correct answers

1. Scintigraphy refers to the use of:
  - a. Gamma radiation to form images
  - b. X- ray radiation to form images
  - c. X- rays and gamma radiations to form images
  - d. None of radiation to form images.
2. The radionuclide in clinical practice are
  - a. Technetium
  - b. Thallium
  - c. Gallium
  - d. ALL of them

## 11.4 MAGNETIC RESONANCE IMAGING (MRI)

### ACTIVITY 11.6: Principles of MRI

1. What does MRI mean?
2. What is it used for?
3. What makes MRI to be powerful compared to other imaging techniques?
4. is it advisable for a pregnant woman to be placed in MRI Scanner? Explain your view?

### 11.4.1. MRI physics and terminology.

Magnetic resonance (MR) imaging has become the dominant clinical imaging modality with widespread, primarily noninvasive, applicability throughout the body and across many disease processes. The progress of MR imaging has been rapid compared with other imaging technologies and it can be attributed in part to physics and in part to the timing of the development of MR imaging, which corresponded to an important period of advances in computing technology.

Initially let us described how magnetic resonance can be demonstrated with a pair of magnets and a compass. If a compass happens to find itself near a powerful magnet, the compass needle will align with the field. In a normal pocket compass, the needle is embedded in liquid to dampen its oscillations. Without liquid, the needle will vibrate through the north direction for a period before coming to rest. The frequency of the oscillations depends on the magnetic field and of the strength of the magnetic needle.

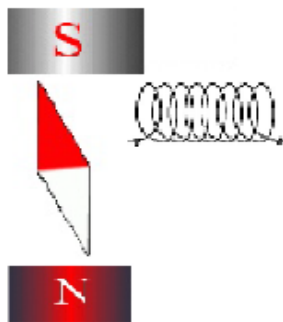

Figure 11.15: small coil placed to the magnetic needle

Let us focus on what made the needle oscillate. It was the small movements of the magnet, back and forth, or more precisely the oscillation of a weak magnetic field perpendicular to the powerful stationary magnetic field caused by the movement of the magnet. But oscillating magnetic field is what we understand by “radio waves”, which means that in reality, we could replace the weak magnet with other types of radio wave emitters.

This could, for example, be a small coil subject to an alternating current, as shown in figure above. Such a coil will create a magnetic field perpendicular to the magnetic needle. The field changes direction in synchrony with the oscillation of the alternating current, so if the frequency of the current is adjusted to the resonance frequency of the magnetic needle, the current will set the needle in motion. This is also applied in an MR scanner. In summary, the needle can be set in motion from a distance by either waving a magnet or by applying an alternating current to a coil. In both situations, magnetic resonance is achieved

when the magnetic field that motion or alternating currents produce, oscillates at the resonance frequency. When the waving or the alternating current is stopped, the radio waves that are subsequently produced by the oscillating needle will induce a voltage over the coil.

MRI uses the magnetic properties of spinning hydrogen atoms to produce images. The first step in MRI is the application of a strong, external magnetic field. For this purpose, the patient is placed within a large powerful magnet. Most current medical MRI machines have field strengths of 1.5 or 3.0 Tesla. The hydrogen atoms within the patient align in a direction either parallel or antiparallel to the strong external field.

A greater proportion aligns in the parallel direction so that the net vector of their alignment, and therefore the net magnetic vector, will be in the direction of the external field. This is known as longitudinal magnetization. A second magnetic field is applied at right angles to the original external field. This second magnetic field is known as the radiofrequency pulse (RF pulse), because it is applied at a frequency in the same part of the electromagnetic spectrum as radio waves. A magnetic coil, known as the RF coil, applies the RF pulse.

The RF pulse causes the net magnetization vector of the hydrogen atoms to turn towards the transverse plane, i.e. a plane at right angles to the direction of the original, strong external field. The component of the net magnetization vector in the transverse plane induces an electrical current in the RF coil. This current is known as the MR signal and is the basis for formation of an image. Computer analysis of the complex MR signal from the RF receiver coils is used to produce an MR image.

### ***11.4.2. The magnetism of the body***

Let's see how magnet needles with and without spin are affected by radio waves, we now turn to the "compass needles" in our own bodies.

- a. Most frequently, the MR signal is derived from hydrogen nuclei (meaning the atomic nuclei in the hydrogen atoms). Most of the body's hydrogen is found in the water molecules. Few other nuclei are used for MR.
- b. Hydrogen nuclei (also called protons) behave as small compass needles that align themselves parallel to the field.
- c. The compass needles (the spins) are aligned in the field, but due to movements and nuclear interactions in the soup, the alignment only happens partially.
- d. The nuclei in the body move among each other (thermal motion) and the net magnetization in equilibrium is thus temperature dependent.

- e. Due to the number of hydrogen nuclei (about  $10^{27}$ ) found in the body, the net magnetization still becomes measurable. It is proportional to the field: A large field produces a high degree of alignment and thus a large magnetization and better signal to noise ratio.

### **11.4.3. Magnetic Resonance Imaging (MRI).**

In MRI, a particular type of nucleus is selected and its distribution in the body is monitored. Hydrogen is the most commonly imaged element, not only due to its abundance in the body but also because it gives the strongest MRI signals.

The technique uses a very powerful magnet to align the nuclei of atoms inside the body, and a variable magnetic field that causes the atoms to resonate, a phenomenon called nuclear magnetic resonance. The nuclei produce their own rotating magnetic fields that a scanner detects and uses to create an image.

MRI is used to diagnose a variety of disorders, such as strokes, tumors, aneurysms, spinal cord injuries, multiple sclerosis and eye or inner ear problems. It is also widely used in research to measure brain structure and function, among other things.



*Fig: 11.16: showing a patient entering a MRI set up for exam.*

An MRI scan can be used to examine almost any part of the body, including the:

- Brain and spinal cord
- Bones and joints
- Breasts
- Heart and blood vessels
- Internal organs, such as the liver, womb or prostate gland ,etc

The results of an MRI scan can be used to help diagnose conditions, plan treatments and assess how effective previous treatment has been.

#### 11.4.4. Functional of MRI Scan

### ACTIVITY 11.7

- a. Explain the function of MRI Scan.
- b. What are the advantages and disadvantages of MRI Scan?
- c. What are the hazards associated with MRI?

There are many forms of MRI, some of them are:

#### a. Diffusion-weighted imaging.

Diffusion-weighted imaging (DWI) is sensitive to the random Brownian motion (diffusion) of water molecules within tissue. The greater the amount of diffusion, the greater the signal loss on DWI. Areas of reduced water molecule diffusion show on DWI as relatively high signal. **Diffusion-weighted imaging is the most sensitive imaging test available for the diagnosis of acute cerebral infarction.** With the onset of acute ischaemia and cell death there is increased intracellular water (cytotoxic oedema) with restricted diffusion of water molecules. An acute infarct therefore shows on DWI as an area of relatively high signal.

#### b. Perfusion-weighted imaging

In perfusion-weighted imaging (PWI) the brain is rapidly scanned following injection of a bolus of contrast material (gadolinium). The data obtained may be represented in a number of ways including maps of regional cerebral blood volume, cerebral blood flow, and mean transit time of the contrast bolus. PWI may be used in patients with cerebral infarct to map out areas of brain at risk of ischaemia that may be salvageable with thrombolysis.

#### c. Magnetic resonance spectroscopy

Magnetic resonance spectroscopy (MRS) uses different frequencies to identify certain molecules in a selected volume of tissue, known as a voxel. Following data analysis, a spectrographic graph of certain metabolites is drawn. Metabolites of interest include lipid, lactate, NAA (N-acetylaspartate), choline, creatinine, citrate and myoinositol.

Uses of MRS include characterization of metabolic brain disorders in children, imaging of dementias, differentiation of recurrent cerebral tumour from radiation necrosis, and diagnosis of prostatic carcinoma.

#### **d. Blood oxygen level-dependent imaging**

Blood oxygen level-dependent (BOLD) imaging is a non-invasive functional MRI (fMRI) technique used for localizing regional brain signal intensity changes in response to task performance. BOLD imaging depends on regional changes in concentration of deoxyhemoglobin, and is therefore a tool to investigate regional cerebral physiology in response to a variety of stimuli. BOLD fMRI may be used prior to surgery for brain tumor or arteriovenous malformation (AVM), as a prognostic indicator of the degree of postsurgical deficit.

#### **11.4.5 Advantage and disadvantages of MRI.**

##### **Advantages of MRI in clinical practice include:**

1. Excellent soft tissue contrast and characterization
2. Lack of ionizing radiation.
3. Noninvasive machine.
4. Lack of artefact from adjacent bones, e.g. pituitary fossa

##### **Disadvantages of MRI:**

1. High capital and running costs.
2. Image selected and interpretation is complex.
3. Examination can be difficult for some people who are claustrophobic
4. The examination is noisy and takes long.
5. Hazards with implants, particularly pacemakers.
6. Practical problems associated with large superconducting magnets.

#### **11.4.7. Checking my progress**

1. What is meant by relaxation in the context of MRI?
2. Give the reasons why the hydrogen nucleus is most used in MRI.
3. What does NMR stand for? Explain carefully the role of the three terms involved
4. Draw the basic steps in the formation of MRI image.

### **11.5 ENDOSCOPY**

#### **ACTIVITY 11.8**

1. How can we examine inside the stomach by using light rays?
2. How is endoscope performed?

### 11.3.1 Description

Endoscopy is a nonsurgical procedure used to examine a person's digestive tract. Using an endoscope, which is a flexible tube with a light and camera attached to it, the specialist can view pictures of your digestive tract on a monitor.

During an upper endoscopy, an endoscope is easily passed through the mouth and throat and into the esophagus, allowing the specialist to view the esophagus, stomach, and upper part of the small intestine. Similarly, endoscopes can be passed into the large intestine (colon) through the rectum to examine this area of the intestine.

### 11.3.2 Upper endoscopy

Upper Endoscopy (also known as gastroscopy, EGD, or esophagogastroduodenoscopy) is a procedure that enables your surgeon to examine the lining of the esophagus (swallowing tube), stomach and duodenum (first portion of the small intestine). A bendable, lighted tube about the thickness of your little finger is placed through your mouth and into the stomach and duodenum.

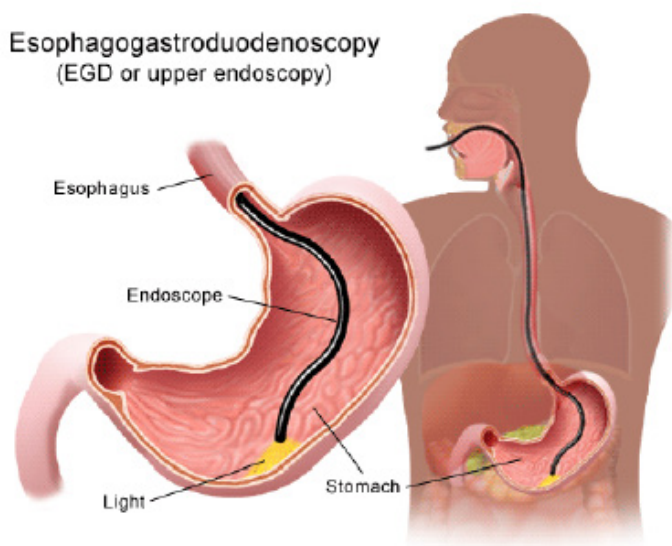

Fig.12.17 Endoscopy exam

### 11.3.3. How is the upper endoscopy performed?

Upper endoscopy is performed to evaluate symptoms of persistent upper abdominal pain, nausea, vomiting, difficulty swallowing or heartburn. It is an excellent method for finding the cause of bleeding from the upper gastrointestinal tract. It can be used to evaluate the esophagus or stomach after major surgery.

It is more accurate than X-rays for detecting inflammation, ulcers or tumors of the esophagus, stomach and duodenum. Upper endoscopy can detect early cancer and can distinguish between cancerous and noncancerous conditions by performing biopsies of suspicious areas.



*Fig.11.18: Interior of a stomach*

A variety of instruments can be passed through the endoscope that allows the surgeon to treat many abnormalities with little or no discomfort, remove swallowed objects, or treat upper gastrointestinal bleeding. Safe and effective control of bleeding has reduced the need for transfusions and surgery in many patients.

#### **11.3.4. Advantages and disadvantages of endoscopy**

##### **Advantages**

- Complete visualization of the entire stomach or digestive tract.
- It is very safe and effective tool in diagnosis
- Does not leave any scar because it uses natural body openings.
- It is cost effective and has low risk
- They are generally painless.
- Can do therapeutic interventions
- Allows for sampling/biopsying of small bowel mucosa
- Allows for resection of polyps.

##### **Disadvantages:**

- Although the endoscope is very safe; however, the procedure has a few potential complications which may include:
- Bleeding
- Perforation (tear in the gut wall)
- Infection
- Reaction to sedation (action of administering a sedative drug to produce a state of calm or sleep).
- Technically difficult procedure
- Very time consuming (Procedure can take > 3 hours)
- Patient may need to be admitted to the hospital

- Higher risk of small bowel perforation
- Case reports of pancreatitis and intestinal necrosis
- Reported incidents of aspiration and pneumonia

### **11.3.5 Checking my progress**

1. What are instruments used to view the esophagus, stomach and upper small intestine of human body?
2. Explain the function of endoscope.
3. Compare and contrast colonoscopy and gastroscopy

### **11.3.6. hazards associated with medical imaging**

The following are some hazards associated with medical imaging:

1. Exposure to ionizing radiation
2. Anaphylactoid reactions to iodinated contrast media
3. Contrast-induced nephropathy (CIN)
4. MRI safety issues
5. Nephrogenic systemic sclerosis (NSF) due to Gd-containing contrast media.

#### **1. Exposure to ionizing radiation**

Radiation effects and effective dose Radiography, scintigraphy and CT use ionizing radiation. Numerous studies have shown that ionizing radiation in large doses is harmful. The risks of harm from medical radiation are low, and are usually expressed as the increased risk of developing cancer as a result of exposure. Radiation effects occur as a result of damage to cells, including cell death and genetic damage. Actively dividing cells, such as are found in the bone marrow, lymph glands and gonads are particularly sensitive to radiation effects.

#### **2. Anaphylactoid contrast media reactions**

Most patients injected intravenously with iodinated contrast media experience normal transient phenomena, including a mild warm feeling plus an odd taste in the mouth. With modern iodinated contrast media, vomiting at the time of injection is uncommon. More significant adverse reactions to contrast media may be classified as mild, intermediate or severe anaphylactoid reactions:

- Mild anaphylactoid reactions: mild urticaria and pruritis
- Intermediate reactions: more severe urticaria, hypotension and mild bronchospasm
- Severe reactions: more severe bronchospasm, laryngeal oedema, pulmonary oedema, unconsciousness, convulsions, pulmonary collapse and cardiac arrest.

### 3. Contrast-induced nephropathy

Contrast-induced nephropathy (CIN) refers to a reduction of renal function (defined as greater than 25 per cent increase in serum creatinine) occurring within 3 days of contrast medium injection. Risk factors for the development of CIN include:

Pre-existing impaired renal function, particularly diabetic nephropathy, Dehydration, Sepsis, Age > 60 years, Recent organ transplant, Multiple myeloma.

The risk of developing CIN may be reduced by the following measures:

Risk factors should be identified by risk assessment questionnaire.

- Use of other imaging modalities in patients at risk including US or non-contrast-enhanced CT.
- Use of minimum possible dose where contrast medium injection is required.
- Adequate hydration before and after contrast medium injection.
- Various pretreatments have been described, such as oral acetylcysteine; however, there is currently no convincing evidence that anything other than hydration is beneficial.

### 4. MRI safety issues

Potential hazards associated with MRI predominantly relate to the interaction of the magnetic fields with metallic materials and electronic devices. Ferromagnetic materials within the patient could possibly be moved by the magnetic field causing tissue damage. Common potential problems include metal fragments in the eye and various medical devices such as intracerebral aneurysm clips. Patients with a past history of penetrating eye injury are at risk for having metal fragments in the eye and should be screened prior to entering the MRI room with radiographs of the orbits. The presence of electrically active implants, such as cardiac pacemakers, cochlear implants and neurostimulators, is generally a contraindication to MRI unless the safety of an individual device is proven.

### 5. Nephrogenic systemic sclerosis

Nephrogenic systemic sclerosis (NSF) is a rare complication of some Gd-based contrast media in patients with renal failure. Onset of symptoms may occur from one day to three months following injection. Initial symptoms consist of pain, pruritis and erythema, usually in the legs. As NSF progresses there is thickening of skin and subcutaneous tissues, and fibrosis of internal organs including heart, liver and kidneys. Identifying patients at risk, including patients with known renal disease, diabetes, hypertension and recent organ transplant,

may reduce the risk of developing NSF following injection of Gd- based contrast media.

### **Risk reduction in MRI**

A standard questionnaire to be completed by the patient prior to MRI should cover relevant factors such as:

- Previous surgical history
- Presence of metal foreign bodies including aneurysm clips, etc.
- Presence of cochlear implants and cardiac pacemakers
- Possible occupational exposure to metal fragments and history of penetrating eye injury
- Previous allergic reaction to Gd-based contrast media
- Known renal disease or other risk factors relevant to NSF.

## END UNIT ASSESSMENT 11

Part I: Copy the following in your notebook and chose the correct answer

1. Which are included in the system components of gamma rays camera for producing image of the body?
  - a. Collimator
  - b. Scintillation
  - c. Attenuation
  - d. All of the above
  
2. Which of the following modalities does not use a form of ionizing radiation?
  - a. Radiography.
  - b. Computed tomography.
  - c. Sonography.
  - d. Magnetic resonance imaging
  
3. Hazards not associated with modern medical imaging include:
  - a. Anaphylactoid reactions to iodinated contrast media
  - b. Complication of some Gd-based contrast media in patients with renal failure.
  - c. Imaging of the breast improves a physician's ability to detect small tumors
  - d. Radiation effects and effective dose Radiography.
  
4. Medical imaging systems are often evaluated the characteristics which are directly related to:
  - a. Image noise.
  - b. Image blurring.
  - c. Image unsharpness.
  - d. Visibility of anatomical detail.
  
5. Risks associated with radionuclide imaging are:
  - a. Generally poor resolution compared with other imaging modalities.
  - b. Rarely receiving an overdose of chemical injected in the vein of the body.
  - c. High capital and running costs
  - d. None of them.

## Part II: Structured questions

6. Write the missing word or words on the space before each number.

The term ..... is often used to refer to X-ray CT.

- a. Gastroscopy is a procedure that enables your surgeon to examine the lining of the .....
  - b. The most sensitive imaging test available for the diagnosis of acute cerebral infarction is .....
  - c. Array of ..... to transform the flashes into amplified electrical pulses inside the body.
  - d. Transducers used are different depending on ..... of a patient, one has 5 MHz and other 3.5 MHz.
  - e. Hydrogen nuclei (also called protons) behave as small ..... that align themselves parallel to the field.
  - f. In ..... there are appearance three words: nuclear, magnetic and resonance.
  - g. Examination can be ..... is one of the disadvantages of MRI.
7. Answer by True if it is True and by False if it is False
- a. The use of gamma radiation to form images following the injection of various radiopharmaceuticals is known as Scintigraphy.
  - b. This decision to scan or not to scan a normal pregnancy must be made only by the photographer. There are universally accepted guidelines at present.
  - c. Tissue in the body absorbs and scatters ultrasound in the same ways. Lower frequencies are more rapidly absorbed (attenuated) than higher frequencies.
  - d. Upper endoscopy uses light and camera to view the esophagus, stomach, and upper part of the small intestine.
  - e. Ultrasound is both generated and detected through high frequency oscillations in piezoelectric crystals so there is ionizing radiation exposure associated with ultrasound imaging.
8. Compare endoscopy imaging and radionuclide imaging
9. What are the advantages of MRI in clinical practice?
10. Is ultrasound safe? explain.
11. What areas of the body can be imaged by ultrasound?
12. Why is ultrasound used in pregnancy?
13. Explain the advantage of CT scan
14. In mammography exams, is the breast compression necessary? Why

### Essay question

Historically, MRI began in the central nervous system, but it is now extended to all regions of the human body. The excellent resolution and contrast available in any chosen plane in the body, makes the MRI an invaluable diagnostic tool with which to study body structure, function and chemistry, as well as disease. Discuss the application of MRI.

# UNIT 12

## RADIATIONS AND MEDICINE

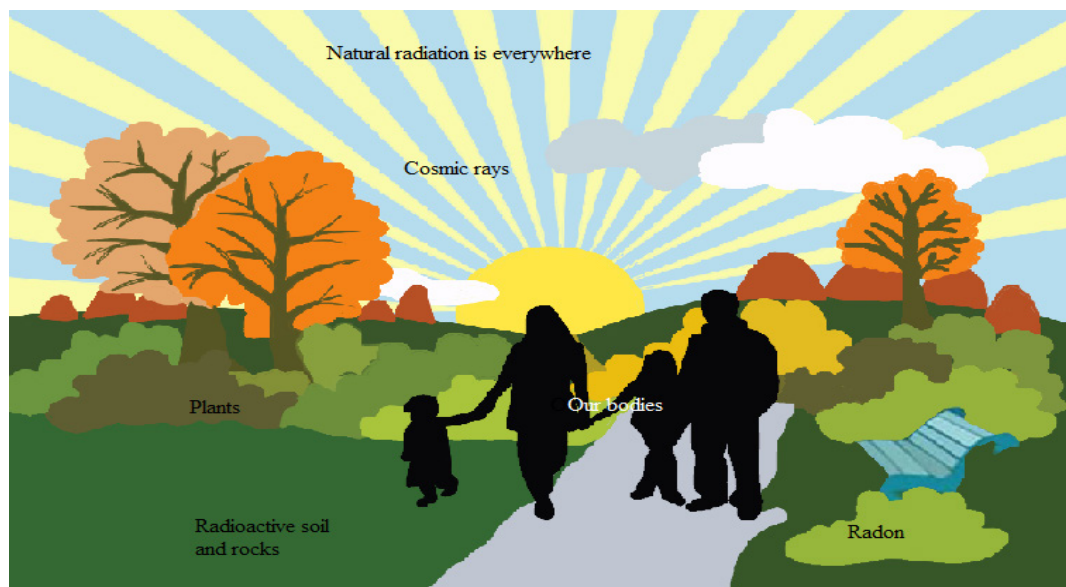

*Fig.13. 1 Various sources of radiation.*

**Key unit Competence:** Analyze the use of radiation in medicine.

### My goals

- Explain radiation dosimetry.
- Differentiate the terms exposure, absorbed dose, quality factor (relative to biological effectiveness) and dose equivalent as used in radiation dosimetry.
- Differentiate physical half-life, biological half-life and effective half-life
- Solve radiation dosimetry problems
- Analyse the basics of radiation therapy for cancer.
- Explain safety precautions when handling radiations
- Describe the concept of balanced risk.

## INTRODUCTORY ACTIVITY

Radiation has always been present and is all around us. Life has evolved in a world containing significant levels of ionizing radiation. Our bodies are adapted to it.

People are constantly exposed to small amounts of ionizing radiation from the environment as they carry out their normal daily activities; this is known as background radiation. We are also exposed through some medical treatments and through activities involving radioactive material.

Fig 13.1 above identifies four major sources of public exposure to natural radiation: cosmic radiation, terrestrial radiation, inhalation and ingestion.

Brainstorm and try to answer the following questions:

- Distinguish artificial source of radiation and natural source of radiation?
- Explain briefly each major source of public exposure to natural radiation stated above.
- Which kind of sources of radiation are mostly preferred to be used in medicine? Explain why
- Does exposure to heavy ions at the level that would occur during deep-space missions of long duration pose a risk to the integrity and function of the central nervous system? Explain to support your idea.

## 12.1 RADIATION DOSE

### 12.1.1 Ionization and non-ionization radiations

#### ACTIVITY 12.1:Types of radiation

Radiation is the emission of particles or electromagnetic waves from a source. Radiation from radioactive materials has the ability to interact with atoms and molecules of living objects.

- With the help of the diagram below, distinguish the forms of radiation?
- Which type do you think is mostly used in medical treatment? Explain your answer with supporting arguments?
- Suggest the possible side effects of using radiations in medicine? Which of the two forms of radiation induces more side effects when exposed to human body? Explain to support your choice.

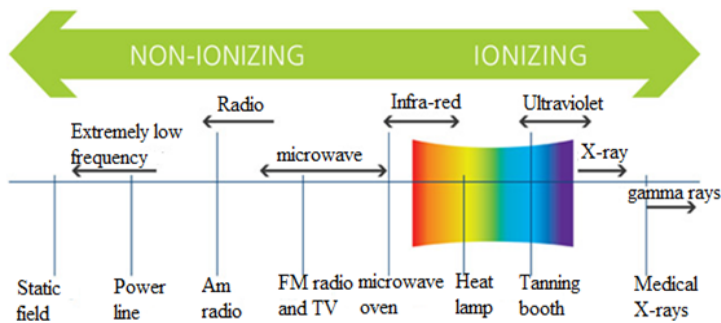

Fig.12. 2: Forms of radiation

In a neutral atom, the positive charge of the nucleus is equal and opposite to the total negative charge of the orbital electrons. If such an atom loses or gains an electron, it becomes an ion. The atom will now have a net positive or negative charge and is called an ion. This process is called ionization, and the radiation responsible for it is called **ionising radiation**. When discussing the interaction of radiations with matter in particularly in relation to health, two basic types of radiation can be considered:

### a. Ionizing radiation.

This is a radiation that carries enough energy to liberate electrons from atoms or molecules, thereby ionizing them. As the more powerful form of radiation, ionizing radiation is more likely to damage tissue than non-ionizing radiation. The main source of exposure to **ionizing radiation** is the radiation used during **medical exams** such as X-ray radiography or computed tomography scans.

However, the amounts of radiation used are so small that the risk of any damaging effects is minimal. Even when radiotherapy is used to treat cancer, the amount of ionizing radiation used is so carefully controlled that the risk of problems associated with exposure is tiny. All forms of living things emit a certain amount of radiation, with humans, plants and animals accumulating radioisotopes as they ingest food, air and water. Some forms of radiation such as potassium-40 emit high-energy rays that can be detected using measurement systems. Together with the background radiation, these sources of internal radiation add to a person's total radiation dose.

Background radiation is emitted from both naturally occurring and man-made sources. Natural sources include cosmic radiation, radon radiation in the body, solar radiation and external terrestrial radiation. Man-made forms of radiation are used in cancer treatment, nuclear facilities and nuclear weapons. Globally, the average exposure to ionizing radiation per year is around 3 milliSieverts (mSv), with the main sources being natural (around 80%). The remaining exposure is due to man-made forms such as those used in medical imaging techniques.

Exposure to man-made forms of ionizing radiations is generally much higher in developed countries where the use of nuclear imaging techniques is much more common than in developing countries.

### b. Non-ionizing radiations

**Non-ionizing radiation** refers to any type of electromagnetic radiation that does not carry enough energy to ionize atoms or molecules. Examples of non-ionizing radiations include visible light, microwaves, ultraviolet (UV) radiation, infrared radiation, radio waves, radar waves, mobile phone signals and wireless internet connections. Although UV has been classified as a non-ionizing radiation but it has been proven that high levels of UV-radiation can cause sunburn and increase the risk of skin cancer developing.

Scientific investigations suggest that the use of telecommunications devices such as mobile **phones** may be damaging, but no risk associated with the use of these devices has yet been identified in any scientific studies. This energy is emitted both inside the body and externally, through both natural and man-made processes.

#### 12.1.2 Radiation penetration in body tissue

### ACTIVITY 12.2

The figure below shows the penetrating power of radiation represented by A, B and C. Use the figure to answer the following questions.

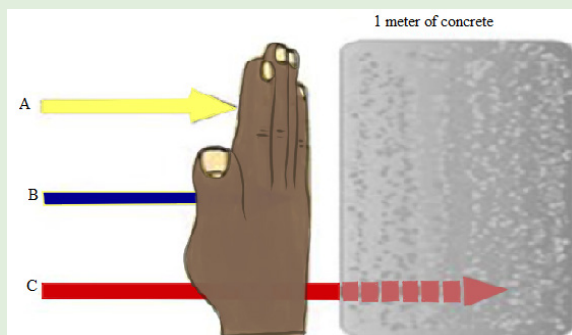

Fig.12. 3 The penetrating power of radiation

#### Questions:

- Interpret the figure and write the names of letters A, B and C labeled on the figure above?
- Which of the three types of radiation has high penetrating power? Explain to support your idea.
- Outline four uses of the man-made sources of radiation?
- How does radiation affect me? Explain clearly with scientific reasoning.

An important characteristic of the various ionising radiations is how deeply they can penetrate the body tissues. X-rays, gamma rays, and neutrons of sufficient energy described below can reach all tissues of the body from an external source.

### Alpha Radiation

**Alpha radiation** occurs when an atom undergoes radioactive decay, giving off an  $\alpha$ -particle consisting of two protons and two neutrons (essentially the nucleus of a helium-4 atom) following the equation

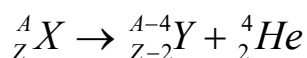

Due to their charge and mass, alpha particles interact **strongly** with matter, and can only travel a few centimeters in air. A thin sheet of paper, on the other hand, stops alpha particles. They are also stopped by the superficial dead layer of skin that is only 70  $\mu\text{m}$  thick. Therefore, radionuclides that emit only alpha particles are harmless unless you take them into the body. This you might do by inhalation (breathing in) or ingestion (eating and drinking).

### Beta Radiation

Beta radiation takes the form of either an electron or a positron (a particle with the size and mass of an electron, but with a positive charge) being emitted from an atom. Due to their smaller mass, they are able to travel further in air, up to a few meters, and can be stopped by a thick piece of plastic, or even a stack of paper. Such radiation can penetrate the skin a few centimeters, posing somewhat of an external health risk. The depth to which beta particles can penetrate the body depends on their energy.

High-energy beta particles (several MeV) may penetrate a cm of a tissue, although most are absorbed in the first few mm. As a result, beta emitters outside the body are hazardous only to surface tissues such as the skin or the lenses of the eye. When you take beta emitters into the body, they will irradiate internal tissues and then become a much more serious hazard.

### Gamma Radiation

Gamma radiation, unlike alpha or beta, does not consist of any particles, instead consisting of a photon of energy being emitted from an unstable nucleus. Having no mass or charge, gamma radiation can travel much farther through air than alpha or beta, losing (on average) half its energy. Gamma waves can be stopped by a thick or dense enough layer material, with high atomic number. Materials such as lead can be used as the most effective form of shielding.

## X-Rays

X-rays are similar to gamma radiation, with the primary difference being that they originate from the electron cloud. This is generally caused by energy changes in an electron, such as moving from a higher energy level to a lower one, causing the excess energy to be released. X-Rays are longer-wavelength and (usually) lower energy than gamma radiation, as well.

## Neutron Radiation

Neutron radiation consists of a free neutron, usually emitted as a result of spontaneous or induced nuclear fission. They are able to travel hundreds or even thousands of meters in air; they are however able to be effectively stopped if blocked by a hydrogen material, such as concrete or water.

Neutron radiation occurs when neutrons are ejected from the nucleus by nuclear fission and other processes. The nuclear chain reaction is an example of nuclear fission, where a neutron being ejected from one fission atom will cause another atom to fission, ejecting more neutrons. Unlike other radiations, neutron radiation is absorbed by materials with lots of hydrogen atoms, like paraffin wax and plastics.

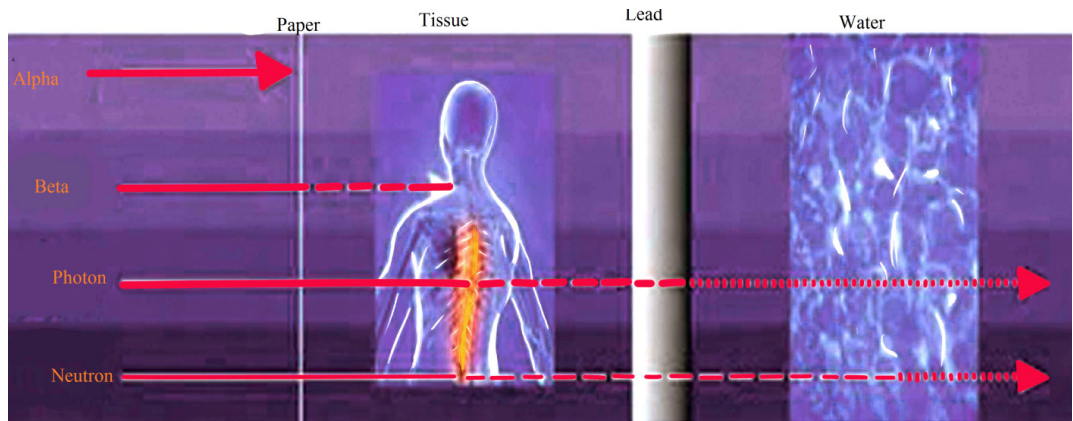

Fig.12. 4: Types of ionizing radiation

### 12.1.3 Radiation dosimetry

#### ACTIVITY 12.3:

- What does the term **Dosimeter in radiation dosimetry** mean?
- Who Should Wear a Dosimeter? Suggest reasons why it is very important to wear a dosimeter?**

Just as for drugs, the effect of radiation depends on the amount a person has received. Therefore, amounts of radiation received are referred to as **doses**, and the measurement of such doses is known as **dosimetry**.

**Dosimeters** are used to monitor your occupational dose from radioactive material or radiation-producing equipments. Most individuals working with X-ray producing equipment in the hospital will be issued with a **dosimeter**. For those individuals working in the research laboratory setting, **dosimeters** will be issued based on the nuclide and total activity that will be used. Dosimeters are integrating detectors; that is, they accumulate the radiation dose and give off an amount of light which is proportional to that dose.

The energy absorption properties of dosimeters are designed to be very similar to tissue, so they are very effective as personnel dosimeters. These devices are used to measure exposures from **x-ray, gamma ray and high energy beta particles**. Dosimeters are not suitable for measuring exposures to low energy beta particles or alpha particles.

### 12.1.4 Radiation exposure

#### ACTIVITY 12.4:

- What are the symptoms of radiation exposure?
- Explain briefly the effects of radiation exposure to the human body?
- It is possible that side effects can happen when a person undergoes radiation treatment for cancer. Suggest the common side effects of radiation exposure to the human body?
- Does radiation exposure to the human body induce risks? Support your decision with clear explanations.

Long-term exposure to small amounts of radiation can lead to **gene mutations** and increase the **risk of cancer**, while exposure to a large amount over a brief period can lead to **radiation sickness**.

**Exposure** is a measure of the ionization produced in air by X-rays or  $\gamma$  rays, and it is defined in the following manner. A beam of X-rays or  $\gamma$  rays is sent through a mass  $m$  of dry air at standard temperature and pressure (stp:  $0^\circ\text{C}$ , 1 atm). In passing through the air, the beam produces positive ions whose total charge is  $q$ . Exposure is defined the total charge per unit mass of air. The SI unit for exposure is coulomb per unit mass ( $\text{C}/\text{kg}$ ).

The commonly used unit for exposure  $E$  is the roentgen(R). 1R is the amount of electromagnetic radiation which produces in one gram of air  $2.58 \times 10^{-7} \text{C}$  at normal temperature ( $22^\circ\text{C}$ ) and pressure ( $760 \text{ mmHg}$ ) conditions.

$$1R = 2.58 \times 10^{-4} \text{ C} / \text{kg}$$

Since the concept of exposure is defined in terms of the ionizing abilities of X-rays and  $\gamma$  rays in air, it does not specify the effect of radiation on living tissue. For biological purposes, the absorbed dose is more suitable quantity, because it is the energy absorbed from the radiation per unit mass of absorbing material.

### 12.1.5 Absorbed radiation dose

#### ACTIVITY 12.5

- a. What does the term absorbed dose mean in medical treatment?
- b. In the application of radiation in medicine, we use the statement “A measure of the risk of biological harm”. Brainstorm and explain clearly what the statement means.
- c. Explain why doses of alpha and gamma radiation produce unequal biological effects?

What is important when we analyze the effect of radiation on human being is not so much the total dose to the whole system but the dose per kg. That’s why a doctor will prescribe smaller doses of medicine for children than for adults. A similar approach is used in radiation protection measurements, where the unit of absorbed dose is specified in terms of the amount of energy deposited by radiation in 1 kg of material. This unit is the Gray, abbreviated Gy.

It was named in honor of Louis Gray, who was a very big name in the early days of radiation dosimetry. An absorbed radiation dose of 1 Gray corresponds to the deposition of 1 joule of energy in 1 kg of material. The gray is a measure of energy absorbed by 1 kg of any material, be it air, water, tissue or whatever. A person who has absorbed a whole body dose of 1 Gy has absorbed one joule of energy in each kg of its body tissue.

As we shall see later, the gray is a fairly hefty dose, so for normal practical purposes we use the milligray (abbreviated mGy) and the microgray (abbreviated  $\mu$ Gy).

The gray is a physical unit. It describes the physical effect of the incident radiation (i.e., the amount of energy deposited per kg), but it tells us nothing about the biological consequences of such energy deposition in tissue. Studies have shown that alpha and neutron radiation cause greater biological damage for a given energy deposition per kg of tissue than gamma radiation does.

In other words, equal doses of, say, alpha and gamma radiation produce unequal biological effects. This is because the body can more easily repair damage from radiation that is spread over a large area than that which is concentrated in a small area. Because more **biological damage** is caused for the same physical dose.

### 12.1.6 Quality factors

Quality factors are used to compare the biological effects from different types of radiation. For example, fast neutron radiation is considered to be 20 times as damaging as X-rays or gamma radiation. You can also think of fast neutron radiation as being of “higher quality”, since you need less absorbed dose to produce equivalent biological effects. This quality is expressed in terms of the Quality Factor (Q). The quality factor of a radiation type is defined as the ratio of the biological damage produced by the absorption of 1 Gy of that radiation to the biological damage produced by 1 Gy of X or gamma radiation.

The Q of a certain type of radiation is related to the density of the ion tracks it leaves behind it in tissue; the closer together the ion pairs, the higher the Q.

### 12.1.7 Equivalent dose

The absorbed radiation dose, when multiplied by the Q of the radiation delivering the dose, will give us a measure of the biological effect of the dose. This is known as the equivalent dose. The unit of equivalent dose H is the Sievert (Sv). An equivalent dose of one Sievert represents that quantity of radiation dose that is equivalent, in terms of specified biological damage, to one gray of X or gamma rays.

In practice, we use the millisievert (mSv) and microsievert ( $\mu$ Sv). The sievert is the unit that we use all the time, because it is the only one that is meaningful in terms of biological harm. In calculating the equivalent dose from several types of radiation (we call this “mixed radiation”), all measurements are converted to Sv, mSv or  $\mu$ Sv and added. Most of the radiation instruments we use to measure doses or dose rates read in mSv or  $\mu$ Sv. Few other instruments can read in mGy or  $\mu$ Gy, but they measure only gamma radiation.

The table 13.1 lists some typical relative biological effectiveness ( $R_{BE}$ ) values for different kinds of radiation, assuming that an average biological tissue is being irradiated. The values of  $R_{BE} = 1$  indicate that  $\gamma$  rays and  $\beta^-$  particles produce the same biological damage as do 200 keV X-rays. The large  $R_{BE}$  values indicate that protons,  $\alpha$  -particles, and fast neutrons cause substantially more damage.

Types of radiation	$R_{BE}$	Types of radiation	$R_{BE}$
200 keV X-rays	1	$\beta^-$ particles	1
$\gamma$ rays	1	$\alpha$ particles	10-20
Protons	10	Neutrons	
Slow	2	Fast	10

Table 12. 1: Relative biological effectiveness for various types of radiation

### 12.1.8 Radiation protection

The effects of radiation at **high** doses and dose rates are reasonably well documented. A very large dose delivered to the whole body over a short time will result in the death of the exposed person within days.

We know from these that some of the health effects of exposure to radiation do not appear unless a certain quite large dose is absorbed. However, many other effects, especially cancers are readily detectable and occur more often in those with moderate doses. At lower doses and dose rates, there is a degree of recovery in cells and in tissues. Radiation protection sets examples for other safety disciplines in two unique respects:

- First, there is the assumption that any increased level of radiation above natural background will carry some risk of harm to health.
- Second, it aims to protect future generations from activities conducted today.

The use of radiation and nuclear techniques in medicine, industry, agriculture, energy and other scientific and technological fields has brought tremendous benefits to society. The benefits in medicine for diagnosis and treatment in terms of human lives saved are large in size. No human activity or practice is totally devoid of associated risks. Radiation should be viewed from the perspective that the benefit from it to mankind is less harmful than from many other agents.

#### Quick check 12.2:

At what level is radiation harmful? Explain your idea

**Note:** The optimization of patients' protection is based on a principle that the dose to the irradiated target (tumor) must be as high as it is necessary for effective treatment while protecting the healthy tissues to the maximum extent possible.

### 12.1.9 Checking my progress

1. Does receiving external-beam radiation make a person radioactive or able to expose others to radiation? Explain to support idea
2. How can I be sure that the external-beam radiating machine isn't damaging normal, healthy tissue in my body? Explain clearly with scientific reasoning.
3. I am having an imaging test using radioactive materials. Will I be radioactive after the test? Comment to support your decision.
4. All my radioactive material is secured properly and I have empty waste containers in the lab. Do I have to lock the room? Explain clearly to justify your decision.

## 12.2 BIOLOGICAL EFFECTS OF RADIATION EXPOSURE

### 12.2.1 Deterministic and stochastic effects

#### ACTIVITY 12.6

Is the use of ionizing radiation in medicine beneficial to human health? Explain to support your point.

1. Are there risks to the use of ionizing radiation in medicine? Explain your answer.
2. How do we quantify the amount of radiation?
3. What do we know about the nature (mechanism) of radiation-induced biological effects?
4. How are effects of radiation classified?

Effects of radiations due to cell killing have a practical threshold dose below which the effect is not evident but in general when the effect is present its severity increases with the radiation dose.

The threshold doses are not an absolute number and vary somewhat by individual. Effects due to **mutations** (such as cancer) have a probability of occurrence that increases with dose.

#### a. Deterministic effects:

These effects are observed after large absorbed doses of radiation and are mainly a consequence of radiation induced cellular death. They occur only if a large proportion of cells in an irradiated tissue have been killed by radiation, and the loss can be compensated by increasing cellular proliferation.

#### b. Stochastic effects:

They are associated with long term, low level (**chronic**) exposure to radiation. They have no apparent threshold. The risk from exposure increases with increasing dose, but the severity of the effect is independent of the dose.

Irradiated and surviving cells may become modified by induced mutations (somatic, hereditary). These modifications may lead to two clinically significant effects: malignant neoplasm (cancer) and hereditary mutations.

The frequency or intensity of biological effects is dependent upon the total energy of radiation absorbed (in joules) per unit mass (in kg) of a sensitive tissues or organs. This quantity is called **absorbed dose** and is expressed in gray (Gy).

In evaluating biological effects of radiation after partial exposure of the body further factors such as the varying sensitivity of different tissues and absorbed doses to different organs have to be taken into consideration.

To compare risks of partial and whole body irradiation at doses experienced in diagnostic radiology and nuclear medicine a quantity called equivalent or effective dose is used. A cancer caused by a small amount of radiation can be just as malignant as one caused by a high dose.

### ACTIVITY 12.7

1. What is magnitude of the risk for cancer and hereditary effects?
2. Is ionizing radiation from medical sources the only one to which people is exposed?
3. What are typical doses from medical diagnostic procedures?
4. Can radiation doses in diagnosis be managed without affecting the diagnostic benefit? Explain to support your decision.
5. Are there situations when diagnostic radiological investigations should be avoided? Explain to support your decision.

The lifetime value for the average person is roughly a 5% increase in fatal cancer after a whole body dose of 1 Sv. It appears that the risk in fetal life, in children and adolescents exceeds somewhat this average level (by a factor of 2 or 3) and in persons above the age of 60 it should be lower roughly by a factor of ~ 5.

Animal models and knowledge of human genetics, the risk of hereditary deleterious effects have been estimated to not be greater than 10% of the radiation induced carcinogenic risk.

All living organisms on this planet, including humans, are exposed to radiation from natural sources. An average yearly effective dose from natural background amounts to about 2.5 mSv. This exposure varies substantially geographically (from 1.5 to several tens of mSv in limited geographical areas).

Various diagnostic radiology and nuclear medicine procedures cover a wide dose range based upon the procedure. Doses can be expressed either as absorbed dose to a single tissue or as effective dose to the entire body which facilitates comparison of doses to other radiation sources (such as natural background radiation).

There are several ways to reduce the risks to very, very low levels while obtaining very beneficial health effects of radiological procedures.

Quality assurance and quality control in diagnostic radiology and nuclear medicine play also a fundamental role in the provision of appropriate, sound radiological protection of the patient.

There are several ways that will minimize the risk without sacrificing the valuable information that can be obtained for patients' benefit. Among the possible measures it is necessary to justify the examination before referring a patient to the radiologist or nuclear medicine physician.

Failure to provide adequate clinical information at referral may result in a wrong procedure or technique being chosen by radiologist or nuclear medicine specialist.

An investigation may be seen as a useful one if its outcome - positive or negative influences management of the patient. Another factor, which potentially adds to usefulness of the investigation, is strengthening confidence in the diagnosis. Irradiation for legal reasons and for purposes of insurance should be carefully limited or excluded.

### ACTIVITY 12.8

1. Are there special diagnostic procedures that should have special justification? Explain to support your decision.
2. Do children and pregnant women require special consideration in diagnostic procedures?
3. What can be done to reduce radiation risk during the performance of a diagnostic procedure?

While all medical uses of radiation should be justified, it stands to reason that the higher the dose and risk of a procedure, the more the medical practitioner should consider whether there is a greater benefit to be obtained.

Among these special position is occupied by computed tomography (CT), and particularly its most advanced variants like spiral or multi slice CT.

Both the fetus and children are thought to be more radiosensitive than adults. Diagnostic radiology and diagnostic nuclear medicine procedures (even in combination) are extremely unlikely to result in doses that cause malformations or a decrease in intellectual function. The main issue following in childhood exposure at typical diagnostic levels (<50 mGy) is cancer induction.

Medically indicated diagnostic studies remote from the fetus (e.g. radiographs of the chest or extremities, ventilation/perfusion lung scan) can be safely done

at any time of pregnancy if the equipment is in proper working order. Commonly the risk of not making the diagnosis is greater than the radiation risk.

If an examination is typically at the high end of the diagnostic dose range and the fetus is in or near the radiation beam or source, care should be taken to minimize the dose to the fetus while still making the diagnosis. This can be done by tailoring the examination and examining each radiograph as it is taken until the diagnosis is achieved and then terminating the procedure

For children, dose reduction is achieved by using technical factors specific for children and not using routine adult factors. In diagnostic radiology care should be taken to minimize the radiation beam to only the area of interest. Because children are small, in nuclear medicine the use of administered activity lower than that used for an adult will still result in acceptable images and reduced dose to the child. The most powerful tool for minimizing the risk is appropriate performance of the test and optimization of radiological protection of the patient. These are the responsibility of the radiologist or nuclear medicine physician and medical physicist.

The basic principle of patients' protection *in radiological X-ray investigations and nuclear medicine diagnostics* is that necessary diagnostic information of clinically satisfactory quality should be obtained at the expense of a dose as low as reasonably achievable, taking into account social and financial factors.

### 12.2.2 Effects of radiation exposure

Quick check 13.1:

Will small radiation doses hurt me?

Some effects may occur immediately (days or months) while others might take tens of years or even get passed to the next generation. Effects of interest for the person being exposed to radiation are called **somatic effects** and effects of interest that affect our children are called genetic effects.

#### I. Radiation Health Effects

Ionizing radiation has sufficient energy to cause chemical changes in cells and damage them. Some cells may die or become abnormal, either temporarily or permanently. By damaging the genetic material (DNA) contained in the body's cells, radiation can cause cancer.

Fortunately, our bodies are extremely efficient at repairing cell damage. The extent of the damage to the cells depends upon the amount and duration of the exposure, as well as the organs exposed.

Exposure to an amount of radiation all at once or from multiple exposures in a short period of time. In most cases, a large acute exposure to radiation causes both immediate ( radiation sickness) and delayed effects (cancer or death), can cause sickness or even death within hours or days. Such acute exposures are extremely rare.

## II. Chronic Exposure

With chronic exposure, there is a delay between the exposure and the observed health effect. These effects can include cancer and other health outcomes such as benign tumors, cataracts, and potentially harmful genetic changes.

Some radiation effects may occur immediately (days or months) while others might take years or even get passed to the next generation. Effects of interest for the person being exposed to radiation are called **somatic effects** and effects of interest that affect our children are called **genetic effects**.

### ACTIVITY 12.9: Low levels of radiation exposure

What is the safe level of radiation exposure? Explain your answer.

What is the annual radiation exposure limit? Explain your answer

Radiation risks refer to all excess cancers caused by radiation exposure (incidence risk) or only excess fatal cancers (mortality risk). Risk may be expressed as a percent, a fraction, or a decimal value.

**For example**, a 1% excess risk of cancer incidence is the same as a 1 in a hundred (1/100) risk or a risk of 0.01. However, it is very hard to tell whether a particular cancer was caused by **very low doses** of radiation or by something else. While experts disagree over the exact definition and effects of “**low dose**”. Radiation protection standards are based on the premise that any radiation dose carries some risk, and that risk increases directly with dose.

#### Note:

- The risk of cancer from radiation also depends on age, sex, and factors such as tobacco use.
- Doubling the dose doubles the risk.

Acute health effects occur when large parts of the body are exposed to a large amount of radiation. The large exposure can occur all at once or from multiple exposures in a short period of time. Instances of acute effects from environmental sources are very rare.

### 12.2.3 Safety precautions for handling radiations

#### ACTIVITY 12.10: Safety precautions to be recognized when handling radiation

- Who is involved in planning my radiation treatment?
- How is the treatment plan checked to make sure it is best for me?
- What procedures do I have in place so that the treatment team is able to treat me safely?
- How can I be assured that my treatment is being done correctly every day?
- What is the difference between a medical error and a side effect?
- Outline the measures taken to reduce doses from external exposure

Shortening the time of exposure, increasing distance from a radiation source and shielding are the basic countermeasures (or protective measures) to reduce doses from external exposure.

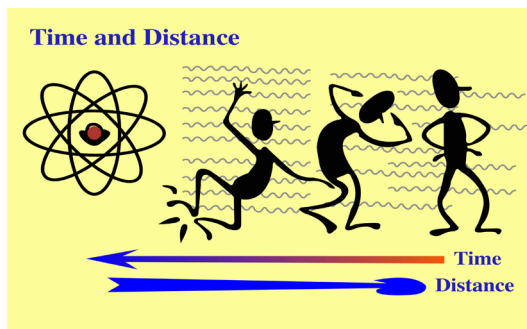

Fig.12. 5 Illustration of distance and time from source of radiation

**Note:** Time: The less time that people are exposed to a radiation source, the less the absorbed dose  
Distance: The farther away that people are from a radiation source, the less the absorbed dose.

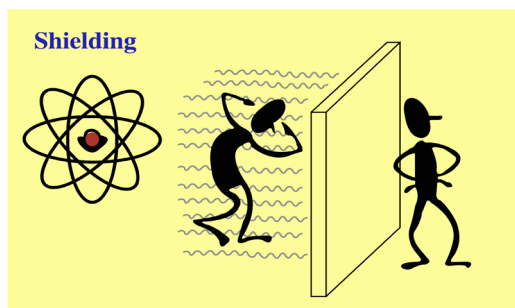

Fig.12. 6 Illustration of shielding

**Note:** Shielding: Barriers of lead, concrete or water can stop radiation or reduce radiation intensity.

There are four main factors that contribute to how much radiation a person absorbs from a source. The following factors can be controlled to minimize **exposure to radiation:**

### **I. The distance from the source of radiation**

The intensity of radiation falls sharply with greater distance, as per the inverse square law. Increasing the distance of an individual from the source of radiation can therefore reduce the dose of radiation they are exposed to.

For example, such distance increases can be achieved simply by using forceps to make contact with a radioactive source, rather than the fingers.

### **II. Duration of exposure**

The time spent exposed to radiation should be limited as much as possible. The longer an individual is subjected to radiation, the larger the dose from the source will be.

One example of how the time exposed to radiation and therefore radiation dose may be reduced is through improving training so that any operators who need to handle a radioactive source only do so for the minimum possible time.

### **III. Reducing incorporation into the human body**

Potassium iodide can be given orally immediately after exposure to radiation. This helps protect the thyroid from the effects of ingesting radioactive iodine if an accident occurs at a nuclear power plant. Taking Potassium iodide in such an event can reduce the risk of thyroid cancer developing.

### **IV. Shielding**

**Shielding** refers to the use of absorbent material to cover the source of radiation, so that less radiation is emitted in the environment where humans may be exposed to it. These biological shields vary in effectiveness, depending on the material's cross-section for scattering and absorption.

The thickness (shielding strength) of the material is measured in  $\text{g/cm}^2$ . Any amount of radiation that does penetrate the material falls exponentially with increasing thickness of the shield.

Some examples of the steps taken to minimize the effects of radiation exposure are described below;

- The exposed individual is removed from the source of radiation.
- If radiation exposure has led to destruction of the bone marrow, the number of healthy white blood cells produced in the bone marrow will be depleted.
- If only part of the body has been exposed to radiation rather than the whole body, treatment may be easier because humans can withstand radiation exposure in large amounts to non-vital body parts.

In every medicine there is a little poison. If we use radiation safely, there are benefits and if we use radiation carelessly and high doses result, there are consequences.

Ionizing radiation can change the structure of the cells, sometimes creating potentially harmful effects that are more likely to cause changes in tissue. These changes can interfere with cellular processes so cells might not be able to divide or they might divide too much.

Radioactive rays are penetrating and emit **ionizing radiation** in the form of electromagnetic waves or energetic particles and can therefore **destroy living cells**. Small doses of radiation over an extended period may cause cancer and eventually death. Strong doses can kill instantly. Marie Curie and Enrico Fermi died due to **exposure to radiation**.

Several precautions should be observed while handling radioisotopes. Some of these are listed in the following:

- No radioactive substance should be handled with bare hands. Alpha and beta emitters can be handled using thick gloves. Gamma ray emitters must be handled only by remote control that is by mechanical means. Gamma rays are the most dangerous and over exposure can lead to serious biological damage.
- Radioactive materials must be stored in thick lead containers.
- Reactor and laboratories dealing with and conducting experiments with radioactive metals must be surrounded with thick concrete lined with lead.
- People working with radioactive isotopes must wear protective clothing which is left in the laboratory. The workers must be checked regularly with dosimeters, and appropriate measures should be taken in cases of overdose.
- Radioactive waste must be sealed and buried deep in the ground.

### 12.2.3 Checking my progress

1.
  - a. What does the term background radiation mean?
  - b. What is radiation – am I exposed to background radiation each day even if I do not have an X-ray examination?
2. What are the risks associated with radiation from diagnostic X-ray imaging and nuclear medicine procedures?
3. How do I decide whether the risks are outweighed by the benefits of exposure to X-radiation when I have a radiology test or procedure?
4. Are there alternatives to procedures that involve ionizing radiation that would answer my doctor's question? Justify your answer with clear facts.
5. What kinds of safety checks do you perform each day?
6. How often does the medical physicist check the various machines involved during my treatment are working properly?
7. If I have side effects after my treatment, who can I call?
  - a. My best friend
  - b. My primary care doctor
8. I have a question about a radiation treatment I had many years ago. Who should I call?

## 12.3 CONCEPT OF BALANCED RISK.

### 12.3.1 Risks of ionizing radiation in medical treatment

#### ACTIVITY 12.11: balanced risk

Brainstorm and write briefly how balance risks in medical treatment occur?

Risk in the area of radiation medicine has several dimensions that are less common in other areas of medicine. First, there may be risks from overexposure that do not cause immediate injury. For example, the causal connection, if any, may be difficult or impossible to verify for a malignancy that surfaces several years after an inappropriate exposure. Second, the risks associated with the medical use of ionizing radiation extend beyond the patient and can affect health care workers and the public.

In amplifying these and other aspects of the risks that attend medical uses of ionizing radiation, the discussion addresses the following issues: human error

and unintended events; rates of misadministration in radiation medicine; inappropriate and unnecessary care; and efforts that reduce misadministration and inappropriate care.

### ***12.3.2 Human Error and Unintended Events***

Errors occur throughout health care: A pharmacist fills a prescription with the wrong medicine; an x-ray technician takes a film of the wrong leg; a surgeon replaces the wrong hip. The advent of complex medical technology has increased the opportunity for error even as it has increased the opportunity for effecting cures.

By educating health care workers, and by circumscribing their actions, human error may be minimized. However, some number of mistakes will always, unavoidably, be made, and no amount of training or double-checking can erase that fact.

### ***12.3.3 Comparison of risks in the use of ionizing radiation***

The comparison of relative risks of misadministration in by-product radiation medicine to error rates and events in other medical practice settings, as well as the comparison of disease and death rates with the risks of the therapeutic administration itself, help to some extent to place ionizing radiation use in a broader context.

To achieve this success requires the highest standards of performance (accuracy of delivered dose), both when planning irradiation for an individual patient and in actual delivery of the dose.

In a large number of cases, decreasing the dose to the target volume is not possible since it would unacceptably decrease the cure rate. In these cases present technological developments aim at optimizing the patients' protection, keeping the absorbed tumor dose as high as is necessary for effective treatment while protecting nearby healthy tissues.

It should be remembered that successful eradication of a malignant tumor by radiation therapy requires high-absorbed doses and there is a delayed (and usually low) risk of late complication. The above mentioned techniques are used to provide the best benefit/risk ratio.

A malignant tumor in a pregnant woman may require radiotherapy in attempt to save life of the patient. If a tumor is located in a distant part of the body, the therapy with individually tailored protection of the abdomen (screening) - may proceed.

When thyroid cancer with metastases is diagnosed in a pregnant woman, treatment with <sup>131</sup>I is not compatible with continuation of the pregnancy. The treatment should then be delayed until delivery if doing so wouldn't put the mother's life in danger.

Medical radiation can be delivered to the patient from a radiation source outside the patient. Regardless of how much dose the patient received, they do not become radioactive or emit radiation.

- Balancing risks are often summarized in the following:
- The demand for imaging, especially computed tomography, that has increased vastly over the past 20 years
- An estimated 30% of computed tomography tests that may be unnecessary
- Ionizing radiation that may be associated with cancer.
- The risks of radiation exposure that is often overlooked and patients are seldom made aware of these risks
- The requesting doctor who must balance the risks and benefits of any high radiation dose imaging test, adhering to guideline recommendations if possible
- Difficult cases that should be discussed with a radiologist, ideally at a clinic radiological or multidisciplinary team meeting.

### **12.3.4 Checking progress**

1. When patients are intentionally exposed to ionizing radiation for medical purposes, do they suffer unintentional exposures as a result of error or accident? Comment to support your idea.
2. What can be done to reduce radiation risk during conduct of radiation therapy?
3. Can pregnant women receive radiotherapy? Explain to support your decision.
4. Can patients' treatment with radiation affect other people? Explain to support your decision.

## **12.4 THE HALF-LIVES: PHYSICAL, BIOLOGICAL, AND EFFECTIVE**

### **ACTIVITY 12.12**

Distinguish between physical half-life, biological half-life and effective half-life.

Brainstorm and write the distinction between physical half-life, biological half-life and effective half-life in your note books.

The half-life is a characteristic property of each radioactive species and is independent of its amount or condition. The effective half-life of a given isotope is the time in which the quantity in the body will decrease to half as a result of both radioactive decay and biological elimination.

There are three half-lives that are important when considering the use of radioactive drugs for both diagnostic and therapeutic purposes. While both the physical and **biological** half-lives are important since they relate directly to the disappearance of radioactivity from the body by two separate pathways (radioactive decay, biological clearance), there is no half-life as important in humans as the **effective half-life**.

The half-life takes into account not only elimination from the body but also radioactive decay. If there is ever a question about residual activity in the body, the calculation uses the effective half-life; in **radiation dosimetry** calculations, the only **half-life** that is included in the equation is the effective half-life.

### **12.4.1 Physical half Lives**

**Physical half-life** is defined as the period of time required to reduce the radioactivity level of a source to exactly one half its original value due solely to radioactive decay. The physical half-life is designated  $T_p$  or more commonly  $T_{\frac{1}{2}}$

By default, the term  $T_{12}$  refers to the physical half-life and  $T_p$  is used when either or both of the other two half-lives are included in the discussion.

$$T_{\frac{1}{2}} = \frac{\ln 2}{\lambda} \text{ Where } \lambda \text{ is the radioactive constant of the radio substance}$$

There are a few things to note about the  $T_p$  :

- The  $T_p$  can be measured directly by counting a sample at 2 different points in time and then calculating what the half-life is.
- For example, if activity decreases from 100% to 25% in 24 hours, then the half-life is 12 hours since a decrease from 100% to 50% to 25% implies that 2 half-lives have elapsed.

The **physical half-life** is unaffected by anything that humans can do to the isotope. High or low pressure or high or low temperature has no effect on the decay rate of a radioisotope.

### 12.4.2 Biological half lives

**Biological Half-life** is defined as the period of time required to reduce the amount of a drug in an organ or the body to exactly one half its original value due solely to biological elimination. It is typically designated  $T_b$ . There are a few things to note about the  $T_b$  :

- For radioactive compounds, we have to calculate the  $T_b$  because the mass of the isotope is usually on the nanogram scale and, when distributed throughout the body, and especially in the target organ, concentrations are in the pictogram/ml range, much too small to measure directly.
- For non-radioactive compounds, we can measure the  $T_b$  directly. For example, assuming that a person is not allergic to penicillin, we could give 1 000 mg of the drug and then measure the amount present in the blood pool and in the urine since we administered such a large amount of the drug.
- $T_b$  is affected by many external factors. Perhaps the two most important are hepatic and renal function. If kidneys are not working well, we would expect to see a high background activity on our scans.
- Each individual organ in the body has its own  $T_b$  and the whole body also has a  $T_b$  representing the weighted average of the  $T_b$  of all internal organs and the blood pool. It is therefore very important to have a frame of reference. For example, do you need to know the  $T_b$  of the drug in the liver or in the whole body?
- All drugs have a  $T_b$  , not just radioactive ones. Drug package inserts often refer to the half-time of clearance of a drug from the blood pool or through the kidneys.
- Since the whole body has a  $T_b$  representing the weighted average of the  $T_b$  of all internal organs, it will almost never equal that of an internal organ.

### 12.4.3 Effective half lives

**Effective half-life** is defined as the period of time required to reduce the radioactivity level of an internal organ or of the whole body to exactly one half its original value due to both elimination and decay.

It is designated  $T_e$  can be measured directly. For example, one can hold a

detection device 1 m from the patient's chest and count the patient multiple times until the reading decreases to half of the initial reading.

The patient is permitted to use the rest room between readings as needed, so both elimination and decay are taking place. The half-life being measured in this case is the  $T_e$  and  $T_e$  is affected by the same external factors that affect  $T_b$  since  $T_e$  is dependent upon  $T_b$ .

$$T_e = \frac{T_p \cdot T_b}{T_p + T_b}$$

Where

$T_p$ : physical half-life

$T_b$ : biological half-life

### EXAMPLE 12.1

For a Xe-133 for pulmonary ventilation study, where  $T_p = 5.3$  days and  $T_b = 15$  s, calculate the effective half-life of Xe.

#### Answer

We convert first  $T_p$  in seconds i.e.  $T_p = 457920$  s

$$T_e = \frac{T_p \cdot T_b}{T_p + T_b} = \frac{457920 \times 15}{457920 + 15} = 15 \text{ s}$$

#### 12.4.4 Checking my progress

1. I-131 sodium iodide has a  $T_b$  of 24 days. What is  $T_e$  if  $T_p = 8$  d?
2. A Tc-99 m compound has a  $T_e = 1$  days. What is  $T_b$  if  $T_p = 6$  d?
3. A radiopharmaceutical has a biological half-life of 4.00 hr and an effective half-life of 3.075 hr. What isotope was used?

## END UNIT ASSESSMENT 12

### A. Multiple choices.

- Which of the following would reduce the cell damage due to radiation for a lab technician who works with radioactive isotopes in a hospital or lab?
  - Increase the worker's distance from the radiation source.
  - Decrease the time the worker is exposed to the radiation.
  - Use shielding to reduce the amount of radiation that strikes the worker.
  - Have the worker wear a radiation badge when working with the radioactive isotopes.
  - All of the above.
- If the same dose of each type of radiation was provided over the same amount of time, which type would be most harmful?
  - X-rays.
  - $\alpha$  Rays.
  - $\gamma$  rays.
  - $\beta$  particles.
- Which of the following is true?
  - Any amount of radiation is harmful to living tissue.
  - Radiation is a natural part of the environment.
  - All forms of radiation will penetrate deep into living tissue.
  - None of the above is true.
- Which radiation induces the most biological damage for a given amount of energy deposited in tissue?
  - Alpha particules.
  - Gamma radiation.
  - C. Beta radiation.
  - D. All do the same damage for the same deposited energy.
- Which would produce the most energy in a single reaction?
  - The fission reaction associated with uranium-235.
  - The fusion reaction of the Sun (two hydrogen nuclei fused to one helium nucleus).
  - Both (A) and (B) are about the same.
  - Need more information.

6. The fuel necessary for fusion-produced energy could be derived from
- a. Water.
  - b. Uranium.
  - c. Sunlight.
  - d. Superconductors.
  - e. Helium.

### B. Structured questions

7. If the equipment isn't working and my treatment is delayed or postponed, who checks that it is safe to use again? And will this delay affect my cancer?
8. Do you have weekly chart rounds where you review patient-related information in peer review?
9. Will you take imaging scans regularly during my treatment to verify position of my treatment? Who reviews those scans?
10. People who work around metals that emit alpha particles are trained that there is little danger from proximity or touching the material, but they must take extreme precautions against ingesting it. Why? (Eating and drinking while working are forbidden.)
11. What is the difference between absorbed dose and effective dose? What are the SI units for each?
12. Radiation is sometimes used to sterilize medical supplies and even food. Explain how it works.
13. How might radioactive tracers be used to find a leak in a pipe?
14. Explain that there are situations in which we may or may not have control over our exposure to ionizing radiation.
- a. When do we not have control over our exposure to radiation?
  - b. When do we have control over our exposure to radiation?
  - c. Why might we want to limit our exposure to radiation when possible?
15. Does exposure to heavy ions at the level that would occur during deep-space missions of long duration pose a risk to the integrity and function of the central nervous system?
16. Radiation protection of ionizing radiation from radiation sources is particularly difficult. Give a reason for this difficulty.

### C. Essay questions

17. I always lock my radioactive material-use rooms. However, renovators came in during the weekend, worked, and left the door open while they were on their lunch break. Am I responsible and how can I prevent this from happening? Debate on the situation above to support your answer.
18. How can I ensure that personnel who work in my lab, but do not use radioactive material, do not violate the security requirements? Debate to support your idea.
19. A Housekeeping staff member opens my radioactive material-use room after working hours and does not lock it when they leave. What should I do? Explain clearly to support your idea.
20. Make a research and predict what steps that can or might be taken to reduce the exposure to radiation (consider if living near a radioactive area like an abandoned uranium mine, if finding a radioactive source, or in the event of a nuclear explosion or accident).

# BIBLIOGRAPHY

- eschooltoday*. (2008-2018). Retrieved February 19, 2018, from natural disasters: <http://eschooltoday.com>.
- eschooltoday*. (2008-2018). Retrieved February 19, 2018, from Climate change: <http://www.threastafrican.co.ke>.
- (2017). Retrieved from [rwanda/Business/kigali](http://www.threastafrican.co.ke).
- Abbot, A. F., & Cockcroft, J. (1989). *Physics* (5 ed.). Heinemann: Educational Publishers.
- Atkins, K. R. (1972). *Physics-Once over Lightly*. New York : New York.
- Avison, J. (1989). *The world of PHYSICS*. Cheltenham: Thomas Nelson and Sons Ltd.
- AVISON, J. (1989). *The world of PHYSICS*. Cheltenham: Thomas Nelson and Sons Ltd.
- BIPM. (2006). *The International System of Units (SI)*. (8 ed.). Sevres, France: International Bureau of Weights and Measures.
- Breithaupt, J. (2000). *Understanding Physics For Advanced Level*. (4 ed.). Ellenborough House, Italy: Stanley Thorners.
- Chand, S., & S.N., G. S. (2003). *Atomic Physics (Modern Physics)* (1 ed.). India.
- CPMD. (2015). *Advanced Level Physics Syllabus*. Kigali: REB.
- Cunningham, & William, P. (2000). *Environmental science* (6 ed.). Mc Graw-Hill.
- Cutnell, J. D., & Johnson, K. W. (2006). *Essentials of Physics*. USA: John Wiley & Sons, Inc.
- Cutnell, J. D., & Johnson, K. W. (2007). *Physics*. (7 ed.). USA: John Wiley; Sons, Inc.
- Cuttnell, J. D., & kennety, W. J. (2007). *Physics* (7 ed.). United State of America: John Willey & Sons . Inc.
- Douglass, C. G. (2014). *PHYSICS, Principles with applications*. (7 ed.). Pearson Education.
- Douglass, C. G. (2014). *PHYSICS, Principles with applications*. (8 ed.). Pearson Education.
- Duncan, T., & Kennett, H. (2000). *Advanced Physics* (5 ed.). London, UK: Holder Education.
- Giancoli, D. (2005). *PHYSICS: Principles with applications*. New Jersey: Pearson Education, Inc.
- Giancoli, D. C. (2005). *Physics principals with application*. Upper Saddle River, NJ 07458: Pearson Education, Inc.

Giancoli, D. C. (2005). *Physics: principals with application*. Upper Saddle River, NJ 07458: Pearson Education, Inc.

Giancoli, D. C. (2005). *Physics: Principles with applications*. New Jersey: Pearson Education, Inc.

Glencoe. (2005). *Physics - Principles and Problems [textbook]*. McGraw.

Haber-Schaim, U., Cutting, R., Kirkesey, H. G., & Pratt, H. A. (2002). *Force, Motion, and Energy*. USA: Science Curriculum, Inc.

Halliday, D., Resneck, R., & Walker, J. (2014). *Fundamentals of Physics*. (10 ed.). USA: John Wiley; Sons, Inc.

Halliday, Resneck, & Walker. (2007). *Fundamentals of Physics*. (8 ed.). Wiley.

Hewitt, P. G., SUCHOCKI, J., & Hewitt, L. A. (1999). *Conceptual Physical Science*. (2 ed.). Addison Wesley Longman.

Hirsch, A. S. (2002). *Nelson Physics 12*. Toronto: University Preparation.

Hugh, D. Y., & Roger, A. F. (2012). *University Physics with Modern Physics* (13 ed.). San Francisco, USA: Pearson Education, Inc.

IPCC. (1996). *Economics of Greenhouse Gas limitation, Main report "Methodological Guidelines"*.

John, M. (2009). *Optical Fiber Communications, Principals and Practice (3rd Ed.)*. London: Pearsnon Prentice Hall.

Jones, E. R., & Childers, R. L. (1992). *Contemporary College Physics*. (2 ed.). USA: Addison-Wesley Publishing Company.

Kansiime, J. K. (2004). *Coumpound Physical Geography: Morphology, Climatology, Soils and Vegetation*. uganda.

Linda, W. (2004). *Earth Sceience demystified a self-teaching guide*. USA: McGraw-Hill Campanies, inc.

Michael, E. B. (1999). *Schaum's outline of Theory and Problems of Physics for Engineering and Science*. USA: McGRAW-HILL Companies, Inc.

Michael, J. P., Loannis, M., & Martha, C. (2006). *Science Explorer, Florida Comprehensive Science*. Boston: Pearson Prentice Hall.

MIDIMAR. (2012). *Disaster High Risk Zones on Floods and Landslide*. Kigali: MIDMAR.

Nagashima, Y. (2013). *Elementary Particle Physics*. Osaka University: Deutsche

Nationalbibliothek.

Nelkon, M., & Parker, P. (1997). *Advanced level Physics*. (7 ed.). Edinburgh: Heinemann.

Nelkon, M., & Parker, P. (2001). *Advanced Level Physics* (7 ed.). Edinburgh gate: Heinemann.

Office, U. M. (2011). *Warming: A guide to climate change*. U.K.: Met Office Hadley Centre.

Orazio, S. (2010). *Principles of Lasers* (5 ed.). Milan, Italy: Springer.

Patrick, T. (2004). *Mathematics standard level*. (3 ed.). Victoria: Ibid Press.

R.B., B. (1984). *Physical Geography in diagrams for Africa*. Malaysia: Longmann Group Limited.

Randall, D., & Knight. (2004). *Physics for scientists and engineers: Stegic approach* (Vol. 2). San Fransisco: Pearson Education.

Randall, D., & Knight. (2004). *Physics for scientists and engineers: Stegic approach*. (Vol. 3). San Fransisco: Pearson Education, Inc.

Randall, D., & Knight. (2008). *Physics for scientists and engineers: Stegic approach*. (2 ed., Vol. 3). San Fransisco: Pearson Education, Inc.

Randall, D., & Knight. (2008). *Physics for scientists and engineers: Stegic approach*. (2 ed., Vol. 3). San Fransisco: Pearson Education, Inc.

REMA. (n.d.). *Rwanda Second National Communication Under the UNFCCC*. KIGALI: MINISTRY OF NATURAL RESOURCES,RWANDA.

Science, G. (2006). *Florida Physical Science with Earth Science*. USA: Mc Graw Hill Glencoe Companies, Inc.

Serway, R. A. (1986). *Physics for Scientists and Engineers* (2 ed.). Saunders College Publishing.

Serway, R. A. (1992). *Principles of Physics*. Orlando, Florida: Saunders College Publishing.

Serway, R. A., & Jewett, J. J. (2008). *Physics for Scientists and Engineers*. (7 ed.). USA: Thomson Learning, Inc.

Serway, R. A., & Jewett, J. J. (2010). *Physics for Scientists and Engineers with Modern Physics*. (8 ed.).

Silver, B., & Ginn, I. (1990). *Physical Science*. Unit States of America.

Stephen, P., & Whitehead, P. (1996). *Physics*. (2 ed.). School Edition.

Stephen, P., & Whitehead, P. (1996). *Physics*. (2 ed.). School Edition.

Strassler, M. (2011, September 25). *What's a Proton, Anyway?* Retrieved March 05, 2018, from [www.profmattstrassler.com](https://profmattstrassler.com/articles-and-posts/largehadroncolliderfaq/whats-a-proton-anyway/): <https://profmattstrassler.com/articles-and-posts/largehadroncolliderfaq/whats-a-proton-anyway/>

Subranya, K. (1993). *Theory and applications of fluid mechanics*. Tata McGraw: Hill Companies.

Taylor, E., & Wheeler, J. A. (1992). *Spacetime Physics: Introduction to Special Relativity*. (2 ed.). San Francisco: W.H.Freeman & Company, Publishers.

Taylor, E., & Wheeler, J. A. (1992). *Spacetime Physics: Introduction to Special Relativity*. (2 ed.). San Francisco: W.H.Freeman & Company, Publishers.

Tipler, P. A. (1991). *Physics for Scientists and Engineers*. (3 ed., Vol. 2). USA: Worth Publishers, Inc.

Tipler, P. A. (1991). *Physics for Scientists and Engineers*. (3 ed., Vol. 1). USA: Worth Publishers, Inc.

Tom, D. (2000). *Advanced Physics* (5 ed.). H. Kennett.

Toyol, D. C. (2008). *Nuclear Physics* (5 ed.). Himalaya Publishing House.

Uichiro, M. (2001). *Introduction to the electron theory of metals*. Cambridge University Press .

Weseda, Y., Mastubara, E., & Shinoda, K. (2011). *X-rays properties-google search*. Retrieved 03 06, 2018, from [www.springer.com](http://www.springer.com): <http://www.springer.com/978-3-642-26634-1>

Wysession, M., Frank, D., & Yancopoulos, S. (2004). *Physical Science*. Boston, Massachusetts, Upper Saddle River, New Jersey: Pearson Prentice Hall.